

**ESTES  
EDUCATOR™**

**INDUSTRIAL TECHNOLOGY  
AND  
MODEL ROCKETS**  
A Curriculum for  
Grades 6-12

A Teacher Guide developed by  
Richard Kalk, Ed. D. & Steve Wash

Edited by Ann Grimm



© 1995, 1999 Centuri Corporation.  
All rights reserved.

# Table of Contents

A. Introduction .....	4
B. Goals .....	4
C. Student Outcomes.....	4
D. General Background for the Teacher.....	8
E. Lesson Plans	
Section 1: Introduction to Spaceflight	
Activity 1: History of the Space Transportation System .....	14
Activity 2: History of Model Rockets.....	15
Section 2: Research	
Activity 1: Aerodynamic Forces .....	16
Activity 2: Design Considerations for Fins.....	17
Activity 3: Design Considerations for Nose Cones.....	19
Activity 4: Center of Pressure and Center of Gravity .....	21
Activity 5: Wind Tunnel Testing and Data Analysis.....	23
Section 3: Payload and Recovery	
Activity 1: Transportation .....	25
Activity 2: Payloads for Model Rockets .....	26
Activity 3: Research and Test Various Recovery Designs.....	28
Activity 4: Develop a Glider Recovery System.....	30
Section 4: Model Construction	
Activity 1: Constructing a Model from a Kit .....	31
Activity 2: Construct Several Prototypes and Select the Best One.....	33
Activity 3: Manufacturing Applications of Model Rocketry.....	34
Section 5: Design and Engineering	
Activity 1: Designing .....	36
Activity 2: Materials List.....	38
Activity 3: Computer Animation .....	40

Section 6: Dynamic Testing	
Activity 1: Preparing to Launch .....	43
Activity 2: Flight Mission Teams .....	44
Activity 3: Tracking.....	46
Section 7: Propulsion	
Activity 1: Rocket Engine Characteristics.....	49
Activity 2: Engine Selection .....	51
Activity 3: Static Engine Testing .....	52
Activity 4: Testing and Analysis Performance of Model Rocket Engines .....	55
Activity 5: Maximizing Model Rocket Performance.....	57
Section 8: Electronics	
Activity 1: Launch Equipment Circuitry.....	59
Activity 2: Designing a Multiple Rocket Launch Console .....	61
Section 9: Communications Applications	
Activity 1: Mission Logo.....	63
Activity 2: Press Kit.....	64
Activity 3: Newsletter .....	67
Activity 4: Launch/Recovery Credentials.....	68
Activity 5: Space Link .....	70
Activity 6: Technical Report .....	75
Activity 7: Aerial Photography .....	77

F. Launch Logs

G. Overhead Transparencies

H. Appendix

# Introduction

More than 30 years have passed since man first set foot on the moon. The “space race” that had such dynamic beginnings in the mid 1950’s has seemingly taken a back seat to newer technologies. As teachers of technology, we have an opportunity to generate an excitement in students that is unequalled by any other discipline.

This guide has been designed to give the Technology Education teacher a selection of materials that can be chosen to meet particular grade, maturity and interest levels. It is not intended to be a curriculum that is complete or sequential, for if it were, then the dynamics that create technology would cease to exist as technology is ever-changing.

This guide was developed to excite both the teacher and student. It includes far more suggestions than it is possible to use in a course. We assume (and we do this lightly) that the teacher will use this guide as supplementary materials to an already existing, more comprehensive Technology Education curriculum guide. Three of the four major clusters of Technology Education, as defined by the original Jackson’s Mill Project, communication, manufacturing and transportation, have been addressed in this guide. Activities may be excerpted to create your own curriculum, such as in the development of a Model Rocket/Space Transportation Technology module. The way that this guide is used is left up to the teacher.

We suggest that you develop a space/rocket resource center that contains software, videos, written briefs, etc. that are available through Estes, NASA, NAR, ITEA, U.S. Space Foundation, NSTA, and other space/rocket related organizations. Using your State Technology Association, you should be able to locate Technology Teachers who have participated in the NASA NEWMAS/NEWEST programs that are cosponsored by ITEA and NSTA to use as a resource. You may use the activities that we have included here as activities for your TSA chapter.

We have included some resource materials in the appendix, worksheets for many of the activities (Launch Logs) and overhead transparency masters. Estes resource materials that are referenced, but not included in this curriculum are “Laws of Motion”, “Model Rocket Launch Systems”, TR-1 & TR-3, TR-11, TN-4, TN-6 and video tape “Ignite the Imagination™”.

You are responsible for implementing the ideas that we have put forth in this guide under the safety guidelines and regulations of your Technology Laboratory. Above all, be sure that your students follow the Model Rocket Safety Code when working with the model rockets and model rocket engines.

We wish to thank Dr. Verner Burkett for his advice and encouragement during the developmental stages of this guide.

## GOALS

- Incorporate the various dynamics of technology into the study of model rocketry.
- Integrate technology with other disciplines such as math, science, history and English.

## STUDENT OUTCOMES

### Introduction to Spaceflight

- Identify the important milestones of space transportation.
- Identify individuals important to the beginning of space transportation.
- Identify the contributions of significant individuals during the early stages of the space age.
- Trace the development of model rocketry.
- Explain the significance that model rocketry played in the early stages of the development of space transportation systems.

### Research

- Identify the four forces that act on a rocket in flight.
- Describe Newton’s three laws of motion and how they relate to model rocketry.
- Identify the primary purpose of fins.

- Sketch and identify the various types of fins used by rockets.
- Demonstrate shaping techniques used to reduce fin drag.
- Identify the primary purpose of nose cones.
- Sketch various shapes of nose cones used by rockets.
- Demonstrate shaping techniques used to reduce nose cone drag.
- Explain the difference between pressure drag and friction drag.
- Use the cutout method to determine the lateral center of pressure (CP) of a rocket.
- Use string test to determine the center of gravity (CG) of a rocket.
- Determine the CG/CP relationship to predict the flight stability of a model rocket.
- Modify CG and predict its effect on flight stability.
- Build several model rockets incorporating various fin and nose cone designs.
- Use a wind tunnel to determine the efficiency of various fins and nose cones.
- Use a computer and Estes Astrocad™ software to estimate the drag of the various models.

### **Payload and Recovery**

- Explain the importance of space transportation systems as used for transportation.
- Identify different payloads that need to be transported by NASA and other space transportation agencies.
- Design samples of objects that need to be transported through space.
- Build models of objects that need to be transported through space.
- Determine the effects of payload on altitude.
- Determine the effects of payload on CP and CG.
- Identify and evaluate the six main types of recovery systems used by model rockets.
- Design and evaluate various parachute designs.
- Identify the different recovery systems used by the space shuttle.
- Identify the advantages of using a glider recovery system.
- Build and launch a piggy-backed parasite glider.

### **Design and Engineering**

- Use standard mechanical or CAD drawing principles to develop detail drawings for a completed model rocket kit.
- Use standard mechanical or CAD drawing techniques to develop detailed drawings of existing kit parts.
- Use standard mechanical or CAD drawing principles to develop an assembly drawing for a selected model rocket kit.
- Use standard mechanical or CAD drawing principles to develop a detailed cutaway drawing of a standard model rocket engine.
- Use standard 3D CAD principles to develop a 3D drawing of a model rocket kit.
- Generate a bill of materials for a model rocket kit.
- Estimate the cost of materials for a given number of model rockets.
- Develop a series of animation cels that follows a model rocket through the launch preparation flow.
- Develop a series of animation cels that explains model rocket safety.
- Develop a series of animation cels that follows a model rocket through the launch sequence.
- Develop a series of animation cels that shows a model rocket engine firing sequence.
- Develop a series of animation cels that follows a model rocket through the flight and recovery sequences.

## **Model Construction**

- Identify the different materials used to construct a model rocket.
- Identify the various parts of a model rocket and their functions.
- Demonstrate safe use of tools and materials during the construction of model rocket.
- Utilize workmanship and finishing techniques that will enhance the rockets performance.
- Use the Designer's Special™ kit to build several different model rockets.
- Determine the criteria to be used in evaluating the various models.
- Evaluate the various models to determine the best design.
- Select name for the new rocket design.
- Develop a complete set of instructions and parts list necessary to construct a model rocket kit.
- Design package for the new rocket design.
- Develop a flowchart to be used during the packaging of a model rocket kit.
- Setup an assembly line for the packaging of the new model rocket kit.

## **Dynamic Testing**

- Demonstrate NAR Model Rocketry Safety Code and complete a Flight Readiness Review (FRR).
- Analyze weather conditions and determine suitability for launch.
- Identify the conditions requiring FAA clearance and obtain clearance if necessary.
- Identify the various teams established by NASA to insure a successful mission.
- Determine the teams necessary for the completion of a successful mission of a model rocket.
- Identify the responsibilities and develop a checklist and flight data chart for each of these teams.
- Demonstrate tracking using single station or multi-station methods.
- Determine the altitude of a rocket based on calculations made from data collected during flight.
- Graphically determine the altitude reached by a model rocket.

## **Communications Applications**

- Make thumbnail sketches of mission logo/patch ideas.
- Make rough sketches of mission logo/patch ideas.
- Develop a final layout of the mission logo/patch.
- Print the mission logo/patch.
- Create a data base of local press.
- Write a press kit that describes your model rocket project.
- Contact the local press and invite them to your model rocket event.
- Follow-up press visits with a letter of appreciation.
- Write newspaper articles to describe your model rocket activities.
- Generate a newsletter that includes a banner, graphics and stories related to your classes model rocketry activities.
- Distribute the newsletter to other students in the school.
- Develop a criterion for launch security credentials.
- Develop a list of individuals who will need launch and recovery site clearance.
- Create launch security credentials.
- Laminate the launch security credentials.
- Establish and maintain a launch security team.
- Describe the benefits of Space Link.
- Log on to Space Link.
- Research space history on Space Link.
- Research a present or upcoming mission on Space Link.

- Develop a list of possible topics for a technical report.
- Choose a topic for a technical report.
- Write a technical report on the topic chosen.
- Construct and launch an Astrocams® 110.
- Use basic photo interpretation techniques to calculate the altitude of a rocket.
- Use basic photo interpretation techniques to determine the size of various objects on the ground.
- Make a map of an area photographed using the Astrocams® 110.
- Use the Astrocams® 110 to simulate a military reconnaissance mission.

### **Electronics**

- Draw a schematic of a standard electrical launcher.
- Draw a pictorial of a standard electrical launcher.
- Assemble a standard electrical launcher.
- Test a standard electrical launcher.
- Draw a schematic of a multiple electrical launch console.
- Generate a parts list for a multiple electrical launch console.
- Develop a cost estimate for a multiple electrical launch console.
- Assemble a multiple electrical launch console.
- Test a multiple electrical launch console.

### **Propulsion**

- Identify various model rocket engines' characteristics by their engine coding designations.
- Explain model rocket engine's fundamental functions.
- Identify model rocket engine sections.
- Explain the purpose of the centerbore on a model rocket engine.
- Explain the purpose of the delay and tracking charges on a model rocket engine.
- Explain the important considerations in selecting a model rocket engine.
- Interpret the model rocket engine selection chart.
- Choose an appropriate model rocket engine for a specific model rocket.
- Safely test various model rocket engines using a model rocket engine test stand.
- Gather the data from the static test of the model rocket engines.
- Analyze the data from the static test of the model rocket engines.
- Select different model rocket engines that can be safely used to fly a specified model rocket.
- Launch and recover a model rocket using various model rocket engines.
- Gather performance data on the launches of various model rocket engines.
- Analyze the data on the launches of various model rocket engines.
- Safely set up a model rocket engine for launch.
- Prepare and test model rocket launch equipment.

## **SCIENCE PROCESS SKILLS**

---

- |                   |                                   |
|-------------------|-----------------------------------|
| • Observing       | • Reading and following a diagram |
| • Analysis        | • Predicting                      |
| • Describing      | • Evaluating                      |
| • Problem Solving | • Identifying                     |

# GENERAL BACKGROUND FOR THE TEACHER

## A BRIEF HISTORY OF ROCKETRY (Courtesy of NASA Spacelink)

The earliest solid rocket fuel was a form of gunpowder, and the earliest recorded mention of gunpowder comes from China late in the third century before Christ. Bamboo tubes filled with saltpeter, sulphur and charcoal were tossed into ceremonial fires during religious festivals in hopes the noise of the explosion would frighten evil spirits.

It's probable that more than a few of these bamboo tubes were imperfectly sealed and, instead of bursting with an explosion, simply went skittering out of the fire, propelled by the rapidly burning gunpowder. Some clever observer whose name is lost to history may have then begun experiments to deliberately produce the same effect as the bamboo tubes which leaked fire.

Certainly by the year 1045 A.D. — 21 years before William the Conqueror would land on the shores of England — the use of gunpowder and rockets formed an integral aspect of Chinese military tactics.

A point of confusion arises tracing the history of rocketry back before 1045. Chinese documents record the use of “fire arrows,” a term which can mean either rockets or an arrow carrying a flammable substance.

By the beginning of the 13th Century, the Chinese Sung Dynasty, under pressure from growing Mongolian hordes, found itself forced to rely more and more on technology to counter the threat. Chinese ordnance experts introduced and perfected many types of projectiles, including explosive grenades and cannon.

Rocket fire-arrows were certainly used to repel Mongol invaders at the battle of Kai-fung-fu in 1232 A.D.

The rockets were huge and apparently quite powerful. According to a report: “When the rocket was lit, it made a noise that resembled thunder that could be heard for five leagues — about 15 miles. When it fell to Earth, the point of impact was devastated for 2,000 feet in all directions.” Apparently these large military rockets carried incendiary material and iron shrapnel. These rockets may have included the first combustion chamber, for sources describe the design as incorporating an “iron pot” to contain and direct the thrust of the gunpowder propellant.

The rocket seems to have arrived in Europe around 1241 A.D. Contemporary accounts describe rocket-like weapons being used by the Mongols against Magyar forces at the battle of Sejo which preceded their capture of Buda (now known as Budapest) Dec. 25, 1241.

Accounts also describe Mongol's use of a noxious smoke screen — possibly the first instance of chemical warfare.

Rockets appear in Arab literature in 1258 A.D., describing Mongol invaders' use of them on February 15 to capture the city of Baghdad.

Quick to learn, the Arabs adopted the rocket into their own arms inventory and during the Seventh Crusade used them against the French Army of King Louis IX in 1268.

It is certain that, not later than the year 1300, rockets had found their way into European arsenals, reaching Italy by the year 1500, Germany shortly afterwards, and later, England. A 1647 study of the “Art of Gunnery” published in London contains a 43-page segment on rockets. The Italians are credited, by the way, with adopting military rockets for use as fireworks — completing the circle, so to speak, of the bursting bamboo used at the Chinese festivals 1,700 years earlier.

The French Army traditionally has been among the largest, if not THE largest, army in Europe and was quick to adopt rockets to military operations. Records from 1429 show rockets in use at the siege of Orleans during the Hundred Years War against the English.

Dutch military rockets appear by 1650 and the Germans' first military rocket experiments began in 1668. By 1730, a German field artillery colonel, Christoph Fredrich von Geissler, was manufacturing rockets weighing 55 to 120 pounds.

As the 18th Century dawned, European military experts began to take a serious interest in rockets — if only because they, like the Magyars 500 years earlier, found themselves on the receiving end of rocket warfare.

Both the French and the British, during the Eighteenth Century, began wrestling for control of the riches of India. In addition to fighting one another, they also found themselves frequently engaged against the Mogol forces of Tippoo Sultan of Mysore. During the two battles of Seringapatam in 1792 and 1799, rockets were used against the British. One of Tippoo Sultan's rockets is now displayed in the Royal



Ordnance Museum at Woolwich Arsenal, near London.

Tippoo Sultan's father, Hyder Ally, had incorporated a 1,200 man contingent of rocketeers into his army in the year 1788. Tippoo Sultan increased this force to about 5,000 men, about a seventh of his total Army's strength.

Profiting from their Indian experience, the British, led by Sir William Congrieve (KON-greeve), began development of a series of barrage rockets ranging in weight from 300 to 18 pounds. Congrieve-design rockets were used against Napoleon.

It is surprising that Napoleon seems to have made no use of rockets in the French Army but it must be remembered Napoleon was an artillery officer and may have simply been too hide-bound a traditionalist to favor new-fangled rockets over more familiar cannons.

The scope of the British use of the Congrieve rocket can be ascertained from the the 1807 attack on Copenhagen. The Danes were subjected to a barrage of 25,000 rockets which burnt many houses and warehouses.

An official rocket brigade was created in the British Army in 1818.

Rockets came to the New World during the War of 1812.

During the Battle of Bladensburg, August 24, 1814, the British 85th Light Infantry used rockets against an American rifle battalion commanded by U.S. Attorney General William Pickney. British Lieutenant George R. Gleig witnessed the Americans' response to the new threat — "Never did men with arms in their hands make better use of their legs," he wrote.

On December 4, 1846, a brigade of rocketeers was authorized to accompany Maj. Gen. Winfield Scott's expedition against Mexico. The Army's first battalion of rocketeers — consisting of about 150 men and armed with about 50 rockets — was placed under the command of First Lieutenant George H. Talcott.

The rocket battery was used March 24, 1847 against Mexican forces at the siege of Veracruz.

On April 8 the rocketeers moved inland, being placed in their firing position by Captain Robert E. Lee (later to command the Confederate Army of Northern Virginia in the War Between the States). About 30 rockets were fired during the battle for Telegraph Hill. Later, the rockets were used in the capture of the fortress of Chapultepec, which forced the surrender of Mexico City.

With typical foresight, as soon as the fighting in Mexico was over, the rocketeer battalion was disbanded and the remaining rockets were placed in storage.

They remained in mothballs for about 13 years — until 1861 when they were hauled out for use in the Civil War. The rockets were found to have deteriorated, however, so new ones were made.

The first recorded use of rockets in the Civil War came on July 3, 1862, when Maj. Gen. J.E.B. Stuart's Confederate cavalry fired rockets at Maj. Gen. George B. McClellan's Union troops at Harrison's Landing, Va. No record exists of the Northerners' opinion of this premature "Fourth of July" fireworks demonstration.

Later in 1862, an attempt was made by the Union Army's New York Rocket Battalion — 160 men under the command of British-born Major Thomas W. Lion — to use rockets against Confederates defending Richmond and Yorktown, Virginia. It wasn't an overwhelming success. When ignited, the rockets skittered wildly across the ground, passing between the legs of a number of mules. One detonated harmlessly under a mule, lifting the animal several feet off the ground and precipitating its immediate desertion to the Confederate Army.

The only other documented use of rockets is at Charleston, S.C., in 1864. Union troops under Maj. Gen. Alexander Schimmelfennig found rockets "especially practical in driving off Confederate picket boats, especially at night."

As an interesting sidelight, the author Burke Davis, in his book "Our Incredible Civil War," tells a tale of a Confederate attempt to fire a ballistic missile at Washington, D.C. from a point outside Richmond, Va.

According to the author, Jefferson Davis witnessed the event at which a 12-foot-long, solid-fueled rocket, carrying a 10-pound gunpowder warhead in a brass case engraved with the letters C.S.A., was ignited and seen to roar rapidly up and out of sight. No one ever saw the rocket land. It's interesting to speculate whether, almost 100 years before Sputnik, a satellite marked with the initials of the Confederate States of America might have been launched into orbit.

The military appears to have remained underwhelmed with the potential of rockets. They were employed

in fits and starts in many of the brushfire wars which punctuated the otherwise calm closing days of the late Victorian Era. If the military was luke warm to rockets, another profession welcomed them with open arms.

The international whaling industry developed rocket-powered, explosive-tipped harpoons which were most effective against the ocean-going leviathans.

During the First World War, rockets were first fired from aircraft attempting to shoot down enemy hydrogen gas-filled observation balloons. Successes were rare and pilots resisted being asked to fire rockets from the highly flammable, cloth and varnish covered wings of their biplanes. The French were the principal users of aerial rockets, using a model developed by a Naval lieutenant, Y.P.G. LePrieur.

The principal drawback to rockets throughout this period of development was the type of fuel. Both here and abroad, experiments were under way to develop a more powerful, liquid-propelled rocket. Two young men stand out in this effort — one an American, Robert H. Goddard — the other a German, Wernher von Braun.

Radio commentator Paul Harvey tells a story of how young von Braun's interest in rocketry almost got him labeled as a juvenile delinquent. At the age of 13, von Braun exhibited an interest in explosives and fireworks. His father could not understand his son's consuming interest in so dangerous a hobby. He feared his son would become a safecracker. One day the young teenager obtained six skyrockets, strapped them to a toy red wagon and set them off. Streaming flames and a long trail of smoke, the wagon roared five blocks into the center of the von Braun family's home town, where they finally exploded.

As the smoke cleared, the toy wagon emerged as a charred wreck. Young von Braun emerged in the firm grasp of a policeman. Despite being severely reprimanded by his father, the youngster's interest would not be denied. By the age of 22 he had earned his doctorate in physics. Two years later he was directing Germany's military rocket development program.

Von Braun and his colleagues produced a number of experimental designs, the most famous of which was the A-4 rocket, which has gained distinction in history under another name — the vengeance weapon number two — V-2 for short. The V-2 was the first successful, long range ballistic missile, and von Braun is credited as its principal developer.

As World War II drew to a close, von Braun led his contingent of several hundred rocket scientists and engineers — all marked for death by the Nazis to prevent their capture by the Allies — into American lines.

In 1946, von Braun and his team arrived at White Sands, N.M., where, for the first time, von Braun learned of work done by the American rocket pioneer Robert Goddard.

Goddard's interest in rockets began in 1898 when, as a 16-year-old, he read the latest publication of that early science fiction writer, English novelist H.G. Wells. The book which so excited Goddard was later made into a 1938 radio program that nearly panicked our entire nation when it was broadcast. Orson Well's too realistic rendition of the "War of the Worlds" still causes many to shudder.

As the 20th Century began — Wilbur and Orville Wright were preparing to become the first men to fly. Goddard, however, was already designing rockets to probe the upper atmosphere and delve into space. Half a world away — and unknown to Goddard — a Russian school teacher, Konstantin Tsiolkovsky was thinking along much the same lines. Both came to the conclusion independently that, if a rocket was going to do the things they dreamed of, it would have to be powered by liquid fuels. Solid fuels of the time simply didn't have sufficient power. Tsiolkovsky lacked Goddard's practicality. While Tsiolkovsky worked out many principles of astronautics and designed suitable rockets, he never built any. By contrast, Goddard was a technical man. He could and did build rockets. By the time he died in 1945, Goddard held 214 patents in rocketry — patents which still produce royalties for his estate.

Goddard began his experiments in rocketry while studying for his doctorate at Clark University in Worcester, Mass.

He first attracted attention in 1919 when he published a paper titled, "A Method of Reaching Extreme Altitudes." In his paper he outlined his ideas on rocketry and suggested, none too seriously, that a demonstration rocket should be flown to the Moon.

The general public ignored the scientific merit of the paper — latching instead onto Goddard's Moon rocket proposal. At the time, such an endeavor was absurd and most dismissed Goddard as a "crank."

The experience taught Goddard a hard lesson — one which caused him to shy away from future opportunities to publicize his work. Publicity was far from Goddard's mind on the morning of March 16, 1926. On that day, barely a year after Wernher von Braun's rocket wagon fiasco, Goddard launched a liquid-powered

rocket he had designed and built from a snow-covered field at his Aunt Effie Goddard's farm in Auburn, Mass. The rocket flew — 152 feet — about the same distance as the Wright Brothers' first manned flight — but it did fly! It was the first flight of a liquid-fueled rocket in history.

When Goddard was later approached by the American Interplanetary Society in 1930 to publicize his work, Goddard refused. The society, rebuffed and learning that no one in the United States aside from Goddard was working with rockets, turned its attention to rocket research under way in Europe, where rocketry was beginning to develop a following.

In the spring of 1931, two founder-members of the American society, husband and wife Edward and Lee Pendray, travelled on vacation to Germany where they made contact with the German Rocket Society, which had been formed in 1927. The visiting Americans were given a preview of the future when a member of the German Rocket Society — Prof. Willy Ley — took the pair to the Germans' rocket flying test ground in the suburbs of Berlin.

Returning home, the Pendrays filed an enthusiastic report of their visit, prompting the American society to build its first rocket. The attempted test flight in November 1932 ended with the American design firmly on the ground. It's unfortunate the Pendrays didn't meet another future rocketry hall-of-famer who also was a member of the German society.

Rumanian-born Hermann Oberth wrote, in 1923, a highly prophetic book: "The Rocket into Interplanetary Space." The book enthralled many with dreams of space flight, including that precocious German teenager, Wernher von Braun, who read the book in 1925. Five years later, von Braun had joined Oberth and was assisting with rocket experiments.

By 1932, the German Army was beginning to show an interest in the German Rocket Society's efforts. In July of that year, a "Mirak" rocket was launched as a demonstration for the head of the newly created German Army rocket research group, Captain (later Major General) Walter Dornberger.

Mirak didn't impress Dornberger. Von Braun did. Three months after the demonstration flight, von Braun was engaged to work on liquid propelled rockets for the Army. Most of the German Rocket Society followed von Braun into national service and the society disbanded.

By December 1934, von Braun scored his first successes with an A2 rocket powered by ethanol and liquid oxygen. Two years later, as plans for the follow-on A3 rocket were being finalized, initial planning began for the A4 rocket — a rocket that was to be, in Dornberger's words, a practical weapon, not a research tool. As noted earlier, most know the A4 by another name — the V-2.

The rocket researchers quickly outgrew their facilities at Kummersdorf on the outskirts of Berlin. In 1936, operations were transferred to a remote island on Germany's Baltic coast — Peenemuende.

Between 1937 and 1941, von Braun's group launched some 70 A3 and A5 rockets, each testing components for use in the proposed A4 rocket.

The first A4 rocket flew in March 1942. The rocket barely cleared some low clouds before crashing into the sea a half mile from the launch site.

The second launch in August 1942 saw the A4 rise to an altitude of 7 miles before exploding.

The third try was the charm. On October 3, 1942, another A4 roared aloft from Peenemuende, followed its programmed trajectory perfectly, and landed on target 120 miles away. This launch can fairly be said to mark the beginning of the space age. The A4, the first successful ballistic rocket, is the ancestor of practically every rocket flown in the world today.

Production of the A4 began in 1943 and the first A4s, now renamed V2s, were launched against London in September 1944.

The V-2 offensive came too late to affect the course of the war. By April 1945, the German Army was in full retreat everywhere and Hitler had committed suicide in his bunker in Berlin.

At an inn near Oberjoch, the Haus Ingeburg, von Braun and over 100 of his rocket experts waited for the end. The entire team had been ordered executed by Hitler to prevent their capture. Wernher von Braun's brother Magnus, however, managed to contact nearby American forces before Hitler's SS henchmen could reach the rocket team. On May 2, the same day Berlin fell to the Soviet Army, von Braun and his rocket team entered American lines and safety.

With the fighting over, von Braun and his team were heavily interrogated and jealously protected from Russian agents. V2s and V2 components were assembled. German rocket technicians were rounded up. In

June, General Eisenhower sanctioned the final series of V2 launches in Europe. Watching each of the three V2s which rose from a launch site at Cuxhaven was a Russian Army colonel, Sergei Korolev. Ten years later, Korolev would be hailed as the Soviet Union's chief designer of spacecraft and the individual responsible for building the Vostok, Voshkod and Soyuz spacecraft which, since 1961, have carried all Soviet cosmonauts into orbit.

Few members of von Braun's team participated in the Cuxhaven launches. Most had already begun setting up shop at Fort Bliss, near El Paso, Texas. Piled up in the desert near Las Cruces, New Mexico, were enough parts to build 100 V2s. Von Braun and his team soon moved to nearby White Sands Proving Ground where work began assembling and launching V2s. By February 1946, von Braun's entire Peenemuende team had been reunited at White Sands and, on April 16, the first V2 was launched in the United States. The U.S. space program was under way! Up to 1952, 64 V2s were launched at White Sands. Instruments, not explosives, packed the missiles' nosecones. A V2 variant saw the missile become the first stage of a two stage rocket named Bumper. The top half was a WAC Corporal rocket. The need for more room to fire the rockets quickly became evident and, in 1949, the Joint Long Range Proving Ground was established at remote, deserted Cape Canaveral, Fla. On July 24, 1950, a two-stage Bumper rocket became the first of hundreds to be launched from "the Cape."

The transfer of launch operations to the Cape coincided with the transfer of the Army's missile program from White Sands to a post just outside a north Alabama cotton town called Huntsville. Von Braun and his team arrived in April 1950 — it was to remain his home for the next 20 years — 20 years in which the city's population increased ten fold.

The Von Braun team worked to develop what was essentially a super-V2 rocket, named for the U.S. Army arsenal where it was being designed — the Redstone.

In 1956, the Army Ballistic Missile Agency was established at Redstone Arsenal under von Braun's leadership to develop the Jupiter intermediate range ballistic missile. A version of the Redstone rocket, known as the Jupiter C, on January 31, 1958 was used to launch America's first satellite, Explorer I. Three years later, Mercury Redstones launched Alan Sheppard and Gus Grissom on suborbital space flights, paving the way for John Glenn's first orbital flight.

In 1958, NASA was established and two years later von Braun, his team and the entire Army Ballistic Missile Agency were transferred to NASA to become the nucleus of the agency's space program.

The Army Missile Command, which owns Redstone Arsenal, continued its vital national defense mission after the transfer of ABMA to NASA, chalking up a remarkable number of successful programs to augment America's landpower. MICOM's successes include the Pershing II, the NIKE weapons systems, the HAWK system, Improved HAWK, Corporal, Sergeant, Lance and Chaparral, to name a few.

Pursuing a separate course — that of developing rockets for space exploration — the Marshall Space Flight Center's past quarter century has been a time of superlatives.

In 1961, almost as Alan Sheppard was drying off from his landing in the Atlantic following his riding a Marshall-designed Redstone rocket on a sub-orbital flight which made him the first American in space, President Kennedy committed this nation to being first on the Moon. NASA's Marshall Center was charged with developing the family of giant rockets which would take us there.

The Saturn rockets developed at Marshall to support the Apollo program and to honor President Kennedy's pledge were, at the time, the most powerful space launch vehicles yet to have been invented.

Engineers, scientists, contractors and other support personnel built well. On July 20, 1969, a transmission from the Moon's Sea of Tranquility reported "the Eagle has landed."

Marshall's Saturn rockets first took us around the Moon, then to its cratered surface. Marshall-developed lunar excursion vehicles — the ungainly Moon Buggies — carried astronauts on far-ranging excursions in pursuit of samples of lunar soil and rock.

Closer to home, the team at Marshall developed America's first space station — Skylab. Built to replace the upper stage of a Saturn V moon rocket, the Skylab module was successfully placed in orbit early on May 14, 1973.

Placing Skylab in orbit marked a major transition in the story of rocketry. Up until Skylab, the rocket had been the star — the featured attraction. The focus had been on the up and down — launch and recovery. Skylab, in essence, stole the show. For the first time, space became a place in which to live and work. Flying aboard a rocket was about the Earthside equivalent of driving the family car to work. Just as having

to drive to work is only incidental to work itself — flying aboard a rocket became secondary to the work done once Skylab had been reached. The rocket, simply stated, became a means to an end — the end in this case being the opportunity to learn to live and work in space.

A rash of malfunctions plagued Skylab's early days — problems which tested the resourcefulness of the entire NASA team. The problems were overcome, however, and Skylab went on to become one of Marshall's proudest achievements.

A Marshall-developed Saturn I-B also carried aloft America's half of the first — and only — joint U.S.-Soviet space endeavor, the Apollo-Soyuz project.

After Apollo, the team at Marshall tackled designing a revolutionary national space transportation system, which came to be known simply as "The Space Shuttle."

It is anything but simple!

The space shuttle main engines are among the most powerful, most sophisticated devices ever invented. They represent a quantum leap in technology advancement over the engines which powered the Saturn V. Each of the three main engines in the tail of the shuttle can provide almost a half-million pounds of thrust, a thrust equal to that produced by all eight of the Saturn I's first stage engines. Unlike most previous rocket engines, which were designed to be used only once — and then for only a few minutes — the space shuttle's main engines are designed to be used again and again, for up to 7.5 hours. The thrust to weight ratio for these engines is the best in the world — each engine weighs less than 7,000 pounds but puts out the power equivalent of seven Hoover Dams!

Twenty-four successful flights of the space shuttle lulled America into a sense of complacency. Shuttle launches became routine — a ho-hum event which had to scramble for an inch or two on page 2.

Then came the Challenger disaster...

The time since the loss of Challenger has been the busiest in the history of Marshall Space Flight Center. Teams of experts have been organized to find and fix the problems which led to the accident. Investigation quickly focused on a defective joint in the space shuttle's solid rocket motors. Rocket propulsion experts devised a number of modifications to the solid rocket motor design to remedy the fault.

A vigorous test program is now under way to show the problems have been solved.

The disaster-enforced hiatus in shuttle operations has given Marshall — and other NASA installations — an opportunity to address other shuttle-related concerns. Major steps have been made at enhancing the reliability and safety of the turbine blades and turbo pumps in the shuttle's main engines. An escape system has been examined for the shuttle crew. Improvements have been made to the orbiter's landing gear and brakes.

When America returned to manned spaceflight, it did so in a space vehicle which is vastly safer and more capable.

NASA also is examining using expendable launch vehicles on missions which do not require the shuttle's unique capabilities, and is looking into development of a new generation of heavy lift launch vehicles.

These will become the next chapter in the story of rocketry — a story whose first chapters were written more than 2,400 years ago.

No one can say where our path will lead or when — hopefully never — the last chapter in this history will be written.

# SECTION 1

## INTRODUCTION TO SPACEFLIGHT

### **Activity 1 - History of the Space Transportation System**

---

#### **OBJECTIVES:**

By the end of this lesson, the student will be able to:

- Identify the important milestones of space transportation.
- Identify individuals important to the beginning of space transportation.
- Identify the contributions of significant individuals during the early stages of the space age.

#### **BACKGROUND FOR THE TEACHER:**

While the idea of space transportation systems originally developed through the bright eyes of science fiction writers, the ability to travel in space has been around for a very short period of time. Early in the 20th century, an American, Robert Goddard, conducted practical experiments with solid-fuel and liquid-fuel rockets. The world entered the space age on October 4, 1957 when the world was stunned by the news that the Soviet Union had launched an Earth-orbiting artificial satellite called Sputnik I. This news alarmed the United States and space exploration began in the United States when on January 31, 1958 the Army launched Explorer I. Later that year, the United States formally organized its space program by creating the National Aeronautics and Space Administration (NASA). What followed was a space race between the Soviet Union and the United States that reached a climax on July 20, 1969 when two American astronauts, Neil Armstrong and Buzz Aldrin, landed on the surface of the moon. Through the efforts of space transportation's pioneers, such as Goddard, Armstrong and Aldrin, the second half of this century has seen great strides in space transportation.

There is a wealth of information on the history of space transportation available through the NASA Centers and from Spacelink (see section 9.5 for instructions on how to access Spacelink).

#### **STRATEGY:**

##### **Materials needed for entire class:**

- A collection of books and articles on the history of space transportation (may be checked out from school or public library).

1. Initiate a class discussion on the history of space transportation.
2. After reviewing the various of books and articles on the history of space transportation, the class should develop a timeline of significant events in the history of space transportation.
3. Each student should select (or be assigned) an event from the class-developed timeline for which additional research should be completed.

#### **CLOSURE:**

After completing the research, each student should make a brief presentation on the specific event for which they were assigned.

#### **EVALUATION:**

Students should be evaluated based on the:

- Presentation of a significant event from the history of space transportation.

**EXTENSION:**

An advanced activity for this lesson might be the compiling of the information collected from the research into a computer data base.

**NOTES**

## SECTION 1

# INTRODUCTION TO SPACEFLIGHT

### **Activity 2 - History of Model Rockets**

---

**OBJECTIVES:**

By the end of this lesson, the student will be able to:

- Trace the development of model rocketry.
- Explain the significance that model rocketry played in the early stages of the development of space transportation systems.

**BACKGROUND FOR THE TEACHER:**

Early in the 20th century, an American, Robert Goddard, conducted practical experiments with small-scaled rockets. A pamphlet he published in 1919 entitled “A Method of Reaching Extreme Altitudes” was a mathematical analysis of what today is called the meteorological sounding rocket. Goddard learned much of what he knew about rocketry from launching and analyzing model rockets. Even today, models continue to serve as important tools for scientists.

**STRATEGY:**

**Materials needed for entire class:** Video tape “Ignite the Imagination™.”

1. Show the class the video tape entitled “Ignite the Imagination™.” This tape serves as an excellent introduction to the study of model rocketry.
2. Activity one of this guide should have produced a body of material concerning the early days of space exploration. Continue the discussion of early space exploration; however, it should focus not on what happened, but why the early pioneers did what they did.
3. Divide the class into teams and conduct a contest in which the teams earn points by providing an advantage to using a model in an experiment.

**CLOSURE:**

Have the class name other areas of experimentation that makes extensive use of models.

**NOTES**

# SECTION 2

## RESEARCH

### Activity 1 - Aerodynamic Forces

---

#### OBJECTIVES:

By the end of this lesson, the student should be able to:

- Identify the four forces that act on a rocket in flight.
- Describe Newton's three laws of motion and how they relate to model rocketry.

#### BACKGROUND FOR THE TEACHER:

There are four forces that act on all objects that travel through the air. These four forces are gravity, thrust, lift and drag. Information on Newton's Laws of Motion is available in the Estes "Newton's Laws of Motion and Model Rocketry."

#### VOCABULARY:

**Drag:** Frictional force or resistance between the surface of a moving object and air.

**Gravity:** Force that attempts to pull objects back to the surface of the earth.

**Lift:** An aerodynamic force created by airflow over the wings or fins of an aerospace vehicle.

**Thrust:** The forward-directed force of an airplane or rocket as a reaction to the rearward ejection of fuel gases at high velocities.

#### STRATEGY:

**Materials needed for each student:** Copy of "Newton's Laws of Motion and Model Rocketry"; Launch Log 2.1, "Laws of Motion."

**Materials needed for entire class:** Medicine ball, swing or office chair with casters.

**Motivation:** Using Overhead Transparency TR2.1A, discuss with the class the four forces that act on an object moving through the air. Drag is usually the hardest concept for students to understand. A good example of drag is the feeling of air against your hand as you place it out the open window of a moving automobile.

1. Distribute the copies of "Newton's Laws of Motion and Model Rocketry". As the students read about Newton's Laws of Motions, each student should complete Launch Log 2.1. After all students have completed the Launch Log, use overhead transparencies TR2.1B, TR2.1C and TR2.1D to discuss with the class Newton's 3 Laws of Motion.
2. Select several students of different weights to assist with demonstrating Newton's 3rd Law of Motion.
3. Depending on availability, either take the class outside to a swing or to an open area with a smooth floor and an office chair with casters.
4. Have one of the students sit in the swing (chair) and let it come to rest. With the medicine ball close the their chest, have the student throw the medicine ball across the school yard (room). This should cause the student to move in the opposite direction of the travel of the medicine ball.
5. Discuss with the class how this activity demonstrates Newton's 3rd law of motion.



6. Repeat this exercise with students of varying weight and strength. Discuss the results with the class.
7. If using an office chair, students may use 2 or more medicine balls to simulate multiple stages of a rocket. Students can accomplish this by holding the extra balls in their laps and throwing the extra ball(s) as momentum is lost.

**CLOSURE:**

Discuss the reasons some students moved greater distances when they threw the medicine ball.

**EVALUATION:**

Students should be evaluated based on the:

- Completion of Launch Log 2.1.
- Participation in the class discussion.

**EXTENSION:**

An additional activity for this lesson might be a contest in which teams develop and test balloon power vehicles.

**NOTES**

## **SECTION 2 RESEARCH**

### **Activity 2 - Design Considerations for Fins**

---

**OBJECTIVES:**

By the end of this lesson, the student will be able to:

- Identify the primary purpose of fins.
- Sketch and identify the various types of fins used by rockets.
- Demonstrate shaping techniques used to reduce fin drag.

**BACKGROUND FOR THE TEACHER:**

This lesson will help students understand the purpose of fins and the factors that contribute to their effectiveness. Although drag was introduced in section 2.1, this lesson will take a much closer look at this aerodynamic force. The teacher should review the information in TR-11 “Aerodynamic Drag of Model Rockets” in preparation for this lesson.

## VOCABULARY:

**Aerodynamics:** The study of the interaction between air and moving objects.

**Drag:** Frictional force or resistance between the surface of a moving object and air.

**Leading edge:** The front edge of the fin exposed to the greatest amount of air pressure build-up.

**Root edge:** The point at which a fin is attached to the body tube.

**Tip:** The outermost end of a fin.

**Trailing edge:** The rear edge of a fin.

## STRATEGY:

**Materials needed for each student:** Launch Log 2.2, hobby knife, sandpaper.

**Materials needed for entire class:** Materials from Estes Designer's Special™ kit, Overhead Transparencies TR2.2A, TR2.2B, TR2.2C, TR2.2D and TR2.2E.

**Motivation:** Students should be made aware that the fins that they will be shaping may be used for a competition in a later section of this guide.

1. The primary purpose of the fins is to serve as the rocket's guidance system. Model rocket fins are usually fixed; whereas some actual rockets employ fins that have movable components that allow for the in-flight control of the rocket's guidance. Initiate a class discussion of the guidance systems of other types of transportation.
2. Using Overhead Transparency TR2.2A, discuss the four most common shapes of fins; rectangular, elliptical, straight-tapered and swept-tapered. Distribute Launch Log 2.2 and have students provide a thumbnail sketch of a rocket for each of the four common fin shapes.
3. Use Overhead Transparency TR2.2B to define the parts of fin. Students should label the parts of a fin on Launch Log 2.2.
4. One of the major concerns when designing and constructing fins is the effects of drag. Use Overhead Transparency TR2.2C to help illustrate the effects of drag on a hand placed out the open window of a moving automobile. Because the palm of the hand has a greater surface area coming in contact with the moving air, it produces greater drag than the edge of the hand. Ask the students to give other common examples of drag.
5. The shape of the fin is one factor that determines the amount of drag produced. Fin characteristics such as the total surface area, total span and sweep angle all help to determine the amount of drag produced by a rocket's fins. Additionally, the sectional shape, as viewed from the fin's tip, is a great determiner of the amount of drag produced by a rocket's fins. Using Overhead Transparency 2.2D, discuss the effectiveness of the three sections shown.
6. Fin workmanship plays a large role in determining the drag produced by a rocket's fins. Show Overhead Transparency 2.2E and discuss the differences between the two examples.
7. Demonstrate to the class the safe method of cutting and shaping balsa fins.
8. Divide the class into teams of three. Each team should be assigned a fin shape and should produce three identical fins to be used in a later section.

## CLOSURE:

Each team should identify for the class the basic shape of their fins. Additionally, the team should describe the shaping techniques used to enhance the performance of the fins.

**EVALUATION:**

Students should be evaluated based on the:

- Completion of Launch Log 2.2
- Completed fins produced by each team.

**EXTENSION:**

An advanced activity for this lesson might be to have students determine the aspect ratio of various fin designs as described on page 16 & 17 of the Estes TR-11 “Aerodynamic Drag of Model Rockets.”

**NOTES****SECTION 2  
RESEARCH****Activity 3 - Design Considerations for Nose Cones**

---

**OBJECTIVES:**

By the end of this lesson, the student will be able to:

- Identify the primary purpose of nose cones.
- Sketch various shapes of nose cones used by rockets.
- Demonstrate shaping techniques used to reduce fin drag.
- Explain the difference between pressure drag and friction drag.

**BACKGROUND FOR THE TEACHER:**

The primary purpose of a nose cone on a model rocket is to streamline the rocket and reduce drag. Full-sized commercial and military rockets carry payloads, such as satellites and warheads, in their nose cones. In this activity, students will learn what factors effect drag when designing and shaping a nose cone. Additionally, students will shape various nose cones to be used in a later activity.

**VOCABULARY:**

**Friction drag:** The resistance between a fluid and the surface of a moving object.

**Nose Cone:** The foremost surface of a model rocket, generally tapered in shape to allow for streamlining, usually made of balsa or plastic.

**Pressure drag:** Retarding force determined by the shape of an object.

**STRATEGY:**

**Materials needed for each student:** Launch Log 2.3.

**Materials needed for each team:** Balsa nose cone or balsa block, sand paper, paint, paint brush.

**Materials needed for entire class:** Overhead Transparency TR2.3A, TR2.3B AND TR2.3C.

**Motivation:** Students should be made aware that the nose cones that they will be shaping may be used for a competition in a later section of this guide.

1. Ask the class what they believe to be the primary purpose of a nose cone on a model rocket. Is this the same for full-sized commercial or military rockets? The primary purpose of a nose cone on a model rocket is to streamline the rocket and reduce drag. Full-sized commercial and military rockets carry payloads, such as satellites and warheads, in their nose cones. Show the class Overhead Transparency TR2.3A and ask the students which nose cones they believe to be the most effective in reducing drag.
2. Use Overhead Transparency TR2.2C as a review of the basic concept of drag. Another way of changing the amount of drag in this example would be making a fist and comparing the drag produced with the amount of drag produced by the open hand.
3. On Overhead Transparency TR2.3B, there are two pictures of a baseball. In the first picture the ball is at rest and the atmospheric pressure is equal all around the ball. This balance of pressure results in no drag on the ball. However, in the second picture the ball is moving as result of being hit by a bat. There is a greater atmospheric pressure on the forward portion of the ball as compared to the rear portion. This imbalance of pressure is known as pressure drag. Pressure drag is determined in large part by the shape of an object.
4. Overhead Transparency TR2.3C illustrates a type of drag known as friction drag. This drag is the resistance between a fluid, such as air, and the surface of a moving object, such as a nose cone. Give each student a small sheet of sandpaper. The sandpaper will represent the surface of the nose cone. The student's hand will represent the air coming in contact with the moving nose cone. Ask each student to place the sandpaper flat on the desktop with rough surface face down. As they slowly slide their hands across the surface, ask them to describe what they feel. Repeat this procedure with the rough surface face up. Compare the two procedures. This is an example of friction drag.
5. Students should make three thumbnail sketches of nose cones on Launch Log 2.3. Additionally, each student should define drag, pressure drag and friction drag in their own words.
6. Divide the class into teams of 2 or 3 and supply each team with a balsa nose cone or balsa block. Each team should modify, sand and paint their nose cone to achieve the lowest pressure and friction drag possible.

#### **CLOSURE:**

Review the terms; drag, pressure drag and friction drag and the conditions effecting each of them.

#### **EVALUATION:**

Students should be evaluated based on the:

- Completion of Launch Log 2.3.
- Quality of the completed nose cones.

#### **EXTENSION:**

An additional activity for this lesson might be a contest in which students or teams of students compete to build the most aerodynamic rocket. The competition could be based on measuring altitude of flight or based on drag measured and compared using a wind tunnel. The teacher should set specifications for weight and size.

## NOTES

# SECTION 2 RESEARCH

## **Activity 4 - Center of Pressure and Center of Gravity**

---

### **OBJECTIVES:**

By the end of this lesson, the student will be able to:

- Use the cutout method to determine the lateral CP of a rocket.
- Use string test to determine the CG of a rocket.
- Determine the CG/CP relationship to predict the flight stability of a model rocket.
- Modify CG and predict its effect on flight stability.

### **BACKGROUND FOR THE TEACHER:**

If a rotating force is applied to a free body in space, it will cause it to rotate around its center of gravity. There are a number of rotating forces, such as lateral wind, that act on a rocket in flight; therefore, a rocket must be designed to overcome these forces. In short, the center of gravity must be ahead of the rocket's center of pressure.

### **VOCABULARY:**

**Center of Gravity:** The point in a rocket around which its weight is evenly balanced; the point at which a model rocket will balance on a knife edge. Abbreviation: CG. Icon: 

**Center of Pressure:** The center of all external aerodynamic forces on the completed rocket including the body, nose cone and fins. Abbreviation: CP. Icon: 

### **STRATEGY:**

**Materials needed for each student:** A copy of Technical Report TR-1 “Basic Rocket Stability” from the Estes “The Classic Collection”, Launch Log 2.4.

**Materials needed for each team:** Card stock or other heavy paper, 12” ruler, string, tape, scissors, 2 ounce lead weight.

**Materials needed for entire class:** Electric fan, heavy wire, 3”x3” cardboard, thumbtacks, 24” x 1/2” dowel, 5 or 6 rockets to be used to find center of gravity and center of pressure.

1. Distribute copies of Technical Report TR-1 “Basic Rocket Stability.” As the students read about basic rocket stability, each student should complete Launch Log 2.4. After all students have completed the Launch Log, the entire class should discuss the significance of center of gravity, center of pressure and the ways of determining each.
2. Demonstrate the dowel experiment in Technical Report TR-1 to the class and discuss the results. This should demonstrate the importance of fins as devices for guidance.

3. Divide the class into teams of 2 or 3 students per team. Provide each team with string, tape, scissors and card stock. Provide the class with 5 or 6 numbered rockets that can be used to find the center of gravity and the center of pressure.
4. Each team should make a cutout of each of the rockets and number the cutouts to match the actual rockets. Using the cutout method described in Technical Report TR-1, each team should determine the center of pressure for each of the rockets. Mark the center of pressure with a line and the letters CP. By balancing the actual rocket on the edge of a ruler, each team should determine the center of gravity for each rocket and mark its location on the corresponding cutout. Mark the center of gravity with a line and the letters CG. Record the results on Launch Log 2.4.
5. Demonstrate and alert the class of the following safety precaution before the swing test. To avoid collision with objects or persons nearby, caution should be exercised when swinging rockets overhead. Velocities in excess of 100 miles per hour are possible. This is sufficient to cause injury.
6. Using the swing method described in Technical Report TR-1, each team should determine the flight stability for each of the rockets. Record the results on Launch Log 2.4.
7. Secure a 2 ounce lead weight below the nose cone of each rocket by packing the tube with paper and replacing the nose cone. Repeat the tests for center of gravity and mark the new center of gravity with a line and the letters CG1. Repeat the tests for flight stability and record the results on Launch Log 2.4.

**CLOSURE:**

Reassemble the class and compare each team's results from the test for center of pressure, center of gravity and flight stability.

**EVALUATION:**

Students should be evaluated based on the:

- Completion of Launch Log 2.4.

**EXTENSION:**

An additional activity for this lesson might be to use a wind tunnel or electric fan to determine flight stability.

**NOTES**

# SECTION 2

## RESEARCH

### Activity 5 - Wind Tunnel Testing and Data Analysis

---

#### OBJECTIVES:

By the end of this lesson, the student will be able to:

- Build several model rockets incorporating various fin and nose cone designs.
- Use a wind tunnel to determine the efficiency of various fins and nose cones.
- Use a computer and Astrocad™ to estimate the drag of the various models (advanced activity).

#### BACKGROUND FOR THE TEACHER:

This activity uses a wind tunnel to collect data concerning the aerodynamics of various rocket designs. Because of the wide variety of wind tunnels on the market, the directions for this activity are fairly general. For the classrooms that do not have a wind tunnel, a suggested design for a teacher-made wind tunnel is contained in the appendix.

#### VOCABULARY:

**Wind tunnel:** A chamber through which air is forced at controllable velocities in order to study the aerodynamic flow around and effects on airfoils, scale models or other objects mounted within.

#### STRATEGY:

**Materials needed for each student:** Launch Log 2.5.

**Materials needed for each team:** The fins from Section 2.2 “Design Considerations for Fins” and the nose cone from Section 2.2 “Design Considerations for nose cones”, body tubes from the Estes Designer’s Special™ kit, glue.

**Materials needed for entire class:** Wind tunnel, Astrocad™ software, compatible computer, Estes Technical Report TR-11 “Aerodynamic Drag of Model Rockets.”

**Motivation:** The teams of students from activities 2.2 and 2.3 of this section will be assembling rockets to be tested for aerodynamic efficiency. The teacher may wish to stage a competition to recognize the best team of “aeronautic engineers.”

1. Demonstrate to class the method to be used for attaching fins to the body tube.
2. Divide the class into the same teams of 2 or 3 students per team from activities 2.2 and 2.3. Provide each team with that group’s fins from activity 2.2.
3. Following the instructions provided by the teacher, each team should attach their fins to a blank body tube from the Estes Designer’s Special™ kit. These rockets should be placed in safe place until the glue dries.
4. Each team should place their nose cone from activity 2.3 in another blank body tube and bring the assembly to the front of the class when instructed to do so by the teacher.
5. As the teacher assists with the testing of each team’s nose cone in the wind tunnel, the teacher may wish to assign a class recorder to collect data from the tests to determine the best nose cone design for the entire class. Additionally, each student should record the data concerning his/her team on Launch Log 2.5.

6. Once the glue dries on the body tube fin assemblies (this may be next day), each team should bring their rockets to the front of the class when instructed to do so by the teacher. With the teacher's assistance, each team should test its rocket assembly (body tube, fins and nose cone) in the wind tunnel. Record the results on Launch Log 2.5.
7. Replace the team's nose cone with the best design from the class and repeat the wind tunnel test. Record the results on Launch Log 2.5.

**CLOSURE:**

After comparing the results from all the tests, the class should select the best three designs to be completed and used in an advanced activity with Astrocad™.

**EVALUATION:**

Students should be evaluated based on the:

- Completion of Launch Log 2.5.
- Assembly and testing of the team's rocket.

**EXTENSION:**

An advanced activity for this lesson would be to use a computer and Astrocad™ to estimate the drag of the various models. The class will need to launch, track and collect data for several rockets and use Astrocad™ to estimate the rockets' drag.

**NOTES**



# SECTION 3

## PAYLOAD AND RECOVERY

### Activity 1 - Transportation

---

#### OBJECTIVES:

By the end of this activity, the student will be able to:

- Explain the importance of space transportation systems as used for transportation.
- Identify different payloads that need to be transported by NASA and other space transportation agencies.
- Design samples of objects that need to be transported through space.
- Build models of objects that need to be transported through space.

#### BACKGROUND FOR THE TEACHER:

The teacher may wish to assemble a collection of books and magazine articles on space transportation for this activity. Educational materials may also be obtained free or at a nominal costs from NASA (see appendix). Another option would be to plan a research trip to the school's media center. This activity's primary purpose is to make students aware of the different payloads that are launched into space.

#### STRATEGY:

**Materials needed:** Books and magazine articles on space transportation, Launch Log 3.1, materials to construct model payloads (cardboard, aluminum foil, Mylar, paper, monocoat and similar materials), #10 can.

**Motivation:** Initiate a brief class discussion of the different payloads that have been launched into space. The Hubble Space Telescope, Spacelab and communications satellites are examples of payloads that should be familiar to most students.

1. Based on the availability of resources, either make books and articles on space transportation available to the class or take the entire class to the school's media center to conduct research on payloads that have been launched into space. Dates of launch, size, weight, purpose and method of launch are types of information that should be included in research findings. Students should record information found during completion of research on Launch Log 3.1 "Rocket Payloads."
2. After returning from the media center, divide students into teams of 3 or 4 students per team. Teams should select a type of payload to be included on a future rocket launch and make thumbnail sketches of the payloads.
3. Each team should construct a model of the best design of their payloads. The model should fit into a #10 can (approximately 1 gallon) and be constructed from materials such as cardboard, aluminum foil, Mylar, paper, monocoat and similar materials. Extra points may be given for models that contain movable parts, such as retractable solar arrays.

#### CLOSURE:

Ask students to share information from the research and present models of payloads to the entire class.

**EVALUATION:**

Students should be evaluated based on the:

- Completion of Launch Log 3.1.
- Participation in construction of model payload.

**EXTENSION:**

An advanced activity for this lesson might be the construction of a robotic arm that could be used to deploy the model payloads.

**NOTES**

## SECTION 3

# PAYLOAD AND RECOVERY

### Activity 2 - Payloads for Model Rockets

---

**OBJECTIVES:**

By the end of this lesson, the student will be able to:

- Determine the effects of payload on altitude.
- Determine the effects of payload on CP and CG.

**BACKGROUND FOR THE TEACHER:**

While it is exciting to watch rocket launches, both full size and models, space transportation agencies would be unable to stay in business without the ability to launch a payload. In fact, the primary purpose of any transportation system is to carry a payload or passengers and space transportation systems are no exceptions. However, payloads and passengers add additional weight to the rockets and require careful calculations to insure successful launches. In this activity, the class will make multiple launches of a rocket, each with a different payload, graph the results and discuss the findings. Prior to each launch, the stability of the rocket must be checked to insure a safe launch. If necessary, refer to Section 2.4 “Center of Pressure and Center of Gravity” for a review on determining rocket stability. For advanced students, the teacher may wish to have the students make predictions based on information found in “Technical Report TR-10 Altitude Prediction Charts” and “Mathematics and Model Rockets”, both from Estes.

**VOCABULARY:**

**Altitude** - The measure of the vertical distance of a rocket from earth.

**Center of gravity** - The point in a rocket around which its weight is evenly balanced; the point at which a model rocket will balance on a knife edge; the point at which the mass of the rocket seems to be centered. Abbreviation: CG. Icon: 

**Center of mass** - The point at which the mass of an object is evenly balanced.

## STRATEGY:

**Materials needed for each student:** A copy of Technical Note TN-4 “The Fine Art of Payload Launching” and Technical Report TR-1 “Basic Rocket Stability” from Estes’ “The Classic Collection”; Launch Log 3.2, “Payloads and Effects on Altitude”.

**Materials needed for entire class:** Several B6-4 engines, completed Super Nova Payloader™ model rocket (constructed in advance by the teacher), Altitrak™ altitude finder, digital stop watch, wax paper, tissue paper and modeling clay.

1. Distribute copies of Technical Note TN-4 “The Fine Art of Payload Launching” and Technical Report TR-1 “Basic Rocket Stability.” As the students read about payload launching, each student should complete the top half of Launch Log 3.2.

**Motivation:** To simulate the effects of a payload on a rocket, time 2 or 3 students in a 30 or 40 yard dash. Have the students repeat the race with loaded booksacks on their backs. Compare the differences in the times and discuss the results. This should help students understand the additional requirements placed upon a rocket with a heavy payload.

2. Launch the empty rocket, measure the altitude, and record the results (refer to Technical Report TR-3 “Altitude Tracking” if necessary).
3. Roll 1oz. of modeling clay in wax paper and place in the LOWER end of the payload compartment of the rocket. Pack the remaining area of the payload compartment with tissue paper and reattach to the rocket.
4. Perform a “swing test” to check stability of the rocket (refer to Technical Report TR-1 “Basic Rocket Stability” if necessary). Do not launch if unstable!
5. Launch the rocket with its payload, measure the altitude and record the results.
6. Repeat steps 3 - 5. Each time increasing the amount of modeling clay by 1oz. until the maximum weight (rocket and payload) for the specific engine is achieved.

## CLOSURE:

Return to the class and have students graph the results of the payload launches on Launch Log 3.2. Discuss the similarities between the foot race and the rockets launched with payloads.

## EVALUATION:

Students should be evaluated based on the:

- Completion of Launch Log 3.2.

## EXTENSION:

An additional activity for this lesson might be a contest in which teams attempt to predict the altitude of a rocket with a predetermined payload after measuring the altitude of the empty rocket.

## NOTES

# SECTION 3

## PAYLOAD AND RECOVERY

### Activity 3 - Research and Test Various Recovery Designs

---

#### OBJECTIVES:

By the end of this lesson, the student will be able to:

- Identify and evaluate the six main types of recovery systems used by model rockets.
- Design and evaluate various parachute designs.

#### BACKGROUND FOR THE TEACHER:

While the primary purpose of a recovery system is to insure the safe return of a rocket to Earth, there may be times in which a quicker descent may be desired. Several factors, such as the size of your launch area, wind velocity, weight of your rocket and size of your engine may dictate a recovery system which produces less drag. Two methods of reducing drag in a parachute recovery system are shortening the shroud lines and cutting a circular hole in the center of the parachute.

#### VOCABULARY:

**Featherweight recovery** - Rocket recovery system which involves a very lightweight model which simply falls to the ground.

**Glide recovery** - Rocket recovery system in which the engine's ejection charge causes it to convert into a glider and which creates lift as it flies through the air.

**Helicopter recovery** - Rocket recovery system in which vanes on the rocket are activated by the engine's ejection charge. The vanes are surfaces mounted on the rocket in such a way that air flowing over them generates lift, which causes the rocket to rotate (like a helicopter) to the ground.

**Parachute recovery** - Rocket recovery system in which a parachute is attached to the rocket and ejected from the rocket by the engine's ejection charge.

**Streamer recovery** - Rocket recovery system in which a streamer (long ribbon producing drag to slow the descent) is attached to the rocket and ejected from the rocket by the engine's ejection charge.

**Tumble recovery** - Rocket recovery system in which the balance point of the rocket is moved causing it to be unstable so that it tumbles end over end creating drag to slow its descent.

#### STRATEGY:

**Materials needed for each student:** From the Estes "The Classic Collection" copy of Technical Note TN-3 "Is that Parachute Too Big" and Technical Note TN-6 "Recovery Techniques"; Launch Log 3.3A, "Recovery Systems"; Launch Log 3.3B, "Parachute Design and Evaluation", and TR3.3.

**Materials needed for each team:** Graph paper; materials necessary to construct and test five different parachute recovery systems.

**Materials needed for entire class:** Digital stop watch, two screw eyes, a spring type clothes pin and nylon cord to prepare parachute testing area, TR 3.3; "Reducing Drag in Parachute Recovery Systems."

**Motivation:** Students should work in small teams (2 or 3 students per team) to design and evaluate several designs for parachute recovery systems for a rocket. Because students like to compete, a contest which identifies the best parachute designs should provide excellent motivation for completion of this activity.

1. Distribute copies of Technical Note TN-3 "Is that Parachute Too Big" and Technical Note TN-6 "Recovery Techniques." As the students read about recovery systems, each student should com-

plete Launch Log 3.3A. After all students have completed the Launch Log, the entire class should discuss the advantages and disadvantages of each recovery system.

2. Discuss instances in which a large parachute might cause problems in recovering a rocket. Display Overhead Transparency 3.3 and discuss the methods of reducing drag in parachute recovery systems.
3. Depending on grade level and/or the students' ability, discuss with the class the methods for calculating the surface area of the parachutes to be tested. Teachers with younger students may wish to have students design the parachutes on graph paper with 1/4" or 1/2" squares and simply count the squares to calculate the surface area. More advanced students might be required to use geometric formulas to make their calculations.
4. Students should be given guidelines for the parachutes to be constructed and tested. Parachutes might be 12"-16" across with 12" shroud lines. Paper clips should be tied to the lower end of the shroud lines to allow for attachment of bell shaped lead weight. Lead weight available from any place that sells fishing supplies.
5. Demonstrate the procedure for the testing of the parachutes.
6. Divide students into small teams (preferably 2 or 3 per team) and distribute materials needed to construct five parachutes per team.
7. Each team of students should design five different parachutes and calculate the surface area of each of the designs on Launch Log 3.3B. The teacher should check the calculations before students are allowed to construct parachutes.
8. Each team should construct and test each of its five designs and record the results on Launch Log 3.3B.

#### **CLOSURE:**

Each team should present the results of their tests to the class and discuss the possible reasons for various parachute performances.

#### **EVALUATION:**

Students should be evaluated based on the:

- Completion of Launch Log 3.3A.
- Calculations of surface area of parachute designs.
- Testing of parachute designs.

#### **EXTENSION:**

An advanced activity for this lesson might be a contest in which teams select a recovery system for a rocket and attempt to have it land as close as possible to a predetermined target area. Each team should be given several attempts to make necessary adjustments.

#### **NOTES**

# SECTION 3

## PAYLOAD AND RECOVERY

### Activity 4 - Develop a Glider Recovery System

---

#### OBJECTIVES:

By the end of this lesson, the student will be able to:

- Identify the different recovery systems used by the space shuttle.
- Identify the advantages of using a glider recovery system.
- Build and launch a piggy-backed parasite glider.

#### BACKGROUND FOR THE TEACHER:

The space shuttle takes advantage of more than one recovery system. The large external fuel tank burns up on re-entry. The two solid rocket boosters use a parachute recovery system which allows them to be serviced and reused. The orbiter uses the same recovery system we will be using in this activity, glider recovery. The rocket used in the activity closely simulates the recovery systems used by the space shuttle. It has a booster that returns to earth with a parachute recovery and a detachable glider that floats back to earth.

#### STRATEGY:

**Materials needed for entire class:** Several engines, completed Space Shuttle™ Starter Set, launch pad, hot glue gun, styrofoam meat trays.

**Motivation:** Discuss with the class the different recovery systems used by the space shuttle and why there are multiple recovery systems employed.

1. Discuss the different factors that must be considered when using a glider recovery system, such as, wind direction and speed, size of launch area and location of surrounding buildings.
2. As a class, launch the Space Shuttle™ rocket.
3. Divide students into teams of 2 or 3 students per team.
4. Have each team design, build and test a glider built from styrofoam meat trays. Scissors make nice clean cuts on styrofoam meat trays and the various parts may be attached using hot glue.  
**CAUTION:** Do not use any metal parts on the glider.
5. Gliders should be tested and adjusted prior to launch.

#### NOTES

# SECTION 4

## MODEL CONSTRUCTION

### Activity 1 - Constructing a Model from a Kit

---

#### OBJECTIVES:

By the end of this lesson, the student will be able to:

- Identify the different materials used to construct a model rocket.
- Identify the various parts of a model rocket and their functions.
- Demonstrate safe use of tools and materials during the construction of a model rocket.
- Utilize workmanship and finishing techniques that will enhance the rockets performance.

#### BACKGROUND FOR THE TEACHER:

Some of the skills used in this activity were covered in earlier sections of this guide. If necessary, review the following sections; 2.2 “Design considerations for fins”, 2.3 “Design considerations for nose cones” and 3.3 “Research and test various recovery systems.”

#### VOCABULARY:

**Balsa Wood** - A very light, strong wood grown in Ecuador and used in the structure of model airplanes and model rockets.

**Body Tube** - A specially wound and treated cardboard or plastic cylinder used to make the fuselage or airframe of a model rocket.

**Engine Mount Assembly** - Safely secures the engine in a model rocket.

**Fins** - The stabilizing and guiding unit of a model rocket; an aerodynamic surface projecting from the rocket body for the purpose of giving the rocket directional stability.

**Launch Lug** - Round, hollow tube (attached to the model rocket) which slips over the launch rod to guide the model during the first few feet of flight until sufficient airspeed is reached allowing the fins to operate.

**Nose Cone** - The foremost surface of a model rocket that is shaped to reduce drag. Usually made of balsa or plastic.

**Parachute** - A drag producing device, generally hemispherical (half-sphere) in shape. Parachutes used in model rockets are generally made from light plastic and are used to gently recover the payload package, rocket body, etc.

**Recovery System** - A device incorporated into a model rocket for the purpose of returning it to the ground in a safe manner. Usually achieved by creating drag or lift to oppose the acceleration of gravity. All models must employ a recovery system, such as a parachute.

**Shock Cord** - The elastic cord used to attach the recovery system to the body of the rocket. Its elasticity absorbs shock when the recovery system deploys.

**Shock Cord Mount** - Used to attach the shock cord to the interior of the body tube.

**Shroud Line** - The cord or string used to attach the parachute to the nose cone.

#### STRATEGY:

**Materials needed for each student:** Launch Log 4.1.

**Materials needed for each team:** Materials from the Estes Alpha® Bulk Pack, copy of instructions included in the Estes Alpha® Bulk Pack, glue (white or yellow), scissors, sandpaper, masking tape, enamel spray paint (several colors), sanding sealer or primer, hobby knife, ruler.

**Materials needed for entire class:** Overhead Transparency TR4.1A, Overhead Transparency TR4.1B, Estes Alpha® Bulk Pack, Phantom™ non-flying model rocket.

**Motivation:** If you have not already done so in an earlier lesson, take the class outside and launch a model rocket. This should provide all the motivation necessary for this activity.

1. Show the class the Phantom™ non-flying model rocket. This clear model rocket makes viewing of the various parts of a model rocket easier.
2. After everyone has had a chance to view the Phantom™, show Overhead Transparency TR4.1A. Identify and discuss the purpose of each of the model rocket's parts. If available, pass out several previously built rockets for the students to use to identify the various parts.

3. Distribute Launch Log 4.1. As students review the vocabulary, they should identify the parts of a model rocket on page 2 and complete the crossword puzzle.

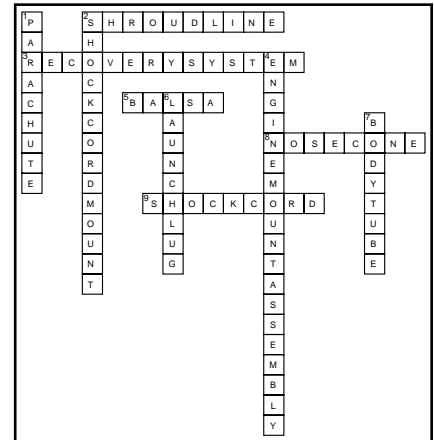

4. Fin alignment problems are common among beginning model builders. Show Overhead Transparency TR4.1B and discuss ways of avoiding these problems.

5. Review safety procedures for any specialized equipment in your lab to be used during the construction of the model rockets.

6. Demonstrate the safe use of the hobby knife and emphasize the following:  
Always exercise care when using a hobby knife (they are very sharp!) and don't leave the knife laying around after you finish with it. Use some sort of cutting board under the knife. A smooth flat piece of board is great; an old phone book or a thick catalog also works well on a hard surface.

7. The remainder of this activity will be used to construct model rockets from the Estes Alpha® Bulk Pack. This kit contains parts to build twelve of rockets and contains written instructions that may be used by individuals, small groups or entire classes. Most teachers allow individual students to build separate rockets.

**CLOSURE:**

After showing the completed rockets to the class, the rockets should be stored until the procedures for a safe launch are covered in Section 6.1 of this guide.

**EVALUATION:**

Students should be evaluated based on the:

- Completion of Launch Log 4.1.
- Quality of construction of the model rockets.

**EXTENSION:**

An advanced activity for this lesson might include the planning and construction of multi-stage model rockets. This would provide an opportunity for advanced students to research the procedures necessary to construct these rockets.

**NOTES**



# SECTION 4

## MODEL CONSTRUCTION

### Activity 2 - Construct Several Prototypes and Select the Best One

---

#### OBJECTIVES:

By the end of this lesson, the student will be able to:

- Use the Designer’s Special™ kit to build several difference model rockets.
- Determine the criteria to be used in evaluating the various models.
- Evaluate the various models to determine the best design.

#### BACKGROUND FOR THE TEACHER:

The class will build several prototypes of models rockets to be evaluated based on criteria established by the class. The class will select a “best” prototype to be used in activity 4.3 “Manufacturing applications of model rocketry.”

#### VOCABULARY:

**Prototype** - A full-sized, working model of a product that is built and tested prior to beginning production.

#### STRATEGY:

**Materials needed for each student:** Launch Log 4.2

**Materials needed for entire class:** Estes Designer’s Special™ kit.

**Motivation:** Teams of students will compete to build the best prototype for a model rocket kit. The teacher may also wish to recognize outstanding performance in categories such as “Most Original Design”, “Easiest to Construct”, etc.

1. Explain to the class that a fictional company has contracted with this class to develop a new model rocket kit that will go into production early next year. It is the responsibility of this class to build several difference model rockets, determine the criteria to be used in evaluating the various models, evaluate the various models to determine the best design.
2. Divide the class into teams of 3 to 6 students per team and give each student a copy of Launch Log 4.2.
3. Each team must outline what they believe to be the necessary criteria for evaluating the various prototypes. Each team’s criteria should be recorded on Launch Log 4.2.
4. Each team should select a representative to help select the criteria to be used by the entire class. Each representative will convey his/her team’s criteria to the group of representatives. This group should reach a consensus on exactly what criteria will be used to evaluate all the prototypes.
5. While the representatives are working on the evaluation criteria, the remainder of the students will work with their teams on thumbnails sketches for possible prototypes. The thumbnail sketches will be drawn on Launch Log 4.2.
6. Once a criteria for evaluation of the prototypes has been established, each team should make a full-sized drawing of the proposed model rocket.

7. After receiving the teacher's approval of the design, the team may begin constructing their prototype.

### **CLOSURE:**

Each team should present their prototype of the model rocket to the class for evaluation. If the evaluation includes launching the model rocket, the class may wish to review the safe procedures for launching a model rocket in section 6.1 "Preparing to Launch." Additionally, the teacher may wish to have individuals outside the class participate in the evaluation.

### **EVALUATION:**

Students should be evaluated based on the:

- Completion of Launch Log 4.2.
- Design and construction of the model rocket prototype.

## **NOTES**

# **SECTION 4 MODEL CONSTRUCTION**

## **Activity 3 - Manufacturing Applications of Model Rocketry**

---

### **OBJECTIVES:**

By the end of this lesson, the student will be able to:

- Select a name for the new rocket design.
- Develop a complete set of instructions and parts list necessary to construct a model rocket kit.
- Design package for the new rocket design.
- Develop a flowchart to be used during the packaging of a model rocket kit.
- Setup an assembly line for the packaging of the new model rocket kit.

### **BACKGROUND FOR THE TEACHER:**

You may want to give your students a brief introduction to mass production as a part of this lesson. In this activity, your class will package a model rocket kit for the fictional company from activity 4.2.

### **VOCABULARY:**

**Assembly line** - A line of workers and equipment on which the product being assembled passes continuously from operation to operation.

**Flowchart** - Diagram showing all the steps necessary to produce a product, useful in deciding what resources are needed.

### **STRATEGY:**

**Materials needed:** Parts necessary to assemble enough kits for each student in the class, materials to create a package for each kit, TR 4.3A and TR 4.3B.

1. Present a scenario to the class that the company that contracted with this class to develop a new model rocket kit has accepted their design. The company would now like the class to produce a package for the new kit.
2. Although the package for the rocket may be a box, plastic bag or other form of packaging, show the class Overhead Transparency TR4.3A. This transparency shows how one type of box is cut and assembled. Discuss with the class the many purposes of a package. These include: to protect the product, make the product easy to transport, promote the product and provide information about the product.
3. Using the symbols on Overhead Transparency TR4.3B, demonstrate how to develop a flowchart for some process in the classroom. You may wish to assign a sample exercise of developing a simple flowchart at this time.
4. Divide the class into 3 groups.
5. The first group has the responsibility of selecting a name and designing a package for the new model rocket kit.
6. The second group must develop a complete set of instructions and parts list necessary to construct the new model rocket kit. If computers are available, these should be developed using a word processor or graphics/desktop publishing program. This will facilitate editing, if necessary.
7. The final group will develop a flowchart to be used during the packaging of a model rocket kit and setup an assembly line for the packaging of the new model rocket kit.

**CLOSURE:**

The teams should reassemble and package enough kits for each student in the class.

**EVALUATION:**

Students should be evaluated based on the:

- Completion of the group's assignment.

**NOTES**

# SECTION 5

## DESIGN AND ENGINEERING

### Activity 1 - Designing

---

#### OBJECTIVES:

By the end of this activity, the student will be able to:

- Use standard mechanical or CAD drawing principles to develop detail drawings for a completed model rocket kit.
- Use standard mechanical or CAD drawing techniques to develop detailed drawings of existing kit parts.
- Use standard mechanical or CAD drawing principles to develop an assembly drawing for a selected model rocket kit.
- Use standard mechanical or CAD drawing principles to develop a detailed cutaway drawing of a standard model rocket engine.
- Use standard 3D CAD principles to develop a 3D drawing of a model rocket kit.

#### BACKGROUND FOR THE TEACHER:

All man made objects, whether small ball point pens or rockets, have been created through a design process. This process encompasses many hours of work on the part of numerous individuals. By engineers and designers coordinating their efforts, large scale projects like the space shuttle, are possible. This activity will help students to transfer knowledge and skills that they have developed previously in design and engineering. It is assumed that students attempting this activity have a basic understanding and working knowledge of either mechanical drawing and/or CAD principles and techniques. During this activity, students will be asked to develop detailed drawings, assembly drawings, cutaway drawings, and if available, 3D CAD drawings.

#### VOCABULARY:

**Computer Aided Design:** The use of the computer to create and edit drawings.

#### STRATEGY:

**Materials needed for each student:** Each student will need to have a model rocket kit, drafting tools (including a drafting table or board, T-square and triangle or drafting machine, scale, French curve, and compass) or CAD station, drafting or plotter paper, TR 5.1 (cut away of a model rocket engine).

**Motivation:** Students should be encouraged to become part of the “design and engineering team.” Any large scale project, such as designing a rocket or airplane involves thousands of hours of time by a dedicated team of designers and engineers. The class may be divided up into sub-teams to work on specific sections of the rocket design. If so, then the teams will need to communicate with each other during the design and engineering phase to ensure that the parts from each sub-team are compatible with each other. If there are enough students in the class, the class can be divided into competing teams. The teacher can then see which team develops the neatest and most precise set of plans.

1. If so desired, set up students into teams and/or sub-teams. Discuss the importance of teamwork and coordination.

2. Distribute the rocket kits to each student or team of students and make sure that each student understands the function of each part. If the students are working as teams, then you will need to make assignments of various parts to each team member.
3. Using either CAD or traditional drafting methods, each student should then draw detailed drawings of the assigned parts including required dimensions and necessary notes. It would be beneficial and motivational to plot/print the drawings.
4. Using either CAD or traditional drafting methods, each student should now draw a detailed drawing of a completed model rocket kit. The drawing should include required dimensions and necessary notes. Because of the symmetry of the model rocket, you may wish to require only a side or a side and top view. It would be beneficial and motivational to plot/print the drawings.
5. Using TR 5.1, have each student develop a detailed cutaway drawing of a model rocket engine. If the students are using CAD, each section of the engine should be crosshatched in a different pattern or designated by different colors. It would be beneficial and motivational to plot/print the drawings.
6. For more advanced students, the detailed parts drawings can be used to develop an exploded assembly drawing of a completed model rocket kit. It would be beneficial and motivational to plot/print the drawings.
7. Another activity for advanced students would be the creation of a 3D model of a model rocket. The use of a 3D CAD program, such as AutoCAD®, VersaCAD®, CADKey® or one of the other 3D CAD programs that are available would be necessary to generate the drawings. Once the wire-frame has been developed, the students can then hide lines, render, shade and use other CAD features that are available on the particular software that is being used. It would be beneficial and motivational to plot/print the drawings.

### **CLOSURE:**

Review with the students the importance of working as a team in a large scale project. Completed drawings can be placed on display throughout the school.

### **EVALUATION:**

Students should be evaluated based on the:

- Completion of detailed drawings, using acceptable drawing principles.
- Completion of assembly drawings, using acceptable drawing principles
- Completion of cutaway drawings, using acceptable drawing principles.
- Completion of 3D drawings of a model rocket, using acceptable drawing principles.

### **EXTENSION:**

As an extension to this activity, contact NASA (see appendix) or an aerospace contractor and request copies of any detailed drawings that they may have available. These drawings can be analyzed by the students and used as a motivational tool throughout the year. If your school is fortunate enough to be in a location where there are companies that specialize in aerospace design, contact one of them and set up a tour of their facilities. If they are not able to allow your group to tour, they may be able to send a member of their design or engineering team to your school for a presentation or have a video tape available that will show your students what is involved in the design and engineering phases of the aerospace industry.

## NOTES

# SECTION 5

## DESIGN AND ENGINEERING

### Activity 2 - Materials List

---

#### OBJECTIVES:

By the end of this activity, the student will be able to:

- Generate a bill of materials for a model rocket kit.
- Estimate the cost of materials for a given number of model rockets.

#### BACKGROUND FOR THE TEACHER:

Once the design phase of a project has been completed, a list of materials must be generated and the cost of the project estimated. This is true whether you are building a house, a car or a rocket. While all of the materials necessary for a model rocket kit are generally included as part of the kit, it is good for the student to be able to take a drawing and be able to generate a complete bill of materials for the project. In addition, by using catalogs as a reference, students can then estimate the cost of the rocket if they were purchased at individual prices rather than as a kit. For those classes who are planning an assembly line activity with model rockets and possibly selling the completed project, information has been included in an advanced activity to calculate the break-even point of the project.

#### VOCABULARY:

**Bill of materials:** A listing of all of the materials necessary to complete a project. The bill of materials generally includes the quantity, description and size of the materials needed.

**Break even point:** That point where in a manufacturing or sales endeavor where all costs have been paid back and a profit begins to be made (for advanced students).

**Estimate:** To approximate the cost of materials necessary for completing a project.

#### STRATEGY:

**Materials needed for each student:** Each student will need to have a detailed drawing of the rocket under study, Launch Log 5.2A, Launch Log 5.2B, an Estes model rocket catalog and a price list.

**Motivation:** Many times, when materials are packaged as kits, the cost of the materials can be reduced. On other occasions, when a large quantity of materials are required, materials purchased in bulk quantities may be more cost effective than those purchased as a pre-packaged kit. To help determine which is the most effective way to purchase the model rockets that your classes will be constructing, the students can generate a bill of materials from the drawings that they created earlier (if activity 4.1 was not completed this can still be done through Estes model rocket kit instructions). Cost estimates can be generated either on paper or by using a computer spreadsheet.

1. Supply each student with a detailed drawing of the rocket under study and Launch Log 5.2A. Have each student complete Launch Log 5.2A (Bill of Materials) for the model rocket under study.

2. Once the bill of materials has been completed (Launch Log 5.2A), hand out Launch Log 5.2B, the Estes model rocket catalog and the price list. Have the class determine the total number of model rocket kits that need to be built. Based on the number of model rocket kits that need to be built, have each student prepare an estimate of the cost of the materials needed to complete the model rocket project.
3. As an advanced part of this activity, if your class is going to try to “sell” the model rocket then, based on the cost of materials determine the break even point for selling the model rockets. Make sure that your students include overhead that is involved in the production of the model rockets in their calculations. To calculate the break even point they can use the following formula:

$$B = \frac{F}{(S - C)}$$

To calculate the profit at a specified number of units sold you can use the following formula:

$$P = (S * U) - F - (C * U)$$

B = Break even point

F = Fixed costs

S = Selling price

C = Variable costs

U = Number of units

P = Profit

Once the break-even calculations have been made, the students can graph the information to better see where the break-even point is. If you are going to do a lot of calculations, you may wish to use a spreadsheet. Many spreadsheets will also graph the data, which will give an added dimension to the project

### **CLOSURE:**

Discuss with the class the results of their materials lists and cost estimations. You may also wish to review with your students the importance of keeping accurate records of the materials used, the problems due to waste or scrap materials and the costs associated with a project. Discuss the problems associated with cost overruns on large scale projects. You may also wish to try to determine how accurate their cost estimates are. When the project has been completed, you can go back to their estimates to determine their cost overruns and what factors contributed to them.

If your class completed this activity to determine the potential profit in a model rocket project then this would be a good time to discuss the factors involved in the costs of completing the project.

### **EVALUATION:**

Students should be evaluated based on the:

- Completion of the materials list, Launch Log 5.2A.
- Completion of the cost estimation sheet, Launch Log 5.2B.

**EXTENSION:**

As an extension to this activity, have the students research large scale projects such as a schools, hospitals, aircraft, roads, etc. to determine if any of these projects had cost overruns associated with them and what factors led to those overruns. The students could play the role of a reporter and write a short “article” that informs the public about the cost of the project.

**NOTES**

## SECTION 5

# DESIGN AND ENGINEERING

### **Activity 3 - Computer Animation**

---

**OBJECTIVES:**

By the end of this activity, the student will be able to:

- Develop a series of animation cels that follows a model rocket through the launch preparation flow.
- Develop a series of animation cels that explains model rocket safety.
- Develop a series of animation cels that follows a model rocket through the launch sequence.
- Develop a series of animation cels that shows a model rocket engine firing sequence.
- Develop a series of animation cels that follows a model rocket through the flight and recovery sequences.

**BACKGROUND FOR THE TEACHER:**

Computer animation and multimedia development tools have become almost commonplace in many technology classrooms. These tools can be used as both presentation tools for the classroom and for student instruction. By assigning students to develop animation cels to demonstrate different aspects of model rocketry, the students will not only gain an understanding of the model rocketry concepts, but will also gain skill in the use of the computer animation or multimedia development tools. For those classrooms who are not as fortunate to have these development tools, the basic concepts of animation can be demonstrated through the use of the pen. Flip cards can be developed by students to demonstrate an understanding of the basic concepts of both model rocketry and animation. So the question is not if you have computer animation or multimedia in your classroom, but rather how to best approach this topic in relation to model rockets.

**VOCABULARY:**

**Animation:** A series of cels that change at a rapid rate to make a set of graphic images appear to move.

**Cels:** A single sheet or layer where the graphic elements are “painted”. In computer animation a cel is a single screen of graphic elements.

**Graphic Element:** The smallest unit of a graphic design; a line is an example of a graphic element.

**Multimedia:** Using the computer in conjunction with other electronic devices to present an idea.

Many times it includes computer slides or movies and audio.



## STRATEGY:

**Materials needed for each student:** Depending on the level of technology, each student will need:

- For classrooms that do not have computer animation/multimedia software available: storyboard sheets, flipcard and Launch Log 5.3.
- For classrooms that have computer animation/multimedia software available: storyboard sheets, computer, animation/multimedia software and Launch Log 5.3.

**Motivation:** Students are often excited and motivated when presented with a new challenge. Animating a model rocket sequence can be one of those challenges. Because every computer animation development tool is different, we cannot present step by step directions for these animations, however, we can offer you some tips to keep in mind when presenting this activity. If your school is not fortunate enough to have access to these development tools, most every part of this activity can be completed through the use of flipcards. These flipcards are just a series of sheets of paper that the students draws on and then flips through to “view” the animation.

1. The launch preparation flow consists of the steps leading up to the launch of a model rocket. These steps include the insertion of the flameproof wadding, preparation of the recovery system (streamer, parachute, etc.), insertion of the model rocket engines, igniter and the preparation of the model rocket onto the launch pad. If they have not already had a firm background in the launch preparation flow of a model rocket, have students research the launch preparation flow of a model rocket. Once they have an understanding of the launch preparation flow they should use the storyboard, Launch Log 5.3, to develop the story line for their animated cels. After the storyboards have been completed, the students can then move to the computer and develop their animation cels.
2. The model rocket safety code is an important document, however, just reading over a list of rules does not motivate students to remember them nearly as well as “doing” something with the rules. Divide the class up into groups and assign each group one or more of the rules listed in the model rocket safety code, TR6.1A. If your students are using a computer animation program to develop cels that will demonstrate the code they can combine several of the cel sequences together to make a completed animation that describes several related model rocket safety code concepts. As with any of these animations, they can be sent to tape and played back to the whole class.
3. The launch sequence of a model rocket begins with the final countdown, leading to the insertion of the safety key into the launch controller and is completed when the model rocket engine is fired and the model rocket lifts off of the launch pad. If they have not already had a firm background in the launch sequence of a model rocket, have students research the launch sequence. Once they have an understanding of the launch sequence they should use the storyboard, Launch Log 5.3, to develop the story line for their animated cels. After the storyboards have been completed, the students can then move to the computer and develop their animation cels.
4. Many times computer animated sequences can be used to demonstrate what cannot be seen. Students can only imagine what is happening inside a model rocket engine during launch, and so an animated sequence is a perfect way to have the students demonstrate their understanding of the model rocket engine firing sequence. If so desired, cels with the casing of the engine could be setup ahead of time to save the student time in animation development. Once they have an understanding of the launch sequence they should use the storyboard, Launch Log 5.3, to develop the story line for their animated cels. Have each student research the firing sequence of the engine and then develop animation cels that demonstrate that sequence.

5. Perhaps the most exciting part of model rocketry is the actual flight and recovery of the model rocket. Have the students research the flight and recovery stages. Once they have an understanding of the launch sequence they should use the storyboard, Launch Log 5.3, to develop the story line for their animated cels. They can then develop animation cels that demonstrate all of the aspects of a normal flight. If you wish, you can discuss potential flight and recovery problems and use computer animations to demonstrate a “what-if” scenario.

**CLOSURE:**

Discuss the importance the animation of computerized presentations in a virtual world. Have the students demonstrate their understanding of not only computer animation but the various aspects of model rocketry that have been addressed in this activity.

**EVALUATION:**

Students should be evaluated based on the:

- Completed animated cells and animations.
- Their understanding of the model rocketry concepts addresssed in this activity.

**EXTENSION:**

As an extension to this activity, your students could develop cel animations using transparencies. They should “paint” on the transparencies with a marker or acrylic paint. These cels should then be video taped and played back like an animated movie.

**NOTES**

# SECTION 6

## DYNAMIC TESTING

### Activity 1 - Preparing to Launch

---

#### OBJECTIVES:

By the end of this lesson, the student will be able to:

- Demonstrate NAR Model Rocketry Safety Code and complete a Flight Readiness Review (FRR).
- Analyze weather conditions and determine suitability for launch.
- Identify the conditions requiring FAA clearance and obtain clearance if necessary.

#### BACKGROUND FOR THE TEACHER:

Launching a rocket, model or full-sized, requires a great deal of attention to safety. This activity will make students aware of the factors important to consider when preparing to launch a model rocket. The safety code covered in this lesson is the official Model Rocketry Safety Code of the National Association of Rocketry and Model Rocket Manufacturers Association and was formulated by experienced rocketeers and has evolved with model rocketry. It should be followed in every model rocketry activity.

#### VOCABULARY:

**FAA** - Federal Aviation Administration

**newton** - The unit of force required to accelerate a mass of one kilogram at the rate of one meter per second per second; one newton is equal to 0.225 pounds of force. Abbreviation: n.

#### STRATEGY:

**Materials needed for each student:** Launch Log 6.1., Estes Model Rocket Flight Data Sheet (EST 2824).

**Materials needed for entire class:** Overhead Transparency TR6.1A “NAR Model Rocketry Safety Code”, Overhead Transparency TR6.1B “Estes Model Rocket Flight Data Sheet.”

1. Using Overhead Transparency TR6.1A, discuss with the class each portion of the “NAR Model Rocketry Safety Code.”
2. Distribute Launch Log 6.1 and allows students enough time to read the NAR Model Rocketry Safety Code and complete questions at the end of the Launch Log.
3. After the students have completed Launch Log 6.1, use a class discussion to check the students’ responses on Launch Log 6.1.
4. Using Overhead Transparency TR6.1B, discuss with the class the items on the Estes Model Rocket Flight Data Sheet.

#### CLOSURE:

Take the class to the proposed launch site, and complete a Flight Readiness review using the “NAR Model Rocketry Safety Code” and the “Estes Model Rocket Flight Data Sheet” as a guide.

#### EVALUATION:

Students should be evaluated based on the:

- Completion of Launch Log 6.1.
- A teacher made test on the NAR Model Rocketry Safety Code.

## NOTES

# SECTION 6 DYNAMIC TESTING

## **Activity 2 - Flight Mission Teams**

---

### **OBJECTIVES:**

By the end of this lesson, the student will be able to:

- Identify the various teams established by NASA to insure a successful mission.
- Determine the teams necessary for the completion of a successful mission of a model rocket.
- Identify the responsibilities and develop a checklist and flight data chart for each of these teams.

### **BACKGROUND FOR THE TEACHER:**

NASA and all the commercial space agencies require many teams of experts to insure the success of their space related missions. For example, the Launch Control team at Kennedy Space Center controls the space shuttle until the solid rocket boosters are ignited. From that point on, the Mission Control team in Houston has control of the space shuttle. Even after the return of the space shuttle, many teams must work diligently to compile data from the mission, return the space shuttle to Kennedy Space Center, and prepare the various components of the space transportation system for its next mission. This activity will provide your students with insight into the many careers available to individuals interested in aeronautics.

### **STRATEGY:**

**Materials needed for each student:** Launch Log 6.2.

**Materials needed for entire class:** Various equipment depending on the teams established.

**Motivation:** Although the teacher will be overseeing the mission, stress to the students that they will be controlling the upcoming mission. Let the teams of students have as much responsibility as you feel they can handle safely.

1. Discuss with the class the various teams established by NASA to insure a successful space shuttle mission. As a part of this discussion, determine the teams necessary for the completion of a successful mission of a model rocket. The number of teams established will depend on the size and maturity of the class. Listed below are some suggestions for possible teams.

**Mission control** - Controls mission from the time of launch to the end of the mission.

**Safety inspection teams** - Insures that rocket and launch pad are ready for a safe launch and checks weather conditions to determine suitability for safe launch. For more information on the responsibilities of this team, refer to section 6.1 of this guide.

**Flight preparation** - Makes final preparations of the rocket.

**Launch control** - Prepares launch pad for launch.

**Tracking** - Manual altitude tracking, flight duration and electronic tracking. For more information on the responsibilities of this team, refer to section 6.3 of this guide.

**Recovery** - Recovers and returns rocket at end of flight.

**Security** - Insures that nothing hampers the safety of the overall launch and mission. For more information on the responsibilities of this team, refer to section 9.4 of this guide.

**Data compilation** - Records and compiles all data collected during the mission.

**Payload** - Prepares payloads for launch. For more information on the responsibilities of this team, refer to section 3.2 of this guide.

**Communications** - Establishes and maintains communication network during mission. This team should establish a means of communication between the various other teams. These means of communication may include two-way radios, hand signals, Morse code (wired or flashes of light) and signal flags.

**Public information** - Collects and relays information about the mission to the public. For more information on the responsibilities of this team, refer to section 9.2 of this guide.

2. After deciding what teams will be needed, divide the class into the necessary number of groups. Please note, some teams may require as few as 2 members such as a data collector and a recorder, while some teams may require more members.
3. After the teams have been established, either the entire class or the individual teams will use Launch Log 6.2 to identify the responsibilities of each team to develop a checklist and flight data chart for each of these teams.

#### **CLOSURE:**

Once the checklists and flight data charts have been developed, take the class to the launch site for a dry run for each of the teams. This will provide an opportunity for all the groups to see what the other teams will be doing.

#### **EVALUATION:**

Students should be evaluated based on the:

- Completion of Launch Log 6.2.
- A teacher-made test.

#### **EXTENSION:**

The teams developed in this activity will be used when model rockets are launched in activity 6.3.

#### **NOTES**

# SECTION 6

## DYNAMIC TESTING

### Activity 3 - Tracking

---

#### OBJECTIVES:

By the end of this lesson, the student will be able to:

- Demonstrate tracking using single station or multi-station method.
- Determine the altitude of a rocket based on calculations made from data collected during flight.
- Graphically determine the altitude reached by a model rocket.

#### BACKGROUND FOR THE TEACHER:

It is possible for students of any grade level to accurately estimate the altitude of a model rocket's flight. The simplest method involves plotting the baseline on graph paper and using a protractor to find the altitude of the rocket. The most common method to find the altitude uses trigonometry. Every triangle has six parts, three sides and three angles. If we know two angles and one side, we can find the other angle and the other two sides. Finally, the most accurate method of finding a model rocket's altitude also uses trigonometry, but uses two tracking stations. This activity will give your students the opportunity to put each of these methods into practice. The instructions for this activity assumes that the teacher understands the three methods mentioned. It may be advisable for the teacher to review these methods of altitude tracking by reading Technical Report TR-3 "Altitude Tracking" from "The Classic Collection" prior to the start of this lesson.

#### VOCABULARY:

**Angular distance** - Determined by measuring the angle between the rocket's position on the launch pad and the highest point (apogee) reached by the rocket as seen by the tracking station or observer.

**Apogee** - The highest point reached during a model rocket's flight, measured from the surface of the earth.

**Baseline** - The distance between a tracker and the launch pad in tracking with one station. In tracking between two stations, it is the distance between tracker 1 and tracker 2.

**Tangent of angular distance** - In a right triangle, a function of an acute angle equal to the ratio of the side opposite the angle to the side adjacent to the angle.

#### STRATEGY:

**Materials needed for each student:** Graph paper, Launch Log 6.3A, Launch Log 6.3B, Technical Report TR-3 "Altitude Tracking."

**Materials needed for each team:** Checklists and charts from activity 6.2.

**Materials needed for entire class:** Several model rockets with launch related supplies, Estes AltiTrak™, Overhead Transparency TR6.3A, Overhead Transparency TR6.3B, Overhead Transparency TR6.3C.

**Motivation:** Every student wants build the best rocket in the class. Some students are only concerned with how a model rocket looks; however, most students want to build the model rocket that flies the highest. This activity will provide the students with the skills necessary to determine the class' highest flying model rocket.

1. Ask the class to estimate the height of the flag pole at your school. Take the class to view the flag pole (large tree or microwave tower) and ask each student to make a prediction about its height. You may wish to select a student to record these estimations.

2. Measure off 100 feet. Using the AltiTrak™, measure the angle from where you are standing to the top of the flag pole.
3. After returning to the class, distribute copies of Technical Report TR-3 “Altitude Tracking.” Students should read the first two pages of this report which includes the section on single station tacking.
4. Once the students have finished reading, use Overhead Transparency TR6.3A to demonstrate to the class the graphical method of finding the height of the flag pole. Compare the height with the students’ predictions.
5. Demonstrate the operation of the AltiTrak™.
6. After reviewing the NAR Safety Code, prepare a rocket for launch, establish a location for the tracking team (250-500 feet from the launch site), assign a tracking team and launch the model rocket. A good rule of thumb is to position the trackers the same distance away from the launch pad as the expected altitude.
7. Use Overhead Transparency TR6.3B to show the class how to graphically determine the altitude of the model rocket.
8. Distribute Launch Log 6.3A and several sheets of graph paper. Students should complete the exercises on graphically determining the height of several objects and the altitude of a model rocket. Remind students to refer to Technical Report TR-3 “Altitude Tracking” as needed.
9. Discuss with the class the results from the exercises on graphically determining the altitude of a model rocket.
10. Using Overhead Transparency TR6.3C, demonstrate to the class how to determine the altitude of a model rocket by using trigonometry.
11. Distribute Launch Log 6.3B. Students should calculate the altitude of the model rockets. Remind students to refer to Technical Report TR-3 “Altitude Tracking” as needed.
12. Discuss with the class the results from the exercises on calculating the altitude of a model rocket.

### **CLOSURE:**

Review the NAR safety code and prepare the model rockets from Section 4.1 for launch. The teams from Section 6.2 should reassemble and review the responsibilities for that team. Once the all teams are ready, launch the rockets and record all necessary data. When all the model rockets have been launched, return to the class and discuss the result of these missions.

### **EVALUATION:**

Students should be evaluated based on the:

- Completion of Launch Log 6.3.
- A teacher-made test
- Successful launch and recovery of model rockets.

### **EXTENSION:**

Advanced students in your class might read the section on two stage tracking in Technical Report TR-3

“Altitude Tracking” and determine a rocket’s altitude using this method.

The Transroc II™ from Estes allows for the tracking and recovery of lost rockets. A simulation of a military mission in which a pilot has been downed and is lost would provide an excellent opportunity to explore this additional dimension of tracking. Knowing the rocket’s position at parachute deployment, descent rates and wind conditions, the landing spot of the “downed pilot” can be predicted. Using the Transroc II™, the rocket can then be recovered.

Additional electronic tracking devices, such as recording altimeters, are available from:

Adept Rocketry  
2545 Overlook Drive  
Broomfield, CO 80020  
(303) 466-9605

Electronic altimeters from Adept Rocketry can report a flight’s maximum altitude up to 50,000 feet. Advanced students may wish to compare the results from this equipment with the other methods mentioned in this section.

The teacher may wish to have the class calculate the “launch to apogee” average speed and the “apogee to landing” average speed. The formula for making these calculations is *Average speed = Distance traveled ÷ Time traveled*.

Parachute ejects at apogee

$T_A$  = time at apogee

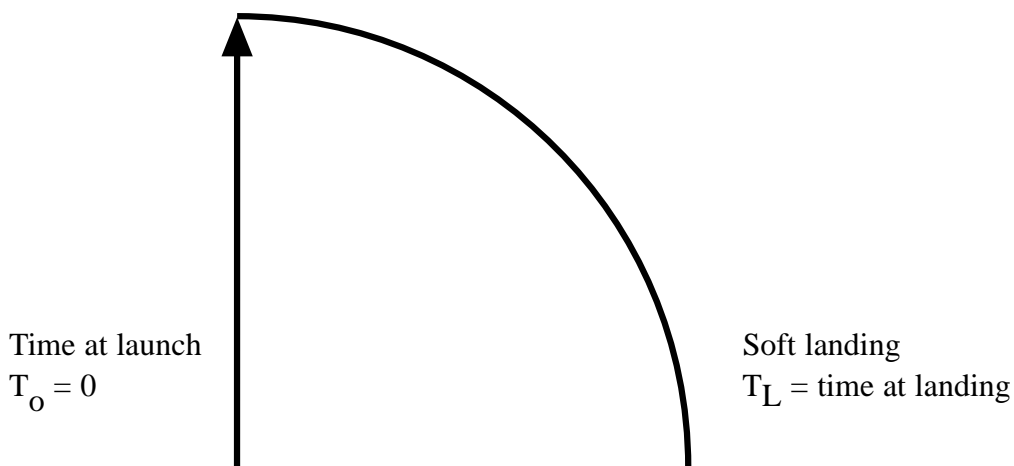

A Group Launch Data sheet is included in the appendix to record this data.

### NOTES



# SECTION 7

## PROPULSION

### Activity 1 - Rocket Engine Characteristics

---

#### OBJECTIVES:

By the end of this activity, the student will be able to:

- Identify various model rocket engines' characteristics by their engine coding designations.
- Explain model rocket engine's fundamental functions.
- Identify model rocket engine sections.
- Explain the purpose of the centerbore on a model rocket engine.
- Explain the purpose of the delay and tracking charges on a model rocket engine.

#### BACKGROUND FOR THE TEACHER:

Model rocket engine design has been standardized. Once the student has understood the various characteristics of model rocket engine design, then he/she will be able to transfer that knowledge to other engines. Engines are coded with an alphanumeric code that allows for easy engine identification. This code, when understood, will give the student important and useful data on the engine's characteristics. Please refer to Technical Note-1 (TN-1) in Estes' "The Classic Collection" (see appendix) for complete and detailed information on model rocket engines .

#### VOCABULARY:

**Burnout:** The point at which a rocket engine ceases to produce thrust. Generally, the point at which all propellant has been burned.

**Casing:** A paper cover that protects the charges of a rocket engine and confines the internal pressure during combustion allowing the exhaust gas to escape through the nozzle.

**Centerbore:** A depression or notch in the end of the propellant grain that provides easier ignition and a rapidly increasing propellant burn surface. This creates a high initial thrust which accelerates the rocket to a suitable flying speed quickly.

**Ceramic nozzle:** A device on the bottom end of an engine that channels the exhaust gas through the nozzle throat to greatly increase the exhaust gas speed which in turn develops thrust.

**Characteristics:** The attributes of one model rocket engine that makes it distinct from another.

**Delay and tracking charge:** A no thrust, slow burning charge that emits smoke to aid in tracking and allows the rocket to coast to a higher altitude before activation of the ejection charge for recovery system deployment.

**Ejection charge:** The charge contained in single and upper stage engines which deploys the recovery system.

**I. D.:** Inside diameter

**Igniter:** An electrical device which initiates the combustion process in a rocket engine.

**Ignition:** The instant at which a model rocket engine's propellant begins to burn.

**Model rocket engine coding:** A series of numbers and letters that serve to identify the engine's performance capabilities.

**Nozzle throat:** That portion of the ceramic nozzle that allows the exhaust to exit the engine. It is also where the igniter is placed.

**O. D.:** Outside diameter.

**Propellant:** A chemical paste of a combustible nature, that has been commercially developed and loaded in the casing of a model rocket engine that when ignited will provide the thrust necessary to launch a model rocket.

## STRATEGY:

**Materials needed:** Launch Logs 7.1A and 7.1B, TR7.1A, TR 7.1B, TR 7.1C, various model rocket engines, the Phantom™ see-through static display model or a teacher made model rocket engine cutaway model.

**Materials for each student team:** Toilet paper or paper towel tube and modeling clay (5 colors needed).

**Motivation:** Many students get excited when they discuss cars and car engines. Begin the discussion by asking them to brainstorm about various car engines and their designations. After the students have developed a list, direct the session attention towards rockets. You may wish to include both solid and liquid propellant rockets in the discussion. The characteristics needed for a rocket is dependent upon the purpose of the rocket and characteristics of the payload. A rocket that is designed to launch a sub-orbital probe will have much different characteristics than one that is used to put the Shuttle into orbit or put a probe on Saturn.

1. Discuss the model rocket engine color coding using various model rocket engines as examples. (TN-1).
2. Using TR7.1A discuss the engine code designation stamped on the side of the engine.
3. Using TR7.1B and the cutaway engine from the Phantom™ or a larger cutaway engine that you have developed, explain the following sections of the engine: ceramic nozzle, solid propellant, smoke tracking and delay element, ejection charge and the paper casing.
4. Divide students up into small teams (2 or 3 per team). Each team will make a cutaway of a model rocket engine from a toilet paper or paper towel tube and clay. Make sure that each team has the materials listed above. You will need to be sure to instruct the students on the safe use of sharp tools (knife or scissors) and other safety rules that you have for your technology lab. An additional task that the teams can do is to label each part of the cutaway.
5. Completed model rocket engine cutaways can be put on display.
6. Review the flight sequence of a model rocket (TR7.1C).
7. Students should next complete the Model Rocket Engine Cutaway Worksheet, Launch Log 7.1A.
8. Students should next complete the Model Rocket Engine Characteristics Crossword Puzzle, Launch Log 7.1B.

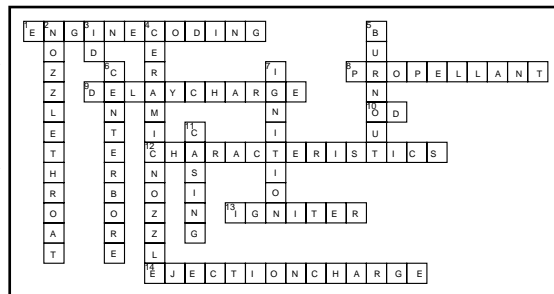

## CLOSURE:

Review the model rocket engine code, characteristics and model rocket engine cutaway models. Discuss the answers to Launch Logs 7.1A and 7.1B.

## EVALUATION:

Students should be evaluated based on the:

- Completion of the model rocket engine cutaway model
- Completion of Launch Log 7.1A
- Completion of Launch Log 7.1B.

## EXTENSION:

As an extension to this activity, advanced students can make a large model rocket engine cutaway model that can be used as a static display. They could use materials such as 3"-6" thin wall PVC pipe, plaster of paris, acrylic or other suitable materials.

## NOTES

# SECTION 7 PROPULSION

## **Activity 2 - Engine Selection**

---

### **OBJECTIVES:**

By the end of this activity, the student will be able to:

- Explain the important considerations in selecting a model rocket engine.
- Interpret the model rocket engine selection chart.
- Choose an appropriate model rocket engine for a specific model rocket.

### **BACKGROUND FOR THE TEACHER:**

Specific model rocket engine characteristics will determine the performance of a model rocket in flight. By choosing the correct model rocket engine for a specific model rocket, the student will be able to be more successful. While it is very difficult to pre-determine an altitude you can predict an altitude range. In addition to the weight and aerodynamics of the model rocket, mitigating factors such as the humidity, winds and the terrain all play a role in the performance of the model rocket in flight.

### **VOCABULARY:**

**Acceleration:** The rapid movement of a model rocket during the first seconds of a launch. The rate at which velocity changes.

**Burnout:** The point at which a rocket engine ceases to produce thrust. Generally, the point at which all propellant has been burned.

**Ejection charge:** The charge contained in single and upper stage engines which deploys the recovery system.

**newton-second:** The metric measurement of a model rocket engine's total impulse (power).

**pound-seconds:** The English measurement of a model rocket engine's total impulse (power).

**Specific impulse:** A measurement for determining the relative performance of a rocket propellant; the measure of total impulse per pound of propellant.

**Thrust-time curve:** A graphic expression of the relationship between thrust produced by a rocket engine and time; a graph showing the thrust produced by a model rocket engine at each instant of its operation.

**Thrust:** The propulsive force developed by an operating rocket engine caused by the rearward ejection of gasses during the combustion process.

**Total impulse:** The amount of thrust acting over a period of time developed by a rocket engine; determined by measuring the area under the engine's thrust-time curve; or by multiplying the average thrust by the burning time.

### **STRATEGY:**

**Materials needed:** Launch Logs 7.2A and 7.2B, TN-1 (see appendix), scale and various model rockets.

1. Using the engine selection chart in TN-1 (you may wish to make a copy of the chart for each

student), discuss the various things to consider when choosing a model rocket engine. Ask students to find these considerations on the chart. Also see TN-1 for more details on model rocket engine selection.

2. Ask the students to find a specific model rocket engine and tell you the important facts about that engine.
3. Give several examples where you have a model rocket of a specified weight that you wish to fly at a certain altitude range. Ask the students to offer suggestions as to which model rocket engine would be best suited for that flight.
4. Bring out several different model rockets. Ask students to determine which model rocket engine would be best suited for flight in a specific altitude range. Have the class complete Launch Log 7.2A.

5. Have the class complete the crossword puzzle, Launch Log 7.2B.

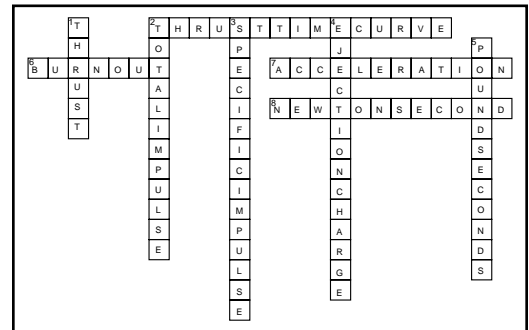

**CLOSURE:**

Review how to interpret the model rocket engine selection chart and the characteristics that are important to consider when selecting a model rocket engine.

**EVALUATION:**

Students should be evaluated based on the:

- Appropriate selection of a model rocket engine for a specified model rocket.

**NOTES**

**SECTION 7  
PROPULSION**

**Activity 3 - Static Engine Testing**

---

**OBJECTIVES:**

By the end of this activity, the student will be able to:

- Safely test various model rocket engines using a model rocket engine test stand.
- Gather the data from the static test of the model rocket engines.
- Analyze the data from the static test of the model rocket engines.

## BACKGROUND FOR THE TEACHER:

**Motivation:** When a new rocket engine has been developed for use by the Air Force or NASA, it must undergo a tremendous amount of testing. One type of test is a static test where the engine is placed in a stand and fired. During this firing, data is collected for later analysis. While a great deal of data has already been collected and analyzed in model rocketry, static testing can add a sense of excitement for the student. The model rocket engine selection chart offers data concerning the differences in various model rocket engines but it cannot demonstrate the differences in model rocket engine characteristics nearly as well as a model rocket engine static test stand

### Types of Tests that can be Conducted

#### *Krushnik Effect*

Conduct a series of experiments using a static thrust stand to determine effects on thrust produced by recessing the engine into the body tube by different amounts. Body tubes (“flame-proofed”) from BT-20 on up can be used. A series of tests using one size of body tube and repeated firings of the same type of engine with different amounts of recession could be run. For greater accuracy, three readings should be made with each amount of recession. The amount of recession can be measured in centimeters, body tube diameter fractions or engine exit exhaust nozzle multiples. A multitude of different test series based on different size body tubes could be run.

#### *Static Tests*

Construct a static thrust stand to secure time-thrust curve information for comparisons of the various types of model rocket engines.

### VOCABULARY:

**Static test:** Test of a model rocket engine in a test stand. In a static test, the engine is mounted in the stand without a model rocket.

### STRATEGY:

**Materials needed:** Various model rocket engines, model rocket engine test stand, safety glasses, fire extinguisher (see section 6.1, 7.1, and 7.2 for additional materials needed).

1. Construct a model rocket engine static test stand.

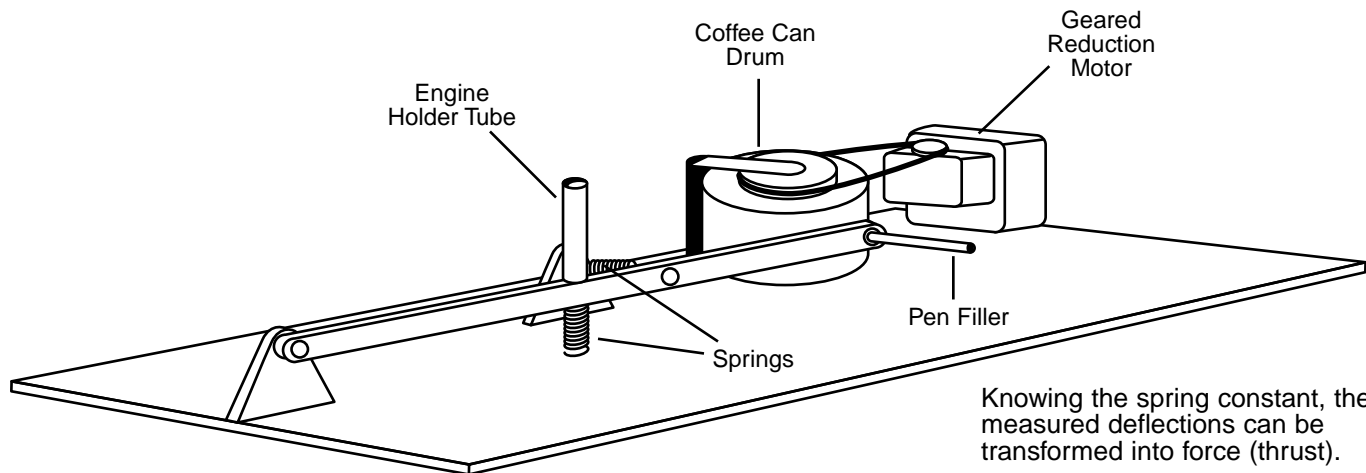

Knowing the spring constant, the measured deflections can be transformed into force (thrust).

$$\text{Spring Force} = K \times \Delta S$$

$$K = \text{Spring Constant} \left( \frac{\text{n}}{\text{m}} \right)$$

$$S = \text{Spring Stretch (m)}$$

$$\Delta = \text{Delta; change in a variable}$$

Example A

Example B

Using a strain gage glued to the surface of an aluminum bar, you can measure the strain occurring during engine combustion. This device can be wired to a computer and plotter/printer to draw the Thrust-Time Curve directly. The mechanics involved are as follows:

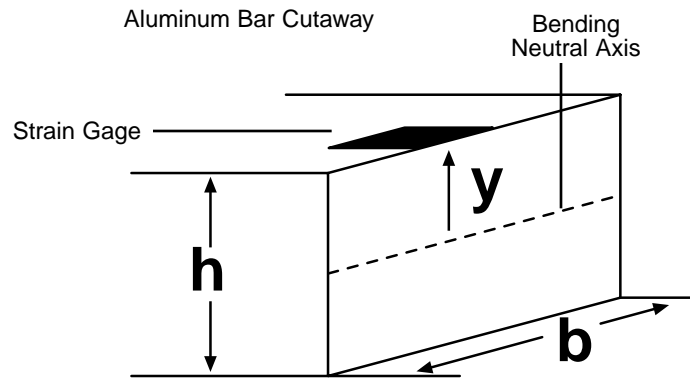
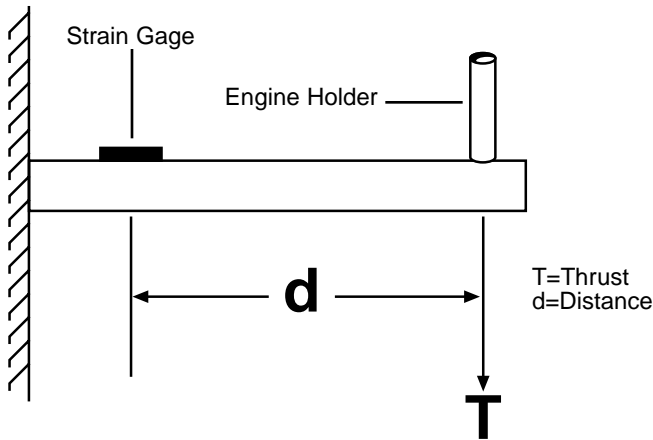

- Review the Model Rocket Safety Code (see section 6.1 of this guide), especially the sections dealing with the model rocket engine itself. Observe all Model Rocket Safety Code procedures.

$$E = \frac{\sigma}{\epsilon}$$

solve for  $\sigma$

$\sigma$  = Bending stress at surface of beam  $(\frac{N}{m^2})$

$$\sigma = \frac{My}{I}$$

solve for M

$\epsilon$  = Strain (m/m) from strain gage

$$M = Td$$

solve for T

E = Modulus of elasticity; physical material property  $(\frac{N}{m^2})$

I = Moment of inertia ( $m^4$ ) of the rectangular beam  $= \frac{bh^3}{12}$

- If you have not already done so, go over model rocket engine characteristics and model rocket engine selection (See sections 7.1 and 7.2 of this guide.)
- Have the students use the model rocket engine selection chart to choose 4-6 engines that would be suitable to test.
- Select a safe outdoor area away from combustible materials and set up the model rocket engine static test stand.
- Make sure that all students wear safety glasses.
- Test each model rocket engine.
- Collect the data (charts generated by the static test stand).
- Once the data has been collected, clean up the static test area and return to the classroom to analyze the data collected.
- Using the equations above, have the students calculate the thrust at set time intervals.
- Using graph paper (and the results of item 10) or appropriate computer software (such as a spreadsheet that will graph), have the students develop a graph that depicts the different tests.
- Discuss the results and ask the students to draw conclusions, based on the results

**CLOSURE:**

Review the conclusions drawn by the students.

**EVALUATION:**

Students should be evaluated based on the:

- Teacher made evaluation

**NOTES**

## SECTION 7

# PROPULSION

### **Activity 4 - Testing and Analyzing Performance of Model Rocket Engines**

---

**OBJECTIVES:**

By the end of this activity, the student will be able to:

- Select different model rocket engines that can be safely used to fly a specified model rocket.
- Launch and recover a model rocket using various model rocket engines.
- Gather performance data on the launches of various model rocket engines.
- Analyze the data on the launches of various model rocket engines.

**BACKGROUND FOR THE TEACHER:**

The performance of a model rocket will vary greatly by flying the rocket with different model rocket engines. One way that students can apply their knowledge of engine characteristics is to see the differences in action. In this activity, students will be asked to analyze the characteristics of the flight of a single model rocket using different model rocket engines.

**STRATEGY:**

**Materials needed for each student:** Launch Logs 7.4A and 7.4B, model rocket, various model rocket engines suitable for the selected model rocket and necessary materials and supplies for launch (See sections 6.1, 6.2, 6.3, 7.1, and 7.2 of this guide for additional materials.)

**Motivation:** Students are always excited about launching a model rocket. The successful recovery of the model rocket is a must. This will be a good opportunity to have them be sure that the recovery system is working properly.

1. If so desired, divide students into teams as described earlier in this guide. (See section 6.2 of this guide.)
2. If you have not already done so, go over the preparations for launch (See section 6.1 of this guide.)
3. If you have not already done so, go over how to track a model rocket (See section 6.3 of this guide.)

4. If you have not already done so, go over model rocket engine characteristics and model rocket engine selection (See sections 7.1 and 7.2 of this guide.)
5. Select the model rocket to be tested.
6. Have the students use the model rocket engine selection chart to choose 4-6 engines that would be suitable to launch the model rocket selected.
7. Set up the teams at the launch site.
8. Launch the model rocket with each engine and keep accurate records of the altitude and performance of the model rocket during each launch. Inspect the model rocket and make any necessary repairs between launches, being careful not to change anything that would effect the flying dynamics of the model rocket during the next launch.
9. Once the data has been collected, clean up the launch area and return to the classroom to analyze the data collected.
10. Using Launch Log 7.4A, have the students fill in all of the data.
11. Using Launch Log 7.4B or appropriate computer software (such as a spreadsheet that will graph), have the students develop a graph that depicts the different launches.
12. Discuss the results and ask the students to draw conclusions based on the results.

**CLOSURE:**

Review the conclusions drawn by the students.

**EVALUATION:**

Students should be evaluated based on the:

- Completion of Launch Log 7.4A
- Completion of Launch Log 7.4B

**EXTENSION:**

Use an electronic altimeter to gather the data on each flight. There are various electronic altimeters available from a third party vendor. Adept Rocketry has a series of electronic sensors that will record altitudes, velocity and acceleration at set time intervals of the model rocket while it is in flight. These altimeters measure in one foot increments up to 15,000 feet. Some altimeters are direct reading, whereas the recording altimeter requires computer software to download the data once the flight has been completed.

Adept Rocketry  
2545 Overlook Dr.  
Broomfield, CO 80020  
(303) 466-9605

**NOTES**



# SECTION 7

## PROPULSION

### Activity 5 - Maximizing Model Rocket Performance

---

#### OBJECTIVES:

By the end of this activity, the student will be able to:

- Safely set up a model rocket engine for launch.
- Prepare and test model rocket launch equipment.

#### BACKGROUND FOR THE TEACHER:

The setup of the model rocket for launch is critical to a successful flight. This activity will offer suggestions for the teacher to use with various other activities to help insure a successful launch.

#### STRATEGY:

**Materials needed:** Launch equipment and supplies, battery tester, VOM.

**Motivation:** Nothing is more disappointing to the student, and the teacher, when a great deal of hard work has gone into constructing a model rocket and preparing it for launch than to see it just sit on the launch pad not going anywhere. While launch delays cannot always be avoided, there are steps that can be taken to insure a greater launch success rate.

The following tasks can be assigned to students to complete or the teacher may wish to complete these him/her self.

1. Check to be sure that the launch controller is working properly. While most launch controllers have a ready indicator light, the launch controller can be checked using a VOM to insure that there is a complete circuit to the igniter.
2. If a handheld launch controller has been sitting around for a period of time with batteries in it, the circuitry could be corroded and/or the battery may be dead. Unless a launch controller is going to be used frequently, remove the batteries after launch. Check the battery compartment for corrosion. If corrosion is found, use some fine grit sandpaper to remove it. Unless the battery is known to be good, use a battery tester to test the battery. It would be a good idea to have spare batteries on hand.
3. Check the wiring from the launch controller to the launch pad to be sure that there are no frays or areas that have been burned by previous launches. Use the VOM to be sure that the current will flow.
4. The micro-clips or alligator clips that are used to connect the launch wire to the igniter are under a great deal of heat at launch and easily become corroded. To help insure a successful launch, these clips should be cleaned regularly with sandpaper or emery paper.
5. A frequent ignition failure can be the improper installation of the igniter. The set up of the model rocket engine for launch should be double checked to insure that the igniter leads do not short out, that the igniter is installed completely into the nozzle throat (making contact with the propellant), igniter plug inserted fully before bending the igniter wires and that the micro-clips or alligator clips

are making full contact with the leads on the igniter (but not shorting out). In addition, great care should be taken to be sure that the micro-clips or alligator clips do not short out on the launch rod or the blast deflector.

**CLOSURE:**

Review each step mentioned above for each launch.

**EVALUATION:**

Students should be evaluated based on the:

- A delay free launch

**NOTES**

# SECTION 8

## ELECTRONICS

### Activity 1 - Launch Equipment Circuitry

---

#### OBJECTIVES:

By the end of this activity, the student will be able to:

- Draw a schematic of a standard electrical launcher.
- Draw a pictorial of a standard electrical launcher.
- Assemble a standard electrical launcher.
- Test a standard electrical launcher.

#### BACKGROUND FOR THE TEACHER:

The model rocket launching system is designed to safely and efficiently hold the model rocket prior to launch and to provide an electrical charge to the igniter. The electrical launcher is designed to use a safety key that will prevent a premature or uncommanded launch. This activity is designed to acquaint the student with the electrical components of the launching system. The activity can be completed by students who have had an introduction to electricity or electronics. For those students with no prior electricity or electronic background, you will need to spend some additional time introducing them to simple series and parallel circuits, components and electrical measurement. In the design of a launch control system, it is important to remember that only 1 ampere of current is required to ignite an Estes igniter. The resistance in the continuity light and wires must be high enough to prevent ignition until the launch switch is activated. Estes publication “Model Rocket Launch Systems Guide” offers a very comprehensive look at the electrical launch control system and makes a good resource guide for this activity.

#### VOCABULARY:

**Ampere (Amp):** The unit used in measuring the strength of an electrical current; an ampere is equal to the steady current produced by one volt applied across the resistance of one ohm.

**Circuit:** The complete path of an electric current including the source of electricity.

**Conductor:** A material that allows for the flow of electrons.

**Current:** The movement of electricity or rate of electrical flow; measured in amperes.

**Insulator:** A material that resists the flow of electrons.

**Ohms:** Unit of electrical measurement, measuring resistance; one ohm is equal to the resistance of a circuit in which a potential difference of one volt produces a current of one ampere.

**Pictorial:** A three dimensional drawing that shows an accurate representation of the size, shape and type of object.

**Safety key:** A special interlock key used to activate a launch system.

**Schematic:** A drawing of an electronic circuit that shows the circuit and the components; a schematic uses symbols to designate the electronic components.

**Volt:** The unit of electromotive force; the electrical potential required to make a current of one ampere flow through a resistance of one ohm.

#### STRATEGY:

**Materials needed for each team:** Launch Logs 8.1A and 8.1B, and TR 8.1, disassembled electrical launcher, tools necessary to assemble the launcher and a VOM,.

**Motivation:** Students are often inspired when studying about electricity, especially when the study involves assembling an electronic circuit. This activity will also help the students to better understand a launch delay due to an electrical malfunction.

1. If so desired, organize students into teams. Discuss the importance of teamwork and coordination.
2. Using TR 8.1A, present the students with both a pictorial view and schematic of an electrical launch system.
3. On Launch Log 8.1A, have the students draw a pictorial view and schematic of an electrical launch system.
4. Give each team a disassembled electrical launcher. Using the drawings that they just made, have them assemble the launcher.
5. Once the launcher has been assembled, check over their work for neatness and accuracy.
6. Using the VOM, have the teams test the launcher.

7. Have students complete the crossword puzzle, Launch Log 8.1B.

Optional: Using the examples in the “Model Rocket Launch Systems Guide” have the teams discuss and answer each problem 1-7.

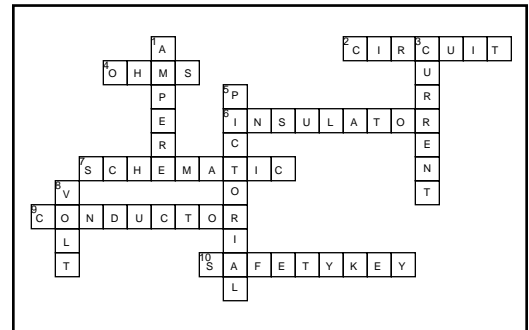

### **CLOSURE:**

Review the terms important to electricity and electronics that are relevant to the study of the model rocket launch system. Have each team present their completed electrical launchers.

### **EVALUATION:**

Students should be evaluated based on the:

- Completion of Launch Log 8.1A
- Completion of Launch Log 8.1B
- Successful assembly of the launch system

### **NOTES**

# SECTION 8

## ELECTRONICS

### Activity 2 - Designing a Multiple Rocket Launch Console

---

#### OBJECTIVES:

By the end of this activity, the student will be able to:

- Draw a schematic of a multiple electrical launch console.
- Generate a parts list for a multiple electrical launch console.
- Develop a cost estimate for a multiple electrical launch console.
- Assemble a multiple electrical launch console.
- Test a multiple electrical launch console.

#### BACKGROUND FOR THE TEACHER:

A launcher with several launch pads is a convenient device for flying many model rockets in rapid succession. A multi-pad system may provide a number of launcher set-ups (adjustable rods or rails, blast deflector plates and micro-clip connectors) attached to one power supply and control unit.

The electrical power supply to the micro-clips is usually a separate wire to each launch pad to carry the electrical current to that pad and a common (shared) return or “ground” wire.

The control panel for a multiple launcher usually incorporates a key-operated power supply switch (to turn the power supply off and on), a power supply pilot bulb (to indicate when the power supply is on), a rotary selector switch (to direct the current only to the pad in use), a continuity light (to indicate if the electrical current through the igniter is complete) and a launch switch.

#### STRATEGY:

**Materials needed for each student:** Launch Logs 8.2A, 8.2B, 8.2C, TR 8.2A, TR 8.2B, materials to be decided upon by the instructor and the students, tools necessary to assemble the launcher and a VOM.

**Motivation:** A multiple launcher can easily be built. It is a very handy device for contests and demonstration launches. If the students have a hand in designing and constructing the multiple launcher, they will have a vested interest in every flight that takes place. In developing the multiple launcher system, the students will be asked to develop a materials list and a cost estimate. The cost estimate can be generated either on paper or by using a computer spreadsheet.

1. If so desired, set up students into teams. Discuss the importance of teamwork and coordination.
2. Using TR 8.2A and TR 8.2B, present the students with a schematic of a multiple electrical launch system.
3. On Launch Log 8.2A, have the students draw a schematic of a multiple electrical launch system.
4. Supply each student with Launch Log 8.2B. Have each student complete Launch Log 8.2B.

5. Once the bill of materials has been completed (Launch Log 8.2B), hand out Launch Log 8.2C and a catalog from an electronics supply house. Have the class determine the total number of multiple launcher systems that need to be built. Based on the number of multiple launcher systems that need to be built, have each student prepare an estimate of the cost of the materials needed to complete the activity.
6. Gather all of the materials needed to complete the activity.
7. Instruct the students on how to safely use any tools and machines necessary to complete the activity.
8. Using the drawings that they made, have them assemble the multiple launcher.
9. Once the multiple launcher has been assembled, check over their work for neatness and accuracy.
10. Using the VOM, have the teams test the launcher.

**CLOSURE:**

Review the schematic diagram and discuss how it delivers the current only to the launch pad desired.

**EVALUATION:**

Students should be evaluated based on the:

- Completion of Launch Log 8.2A
- Completion of Launch Log 8.2B
- Completion of Launch Log 8.2C
- Successful assembly of the launch system

**NOTES**

# SECTION 9

## COMMUNICATIONS APPLICATIONS

### Activity 1 - Mission Logo

---

#### OBJECTIVES:

By the end of this activity, the student will be able to:

- Make thumbnail sketches of mission logo/patch ideas.
- Make rough sketches of mission logo/patch ideas.
- Develop a final layout of the mission logo/patch.
- Print the mission logo/patch.

#### BACKGROUND FOR THE TEACHER:

All missions for NASA have a mission patch. This mission patch is basically a graphic logo. The logo will generally depict some important aspect of the mission and be used as a way of identifying the mission and making it unique. Manned missions also include the names of the astronauts on the logo. The logo is generally round but other shapes have been used. Once a mission has been completed, a history of the mission can be included whenever the logo is distributed. Once designed, these logos can be used as a mission patch, decal, letterhead logo, T-shirt design, hat patch, etc.

#### VOCABULARY:

**Font:** The style of letters used in a graphic project.

**Layout:** The process of setting up how something to be printed is to be arranged.

**Logo:** A graphic design that is unique to a specific item, company, agency, etc.

**Rough Sketch:** A freehand drawing that outlines the basic idea of how something to be printed is to be setup.

**Thumbnail:** A very small, preliminary sketch; thumbnails are generally used to explore many different possibilities; they are a way of graphically brainstorming.

#### STRATEGY:

**Materials needed for each student:** Samples of mission patches, TR 9.1, Launch Logs 9.1A - 9.1C, graphic computer software (optional), printing supplies as decided upon by the class.

**Motivation:** The mission logo is unique to each individual mission. The design of the logo should incorporate the basic purpose of the mission and identify the mission by name or some other designation. This is a tool by which the public (others in the school) can identify your model rocket project and thus will be attributed to you.

1. If so desired, set up students into teams and/or sub-teams. Discuss the importance of teamwork and coordination.
2. Have the class or each team decide how they want to print the final design of their mission logo. One idea would be to have each team screen print their logo onto mission shirts. Another idea would be to create a large mission banner.
3. Show examples of any logos or mission patches that you may have and use TR9.1.
4. Discuss with the class some of the important concepts that need to be included in the logo.

5. Have each student draw several thumbnail sketches using Launch Log 9.1A to develop some basic ideas of what the logo could look like.
6. Using Launch Log 9.1B, have each team develop several rough sketches of the better logo ideas.
7. Using Launch Log 9.1C or an appropriate graphic based computer program, have each team develop a final layout of their best logo idea. This layout should also include details such as colors, font and font size.
8. Using proper printing techniques, have each team print their mission logo.
9. Set up a display of mission logos that each class developed.

#### **CLOSURE:**

Review the importance of and the reasons for having a mission logo. Have each team describe their mission logo and tell what significant features it includes. Mission logos could be entered into a contest and the student body can vote on the best ones.

#### **EVALUATION:**

Students should be evaluated based on the:

- Completion of thumbnail sketches
- Completion of rough sketches
- Completion of graphic layout
- Final printed logo

#### **EXTENSION:**

If there is a local embroidery shop in the area and your class has designed a graphic logo for the entire project, try to arrange to have a patch made of the logo. A visit to the embroidery shop can be educational because many shops now employ the use of CNC machinery to create their patches.

#### Notes

## **SECTION 9 COMMUNICATIONS APPLICATIONS**

### **Activity 2 - Press Kit**

---

#### **OBJECTIVES:**

By the end of this activity, the student will be able to:

- Create a data base of local press.
- Write a press kit that describes your model rocket project.
- Contact the local press and invite them to your model rocket event.
- Follow-up press visits with a letter of appreciation.



## **BACKGROUND FOR THE TEACHER:**

The importance of good public relations can not be over stressed. The community is always interested in what the schools are doing and a model rocket project is a very visible, exciting way to catch the public's interest. The press kit is a medium for getting information into the media in a way that is similar to the office of Public Affairs at NASA. The press kit should include a cover page (with the mission logo), a listing of public affairs contacts, a general narrative description of the project or mission, a quick overview in outline form, a timeline and any important specifications.

Be sure to follow any press release guidelines that your school or district has set. If you have a public relations contact in the school or district, you should discuss this project with him/her first.

## **VOCABULARY:**

**Press kit:** A package that is designed to state the facts and other important information about a specific mission or project.

**Press/Media:** A term used to describe those who gather and publish news and other important information to the public.

## **STRATEGY:**

**Materials needed for each student:** Local phonebooks, index cards or computer data base software, envelopes, address labels, school or mission letterhead, and paper.

**Motivation:** Students generally like to see their names in print. They also like to see successful projects at their school published, especially if they are directly involved in the project. Students need to understand the importance of getting the correct information in the hands of the press/media. They also need to be aware that while it is a main goal of the press/media to report accurately, that does not always occur. They need to be prepared for possible inaccurate reports of their project.

1. If so desired, set up students into teams and/or sub-teams. Discuss the importance of teamwork and coordination.
2. Discuss with the class the importance of good public relations.
3. Have the class generate a list of all of the media/press in the local area. Don't forget to include the small, weekly publications and larger regional magazines. If your model rocket event is a big, spectacular one, go all out and include national press/media, such as CNN.
4. Assign each team several media/press agencies and have them research the address and phone number for each one.
5. Using a series of index cards or a computer program, develop a media/press data base.
6. Assign each team a section of the press kit. These sections include:
  - A cover page (with the mission logo)
  - A listing of public affairs contacts (including the mission teams)
  - A general narrative description of the project or mission
  - A quick overview in outline form
  - A timeline
  - Important specifications

7. Have one team write a cover letter to invite the press/media to your model rocket event.
8. Have each team research their area and write no more than a page.
9. Once the teams have written their section of the press kit, put all of the sections together and make copies.
10. Have the teams use the data base of press/media agencies in your area to generate mailing labels.
11. Package the press release kits and mail them well in advance of the event.
12. After the event has finished, have students write a letter of appreciation to any press/media who attended even if they did not run a story. A mission/event letterhead can be set up to send this letter on.
13. Put the press kits that each class developed on display.

**CLOSURE:**

Review the importance of good public relations and how it affects the motivation of those involved in a project. Have each team present their portion of the press kit. Go over the press kit that other classes developed.

**EVALUATION:**

Students should be evaluated based on the:

- Completion of their portion of the data base
- Completion of their portion of the press kit

**NOTES**

# SECTION 9

## COMMUNICATIONS APPLICATIONS

### Activity 3 - Newsletter

---

#### OBJECTIVES:

By the end of this activity, the student will be able to:

- Write newspaper articles to describe your model rocket activities.
- Generate a newsletter that includes a banner, graphics and stories related to your classes model rocketry activities.
- Distribute the newsletter to other students in the school.

#### BACKGROUND FOR THE TEACHER:

Desktop publishing has become an important tool in the information age. What better way to excite your students that to have them create a newsletter that either describes upcoming model rocket events or reports on past model rocket events.

#### VOCABULARY:

**Banner:** The top portion of a newsletter that usually includes the name of the newsletter.

**Graphic:** A group of symbols that are put together to create a design.

**Graphic element:** The smallest unit of a graphic design; a line is an example of a graphic element..

**Newsletter:** A printed document that informs a predetermined audience about important information; it generally includes a banner, graphics and text.

#### STRATEGY:

**Materials needed:** Appropriate desk top publishing software.

**Motivation:** Students enjoy telling stories to others. Using a desktop publishing program to tell others about a model rocket project is a motivating way to allow students to learn more about a technology while improving their writing skills. A completed newsletter can be used to tell about club activities and give the students something to be proud of.

1. If so desired, set up students into teams and/or sub-teams. Discuss the importance of teamwork and coordination.
2. Have each team decide upon an editor for their newsletter. The editor should then assign different students to different aspects of the newsletter. Students should be assigned to each of the following areas:
  - Layout
  - Reporting and writing
  - Graphic production
3. The team should use standard desk top publishing techniques throughout this process. They should work together with the editor to coordinate stories and graphics with the layout.
4. Once the newsletter has been completed and proofed, a master should be printed.
5. The master should be duplicated and distributed to the target audience.

**CLOSURE:**

Review the importance of good public relations and how a good newsletter can provide information to keep a target audience up to date on a specific topic. Show examples of newsletters that other classes or teams have developed and discuss them.

**EVALUATION:**

Students should be evaluated based on the:

- Completed newsletter

Notes

## SECTION 9

# COMMUNICATIONS APPLICATIONS

### Activity 4 - Launch/Recovery Credentials

---

**OBJECTIVES:**

By the end of this activity, the student will be able to:

- Develop a criterion for launch/recovery security credentials.
- Develop a list of individuals who will need launch and recovery site clearance.
- Create launch/recovery security credentials.
- Laminate the launch/recovery security credentials.
- Establish and maintain a launch/recovery security team.

**BACKGROUND FOR THE TEACHER:**

The security of the launch area is of the utmost importance. Whenever you have a launch that is surrounded by large groups of spectators, security becomes a problem. By setting up specific guidelines and including your students as an integrated part of the launch security, you can impress upon your students and spectators the importance of having a secure launch site. You can involve as many different student groups as you wish to set up security. If you have a Junior ROTC unit at your school or nearby school, you could enlist their help in acting as uniformed security. Your local Civil Air Patrol unit or Boy Scout Troop could also help in this matter.

**VOCABULARY:**

**Credential:** A document that offers specific information about an individual including levels of clearance

**Laminate:** The covering of a document with a protective plastic covering.

**Security team:** A group of individuals working together to provide a secure environment.

**STRATEGY:**

**Materials needed:** TR9.4.

**Materials needed for each student:** Samples of security credentials (gathered by the teacher), appropriate graphic software, laminating materials, laminating equipment, clip or necklace to hang credentials from, handheld or headset walkie talkies (optional).

**Motivation:** Students love to be able to tell others what to do. This activity will give a few students just that opportunity. By setting up a launch security team, you will involve students in an aspect of real life that can be very exciting. The launch security team can be created by using students who are not going to be directly involved in the launch and recovery of the model rockets on launch day.

1. Discuss the need for security at NASA launch and recovery sites. Not only is security important to the safety of the vehicle, it also is important to the crew, launch/recovery teams, launch site and spectators.
2. Discuss the use of credentials and show examples of several that you have collected.
3. Have students list things that are important to be included on a launch/recovery credential. From this list, set up different levels or zones of clearance.
4. From the mission teams that have been established for launch and recovery (see section 6.2 of this guide), have students identify individuals who need launch or recovery clearance. Establish what level or zone they will need clearance for and don't forget that the security team will also need credentials.
5. Use TR9.4 as an example of a security credential. Have students use a graphic computer program if available (if a program is not available, this activity can be completed on a heavy stock paper with pens) to develop the credential. You may wish to develop a "GOLD PASS" that will give the holder unlimited access to all secure areas for emergency purposes.
6. Once the credential has been designed, make the necessary number of copies.
7. Laminate the credentials and attach a clip or other type of device to be able to hang the credential from a shirt or from around the neck.
8. Establish check points around the launch and recovery areas.
9. Instruct the security team to not allow individuals beyond the check points without proper security clearance and establish procedures for dealing with rebellious individuals.
10. Be sure that the security team is in place well before the anticipated launch time and has adequate means of communicating with each other if necessary. Small handheld or headset walkie talkies are ideal for this purpose.

### **CLOSURE:**

Review the importance of security for both launch and recovery sites. Have students check to make sure that their credential offers them the correct clearance. It would be a shame for your launch director not to have access to the launch site.

### **EVALUATION:**

Students should be evaluated based on the:

- Completed launch/recovery security credentials
- Maintenance of secure launch and recover sites

**EXTENSION:**

As an extension to this activity, the class can develop a badge with the school logo (center) for all participants. This center badge can then be used for all missions launched from the school.

Notes

## SECTION 9

# COMMUNICATIONS APPLICATIONS

### Activity 5 - Space Link

---

**OBJECTIVES:**

By the end of this activity, the student will be able to:

- Describe the benefits of Space Link.
- Log on to Space Link.
- Research space history on Space Link.
- Research a present or upcoming mission on Space Link.

**BACKGROUND FOR THE TEACHER:**

**(This background comes directly from NASA's Spacelink.)**

NASA Spacelink is an electronic information system available for use by the entire educational community. The Education Division at NASA Headquarters has overall cognizance for Spacelink, and has assigned the development and operation of the program to the Marshall Space Flight Center (MSFC).

NASA Spacelink offers a wide range of materials (computer text files, software, and graphics) related to the space program. Its target audience is teachers, faculty and students and the system is intended to help them reach the national education goals as outlined by the President and the NASA Strategic Plan for Education. Documents on the system include science, math, engineering and technology education lesson plans, historical information related to the space program, current status reports on NASA projects, news releases, information on NASA educational programs, NASA educational publications and other materials chosen for their educational value and relevance to the space program. The system may be accessed by computer through direct-dial modem or the Internet. Materials on the system are organized and kept current by professional educators with experience in computer software applications and communications.

NASA Spacelink was first made available to the public in February, 1988. At that time the system ran on a Data General MV7800 minicomputer and could handle eight simultaneous calls via 2400 baud modems. The system received about 500 calls during its first month of operation. System usage grew steadily through the end of the decade as a wider variety of documents, faster modems and other features were added. In 1991 Spacelink was configured to accept Telnet calls via Internet. As the rate of connections soared to more than 1,000 calls per day, system performance was affected. By early 1993, it became clear that a new system was needed to serve the growing numbers of educators and students who were beginning to utilize the high-speed communications and other enhanced features offered by the Internet. In response, NASA has developed this second-generation Spacelink, which replaced the old system in September 1994. We plan for the new system to continue to offer helpful educational materials to educators and students as it grows in usage and expands in features.

NASA Spacelink is a dynamic system that will change and expand daily. Major funding for the program has been provided by the Education Division at NASA Headquarters. The NASA Spacelink data base is maintained by the Education Programs Office at the NASA Marshall Space Flight Center in Huntsville, Alabama. Operational support is provided by the Information Systems Office at the Marshall Center. Information on NASA scientific projects and educational programs is provided to NASA Spacelink by education specialists at NASA Headquarters and the NASA field centers.

While NASA understands that people from a wide variety of backgrounds will use NASA Spacelink, the system is specifically designed for educators. The data base is arranged to provide easy access to current and historical information on NASA aeronautics and space research. Also included are suggested classroom activities that incorporate information on NASA projects to teach a number of scientific principles.

## VOCABULARY:

- Bulletin board:** A place on an online service where users post messages and responses; a bulletin board is generally open for the public to read.
- Download:** The process of retrieving computer software or files through an online service and saving them to your disk drive.
- E-Mail:** Electronic mail that is sent by a computer through the phonedlines to another user or users.
- Internet:** A web of telecommunication computer networks that are linked together to allow the user to access information from anywhere in the world.
- Modem:** (modulator demodulator) The device that connects the computer and the phone system together and allows them to interface. If two computers are going to “talk” over the phone line, then each is required to have a modem.
- Online Service:** A commercial service that allows the user to connect via computer to access information, share software files, send and receive e-mail, post on a bulletin board and other services specific to specific services.
- Online:** The term used to describe connecting with another computer through a modem and phone line.
- Telecommunications:** The method of communicating over long distances; using telephone lines and computers equipped with modems is one form of telecommunications.

## STRATEGY:

**Materials needed:** Launch Log 9.5, a computer with telecommunications capabilities (including software) and a computer projection device (if available) for a full class demonstration.

1. Many students use telecommunications at home to conduct research for reports or to communicate with friends. Ask the students to tell about any telecommunications experience that they have had.
2. Discuss the vocabulary terms and describe how Spacelink works (see the background for the teacher).

3. Have the students complete Launch Log 9.5.

4. Log on to Space link.

- Spacelink may be accessed at the following address:  
<http://www.spacelink.nasa.gov>
- The NASA Education Home Page is  
<http://www.hq.nasa.gov/education>

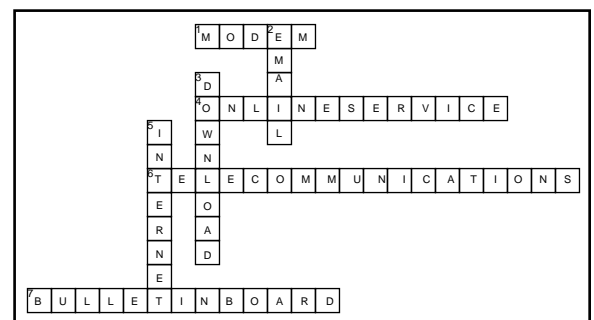

5. Have the students do research on Spacelink into NASA history, a current mission or an upcoming mission.
6. Students should either download or print their findings.
7. Have students make a classroom presentation that tells what they found online.

**CLOSURE:**

Review how Spacelink works and how it is related to other online services and the Internet. Discuss any problems associated with signing on, downloading or printing the information found online. Review the types of information that the students found online and make a display that shows examples of that information.

**EVALUATION:**

Students should be evaluated based on the:

- Completion of Launch Log 9.5
- The presentation of the research downloaded or printed

**EXTENSION:**

Educators can learn about new NASA Educational Products by subscribing to Spacelink EXPRESS. Spacelink EXPRESS is an electronic mailing list that informs subscribers quickly by e-mail when new NASA educational publications become available on Spacelink. To join the NASA Spacelink EXPRESS mailing list to receive announcements of new NASA materials and opportunities for educators, access this address: <http://spacelink.nasa.gov/xh/express.html>

## SECTION 9

# COMMUNICATIONS APPLICATIONS

### **Activity 6 - Technical Report**

---

**OBJECTIVES:**

By the end of this activity, the student will be able to:

- Develop a list of possible topics for a technical report.
- Choose a topic for a technical report.
- Write a technical report on the topic chosen.

**BACKGROUND FOR THE TEACHER:**

Written communications is one aspect of industrial work that is extremely important. Industry is concerned with the worker's ability to communicate effectively. The technical report is one way that industrial workers communicate with each other, with engineers and with management. Work in conjunction with English teachers in your school to insure that the students follow similar formats that they do in other classes throughout the school.



**VOCABULARY:**

**Technical Report:** A report written that describes a technical topic or summarizes a technical activity like a static rocket test or a model rocket launch.

**STRATEGY:**

**Materials needed for each student:** Resource materials (available from your media center, NASA, and Spacelink in addition to other sources), computer with a word processing program.

1. Discuss the format that you want the students to use for their technical report.
2. Have students brainstorm on possible topics for their technical report.
3. Students should choose a topic for their technical report.
4. Using the resources available, have students research their chosen topic.
5. Have students outline their report.
6. Have students write a rough draft of their technical report.
7. Each student should trade their draft reports with another student in the class and read the report. Have the students get together and discuss the report.
8. Students should then edit the report and print final copies.
9. If you desire, class presentations may be made.

**CLOSURE:**

Review the importance of effective communication in the workplace. Discuss the variety of topics that different students reported on. Discuss the technical reports that were written by other classes.

**EVALUATION:**

Students should be evaluated based on the:

- Completed technical report

Notes

# SECTION 9

## COMMUNICATIONS APPLICATIONS

### Activity 7 - Aerial Photography

---

#### OBJECTIVES:

By the end of this activity, the student will be able to:

- Construct and launch an Astrocam® 110.
- Use basic photo interpretation techniques to calculate the altitude of a rocket.
- Use basic photo interpretation techniques to determine the size of various objects on the ground.
- Make a map of an area photographed using the Astrocam® 110.
- Use the Astrocam® 110 to simulate a military reconnaissance mission.

**BACKGROUND FOR THE TEACHER:** Reprinted from Estes Educator News, Vol 19, No. 19, Winter 1993, "Aerial Photography" by Bill Dennett.

Taking aerial photographs is fun. Interpreting those photos to learn what they can reveal is a very rewarding project. Surprisingly, even students in the fifth or sixth grades can accomplish these goals with a little guidance from you.

The Astrocam® 110 is a small, simply assembled aerial camera that is launched on top of a model rocket to take a single photo per flight from about 500 feet altitude. The photo is taken at the instant of parachute ejection by a simple mechanism. The photo is taken "looking forward", and to get vertical photos, an extra long delay is used in the rocket engine so the rocket reaches apogee, then turns nose down for a second or so before ejection. When the rocket is recovered, the film is advanced to the next frame, the rocket is prepped with a new engine and recovery wadding, and it's ready to fly again.

The camera uses readily available 110 film cartridges, 200 ASA, and the processing is available locally. The low cost of the Astrocam®110 kit (camera and rocket for \$31.99 suggested retail) plus the ease of obtaining

film and processing, mean that an aerial photography project is well within reach for the average classroom or individual modeler.

The Astrocam® 110 is a natural for learning the basics of photo interpretation. Students can take several shots of the

schoolyard or other flying area, then study the "bird's eye view" prints to learn what they can about the area. Then, they can make a manual survey of the same area to confirm or further analyze their initial findings - this is known as groundtruthing.



Aerial photos give students a perspective of an area often unobtainable any other way. They may be surprised to see details of a familiar area never before apparent to them. With several in flight shots, taken from slightly different vantage points, it is possible to create a montage showing a much larger area than one photo can.

Here's an exercise that gets a few laughs but illustrates the point. Have your students look around the classroom for a

few seconds, then have them stand on something that gives them a "high altitude" perspective - a tall chair, their desk, or (heaven forbid) your desk. It's obvious that the view will be different, but find out if they can see any details that weren't apparent before, like dust on top of ledges or bookshelves. Another example is to have them lie down on the floor - here they may see gum on the bottoms of the chair. While neither of those observations would be considered earth-shattering, the point is that they never normally see these things.

Why not have your students predict five things they may see from an aerial photo of the school and yard?

An interesting exercise in basic photo interpretation is to calculate the height of the rocket. To

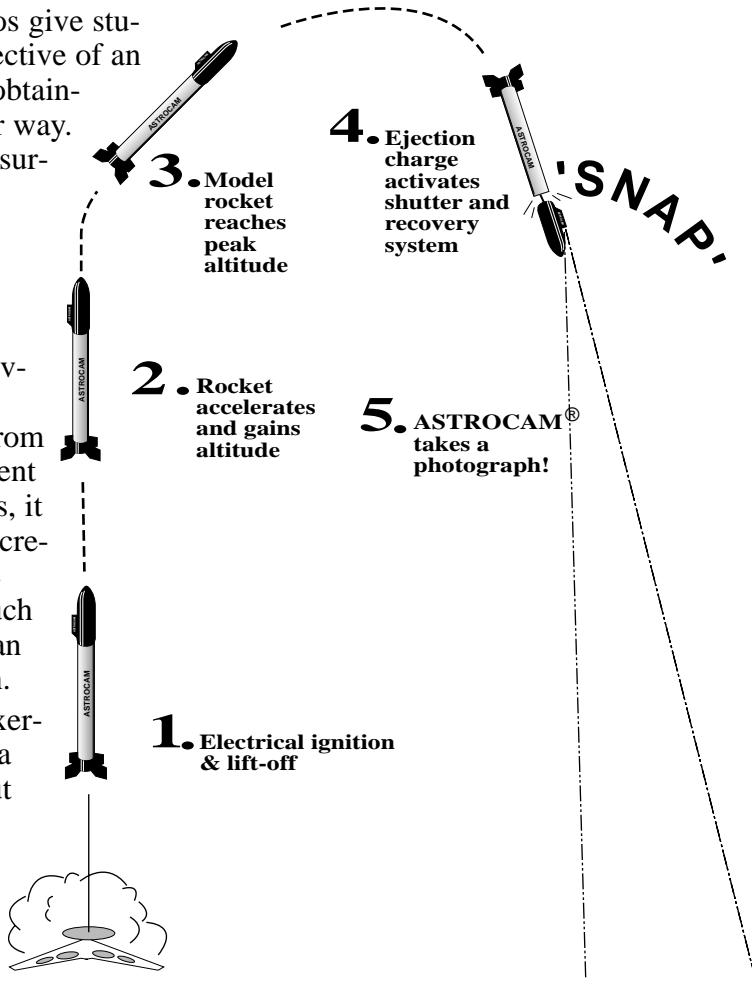

do this, compare the size of the image on the negative to the size of a known object. Then, knowing the focal length of the camera lens, you can determine the height. The height of the rocket will equal the ratio of the object size to the image size times the focal length of the lens. This system is only accurate for photos taken vertically or very near vertically.

If you are working from a print instead of the negative, you can still calculate the height, but you must know the enlargement factor of the print. Your photo processor should be able to tell you this.

The formula for calculating height this way is as follows:

- H = vertical height of camera above object
- O = object size
- I = image size on negative or

print

F = effective focal length of lens

N = enlargement factor of image on print or negative (if applicable)

$$H = \frac{O \times F \times N}{I}$$

The focal length of a lens is the distance between the focused image on the negative, and an imaginary point (the nodal point) where the light rays entering the lens cross. Sometimes this point is in the lens, sometimes it is ahead or behind the lens, depending on the design. The following illustration should clarify the relationship between image size and object size. (Figure 1)

The Astrocam's® flange focal length (1.0155") is measured from the lens flange to the negative. The thickness of the lens is 0.1113". The effective focal length is 1.1966" (30.394 mm). This places the nodal point just past the lens as shown.

Back to our exercise!

In the photo in the upper right (my thanks to Art Nestor for the print) we can see two known objects - the car and the concrete bumpers. The car, a Chevy Celebrity, is 4783mm long and 1760mm wide according to the owner's manual. The print, 4" x 6" in dimensions, has been enlarged a factor of \_\_\_\_ times from the negative.

$$O = 4783\text{mm}$$

$$N = \underline{\hspace{2cm}}$$

We already know the focal length for the Astrocam® is 30.39mm.

$$F = 30.39\text{mm}$$

The car appears 53mm long in the print.

$$I = 53\text{mm}$$

Substituting these values in our formula, we get:

$$H = O \times F \times N$$

$$= 4783\text{mm} \times 30.39\text{mm} \times$$

---

$$53\text{mm}$$

$$= \text{_____mm}$$

$$= \text{_____mm} (\text{_____ft})$$

By the way, the above photo was taken with one of Art's two-stage "lookdown" cameras (see construction article), right at the instant of staging. Interesting stuff!

If you can track the Astrocams<sup>®</sup> flight with an Altitrak<sup>™</sup> altitude measuring device, then you can calculate the size of objects in the negative or photo much the

same way by transposing the original formula:

$$O = H \times I$$

$$F \times N$$

Just a few of the things that your students can do with Astrocams<sup>®</sup> aerial photos are:

- launch from a football field - there's plenty of known object lengths for practice in altitude calculation.
- study air or water pollution sources and their effects on the immediate area.
- look for patterns in animal burrows or ant colonies.

Determine if the population



density of these habitations will reveal other factors about the area.

- Generate a map or composite photo image of the entire school yard or launch site. Compare this to an actual topographical map of the area.

Finally, here's an exercise in aerial reconnaissance/photo interpretation I thought would be fun and fairly easy to implement. Divide students into teams. Two teams are needed for each exercise, and the teams can switch roles in the same day so everybody gets a chance to launch.

Equipment needed:

- Astrocams<sup>®</sup> camera and rocket, C6-7 engines and launch accessories.

- Altitrak<sup>™</sup> or other altitude measuring device. See the Spring '93 issue of Estes Educator<sup>™</sup> News for information on two station tracking. This gives very accurate measurements.

- Chalk line marker, bright colored marking ribbon, or any other method of creating the "secret enemy headquarters" in a visible manner on the launch field.

- A football field or baseball

#1

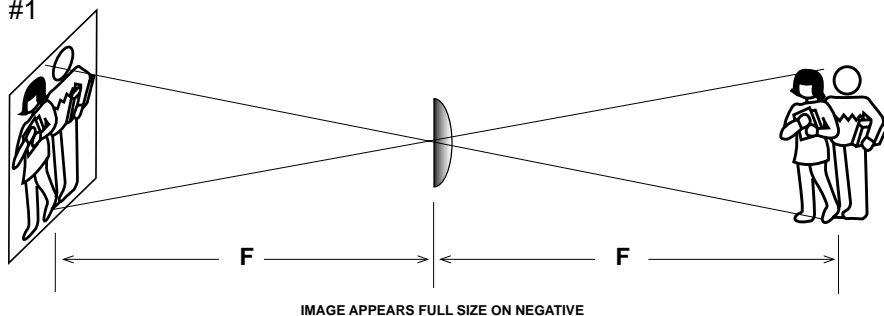

#2

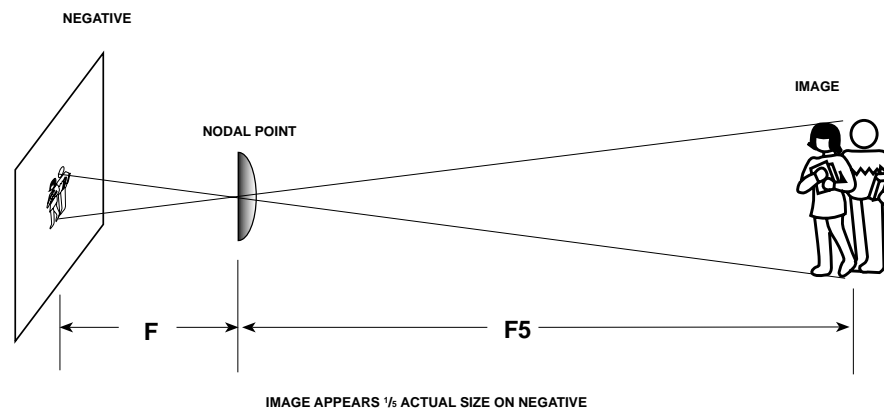

#3

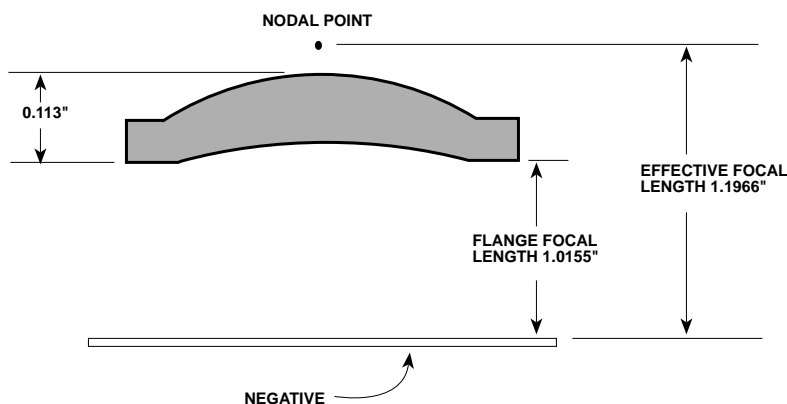

diamond works well for this, with the close cropped grass, but any launch site can be used with some imagination.

Team one now creates the secret headquarters by marking out a simple building (square or rectangle) on the field. They should measure and

record all the dimensions, and if possible measure the distance from landmarks that will likely appear in the photo, such as goalposts, yard or base lines, or buildings. They will keep this information "secret" until team two has completed their work.

Team two is the photo reconnaissance team. Their goal is to capture the secret facility in their aerial photos, then analyze those photos to determine the size of the building, and its location relative to known objects and landmarks. They can use

the formula given earlier to determine these values.

Several shots will probably be needed to ensure that useable photos of the "secret facility" are made. Normal size or 4x6 prints should be adequate for interpretation. Have fun!

For information on the Astrocam® 110 aerial camera, visit your local hobby shop, and/or write to Estes Industries, Customer Service Department, for a free catalog.

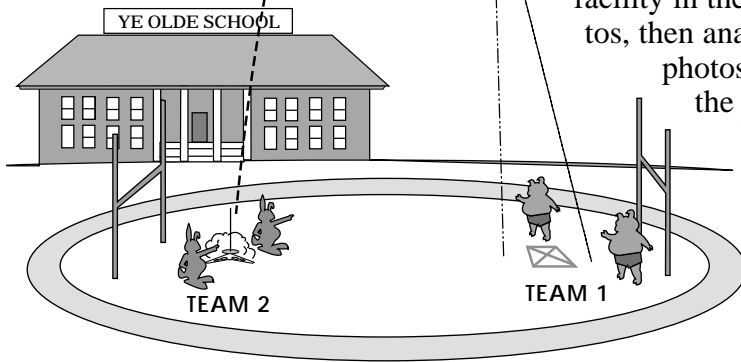

### STRATEGY:

**Materials needed:** NASA satellite images, Astrocam® , package of 110 film (ASA200), Altitrak™, launch equipment, Launch Log 9.7, and scale.

1. Discuss the concept of aerial photography and photographic interpretation. You can get some satellite images from NASA and use them for your classroom discussions.
2. Students should follow the general guidelines found in section 4.1 and the Astrocam® directions to construct the rocket.
3. Load the Astrocam® with film and make several flights to shoot the roll of film. For several of the flights, have a selected group of students hide a large model rocket or model aircraft or model airport in a remote area. Be sure the rocket will do several flybys of the area where they are hiding. This can be used to simulate military reconnaissance.
4. Using the concepts of tracking found in section 6.3, track each rocket flight and keep a record of these flights in Launch Log 9.7.
5. If you have a color darkroom available, have the students develop the film and make their prints. If no darkroom is available, have the film developed locally.
6. Using the concepts described in the background for the teacher section, have the students select several photographs, choose some specific items in the photograph and determine the size of each item. They will need to use the information from Launch Log 9.7 to determine this.

7. Students can take the size of a known object in the photograph and the scale of the print to determine the altitude of the rocket for a specific launch. Have them cross check this calculated altitude with the altitude determined from Launch Log 9.7.
8. If the photographs were all taken of one area, they can be assembled in a collage. A map can then be generated by the class that shows details of buildings, walks and other objects. By using the photo interpretation techniques described earlier, a scale for the map can be determined.
9. Have the class make a display of the photographs and maps that they have created.
10. Take the “military reconnaissance” photographs and enlarge them to show details of the “enemy” installation. Have students develop a briefing that describes what they have seen in the photos and report it to the class. These photos could be put into a display with labels marking the “enemy” installation.

### **CLOSURE:**

Review the basic uses of photo interpretation and how to determine the scale of objects in aerial photographs. This would be a good time to talk about aerial maps and satellite imagery of planets. Complete the discussion by talking about the importance of military reconnaissance to national security.

### **EVALUATION:**

Students should be evaluated based on the:

- Completion of Launch Log 9.7
- Photo interpretations
- Aerial map
- Military reconnaissance interpretation and briefing

### **Notes**

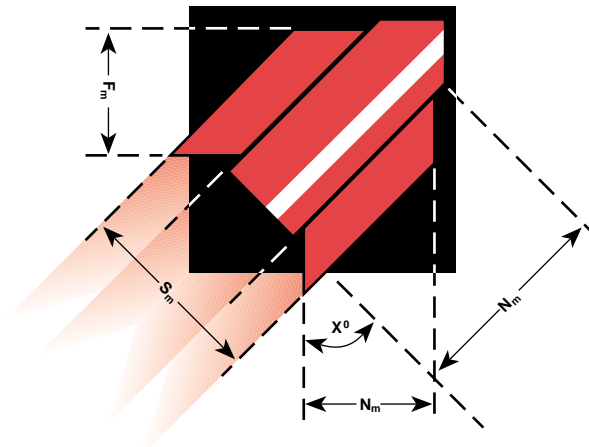

# ESTES EDUCATOR™

## LAUNCH LOGS



© 1995, 1999 Centuri Corporation.  
All rights reserved.

Name \_\_\_\_\_

## Laws of Motion

The moon is held in the orbit of the earth by what force?

What is the resistance that all objects moving through the air encounter?

What is the inertia possessed by non-moving objects called?

Mass times velocity equals \_\_\_\_\_.

If the same thrust is applied to a small mass as to a large mass, which mass will acceleration more?

In your own words, define each of Newton's three laws of motion.

Newton's First Law of Motion -

Newton's Second Law of Motion -

Newton's Third Law of Motion -



Name \_\_\_\_\_

## Design Considerations for Fins

Provide a thumbnail sketch of a rocket for each of the four common fin shapes. Identify the fin shape below each sketch.

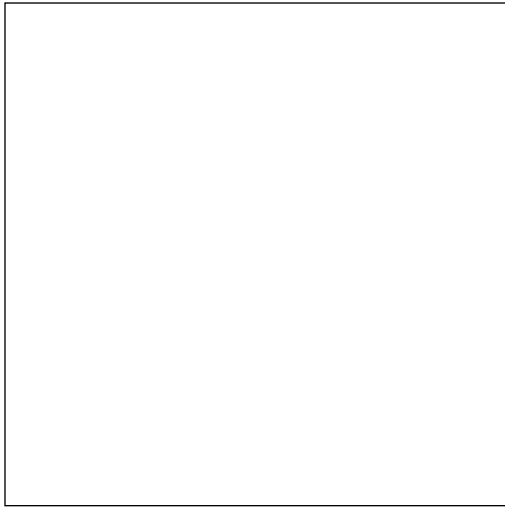

\_\_\_\_\_

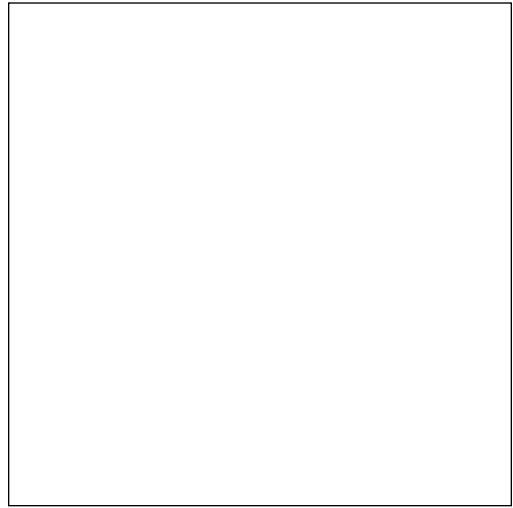

\_\_\_\_\_

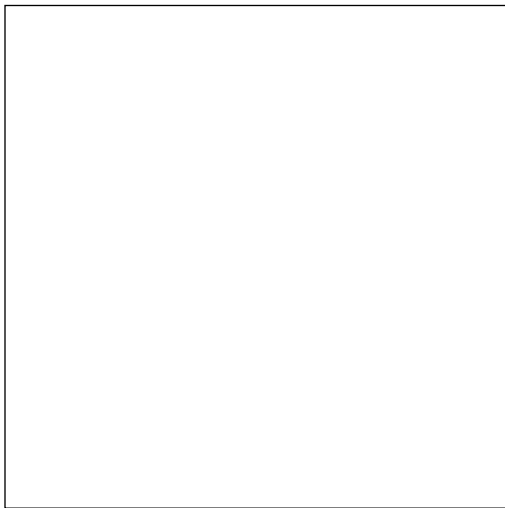

\_\_\_\_\_

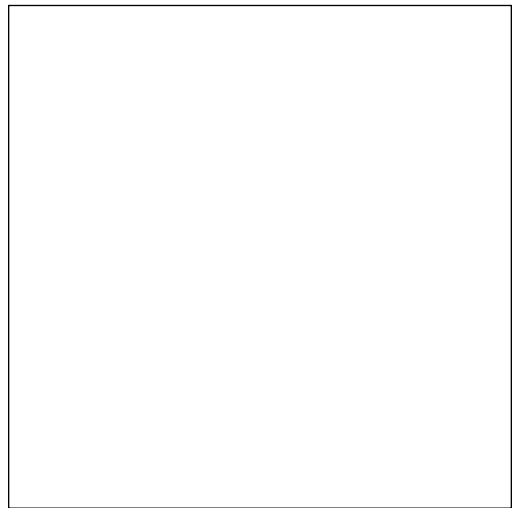

\_\_\_\_\_

Name \_\_\_\_\_

## Design Considerations for Nose Cones

Provide a thumbnail sketch of a nose cone for each of the rockets below.

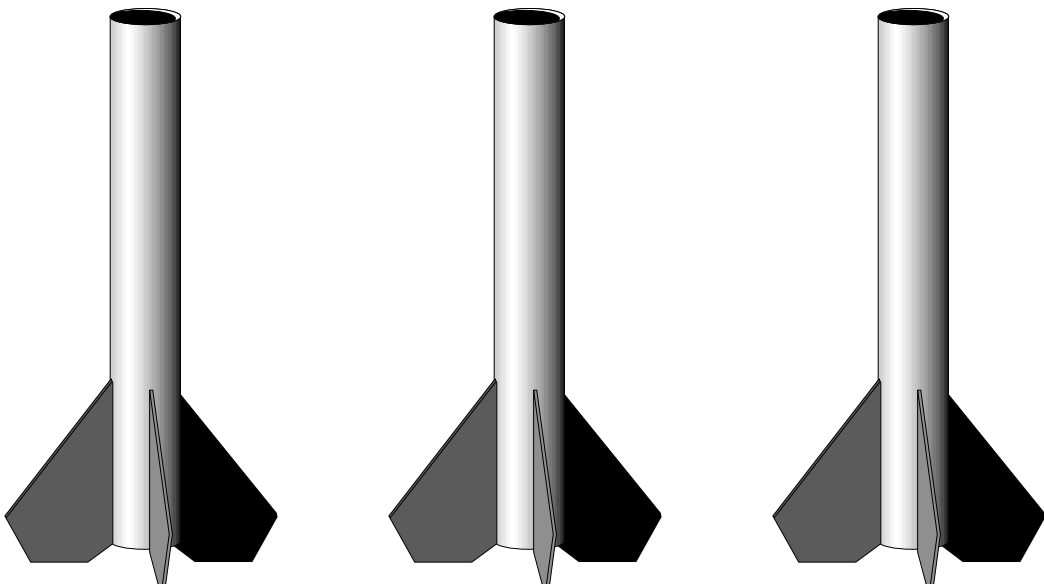

In your own words, define:

Drag -

Pressure Drag -

Friction Drag -





Name \_\_\_\_\_

# Rocket Payloads

Find examples of five different payloads that have been launched into space and provide the following information for each:

**Payload #1**

Type of Payload \_\_\_\_\_  
Date of Launch \_\_\_\_\_  
Approximate Size \_\_\_\_\_  
Weight \_\_\_\_\_  
Method of Launch \_\_\_\_\_

**Payload #2**

Type of Payload \_\_\_\_\_  
Date of Launch \_\_\_\_\_  
Approximate Size \_\_\_\_\_  
Weight \_\_\_\_\_  
Method of Launch \_\_\_\_\_

**Payload #3**

Type of Payload \_\_\_\_\_  
Date of Launch \_\_\_\_\_  
Approximate Size \_\_\_\_\_  
Weight \_\_\_\_\_  
Method of Launch \_\_\_\_\_

**Payload #4**

Type of Payload \_\_\_\_\_  
Date of Launch \_\_\_\_\_  
Approximate Size \_\_\_\_\_  
Weight \_\_\_\_\_  
Method of Launch \_\_\_\_\_

**Payload #5**

Type of Payload \_\_\_\_\_  
Date of Launch \_\_\_\_\_  
Approximate Size \_\_\_\_\_  
Weight \_\_\_\_\_  
Method of Launch \_\_\_\_\_

Draw thumbnail sketches for five different payload designs.

1	2	3	4	5
---	---	---	---	---

Name \_\_\_\_\_

## Payloads and Effects on Altitude

Name 4 examples of payloads mentioned in Technical Note TN-4 “The Fine Art of Payload Launching.”

1.

2.

3.

4.

What animals have a slim chance of surviving a launch and should not be considered a suitable payload?

Record the results of the six launches and graph the results.

Launch 1 (no payload) \_\_\_\_\_

Launch 2 (1oz. payload) \_\_\_\_\_

Launch 3 (2oz. payload) \_\_\_\_\_

Launch 4 (3oz. payload) \_\_\_\_\_

Launch 5 (4oz. payload) \_\_\_\_\_

Launch 6 (5oz. payload) \_\_\_\_\_

Name \_\_\_\_\_

## Recovery Systems

What is the primary purpose of a rocket recovery system?

Give the advantages and disadvantages for each of the recovery systems listed below.

### Featherweight Recovery:

Advantages

Disadvantages

### Tumble Recovery:

Advantages

Disadvantages

### Streamer Recovery:

Advantages

Disadvantages

### Parachute Recovery:

Advantages

Disadvantages

### Helicopter Recovery:

Advantages

Disadvantages

### Glider Recovery:

Advantages

Disadvantages

Name \_\_\_\_\_

## Testing Parachute Recovery Systems

Draw thumbnail sketches for five different parachute canopy designs.

1	2	3	4	5
---	---	---	---	---

Transfer each design to graph paper and calculate surface area of each design as demonstrated by teacher.

---

**Parachute Design #1**

Surface Area \_\_\_\_\_ sq. in.

Show work

---

**Parachute Design #2**

Surface Area \_\_\_\_\_ sq. in.

Show work

---

**Parachute Design #3**

Surface Area \_\_\_\_\_ sq. in.

Show work

---

**Parachute Design #4**

Surface Area \_\_\_\_\_ sq. in.

Show work

---

**Parachute Design #5**

Surface Area \_\_\_\_\_ sq. in.

Show work



## Constructing and Testing the Parachutes

- 1 Using the materials supplied by your teacher, your team should construct five different parachute recovery systems.
- 2 After constructing these recovery systems, your teams should take them to the designated parachute testing area.
- 3 Obtain a stop watch from your teacher.
- 4 Clip one of your team’s parachutes in the clothes pin as shown in the illustration.
- 5 Pull the string until the clothes pin comes in contact with the screw eye mounted to the ceiling.
- 6 On the count of three, tug on the string to release the parachute and start the stop watch.
- 7 As soon as the weight on the parachute comes in contact with the floor, stop the stop watch and record the time in the chart below.
- 8 Time and record the elapsed descent time five times for each parachute.
- 9 Finally, calculate and record the average time for each parachute design.

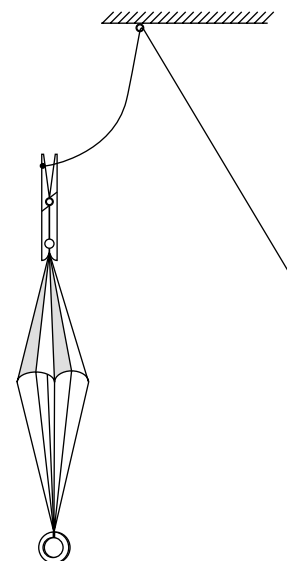

	Time of Descent Trial #1	Time of Descent Trial #2	Time of Descent Trial #3	Time of Descent Trial #4	Time of Descent Trial #5	Average Time of Descent
Design #1						
Design #2						
Design #3						
Design #4						
Design #5						

Which design had the longest average time of descent? Why?

Which design had the shortest average time of descent? Why?

## Calculating Descent Time to Surface Area Ratios

In order to determine your team's most efficient parachute design, you will need to calculate the descent time to surface area ratio of each parachute. After obtaining the surface areas from page 1 and descent times from page 2, use the following formula to calculate the descent time to surface area ratio:

$$\text{Descent time to surface area ratio} = \frac{\text{Average descent time of sample (sec.)}}{\text{Surface area of same sample (sq. in.)}}$$

### Example:

A particular design has a surface area of 164.88 square inches and an average descent time of 2.77 seconds.

$$\text{Descent time to surface area ratio} = \frac{2.77 \text{ sec.}}{164.88 \text{ sq. in.}}$$

$$\text{Descent time to surface area ratio} = .0168 \text{ sec./sq. in.}$$

### Parachute Design #1

Surface Area \_\_\_\_\_ sq. in.

Descent Time \_\_\_\_\_ sec.

Descent Time to Surface Area Ratio \_\_\_\_\_ sec./sq. in.

### Parachute Design #2

Surface Area \_\_\_\_\_ sq. in.

Descent Time \_\_\_\_\_ sec.

Descent Time to Surface Area Ratio \_\_\_\_\_ sec./sq. in.

### Parachute Design #3

Surface Area \_\_\_\_\_ sq. in.

Descent Time \_\_\_\_\_ sec.

Descent Time to Surface Area Ratio \_\_\_\_\_ sec./sq. in.

---

**Parachute Design #4**

Surface Area \_\_\_\_\_ sq. in.

Descent Time \_\_\_\_\_ sec.

Descent Time to Surface Area Ratio \_\_\_\_\_ sec./sq. in.

---

**Parachute Design #5**

Surface Area \_\_\_\_\_ sq. in.

Descent Time \_\_\_\_\_ sec.

Descent Time to Surface Area Ratio \_\_\_\_\_ sec./sq. in.

---

Which parachute has the best descent time to surface area ratio?

Is this the same parachute with the best average descent time? Why?

How could this design be improved?

Name \_\_\_\_\_

## Parts of a Model Rocket

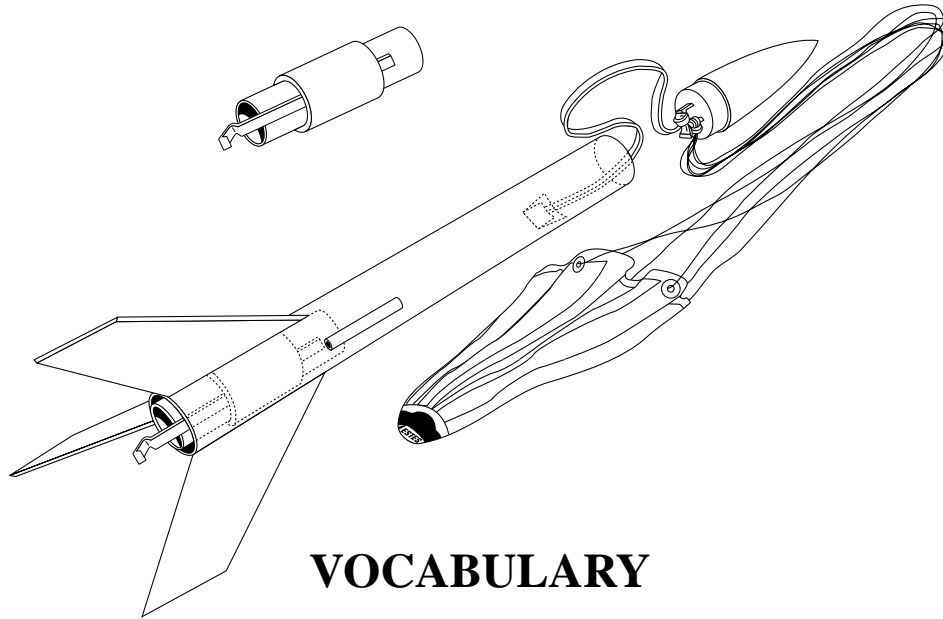

## VOCABULARY

**Nose Cone** - The foremost surface of a model rocket that is shaped to reduce drag. Usually made of balsa or plastic.

**Body Tube** - A specially wound and treated cardboard or plastic cylinder used to make the fuselage or airframe of a model rocket.

**Launch Lug** - Round, hollow tube which slips over the launch rod to guide the model during the first few feet of flight until sufficient airspeed is reached allowing the fins to operate.

**Fins** - The stabilizing and guiding unit of a model rocket; an aerodynamic surface projecting from the rocket body for the purpose of giving the rocket directional stability.

**Recovery System** - A device incorporated into a model rocket for the purpose of returning it to the ground in a safe manner. Usually achieved by creating drag or lift to oppose the acceleration of gravity. All models must employ a recovery system, such as a parachute.

**Balsa Wood** - A very light, strong wood grown in Ecuador and used in the structure of model airplanes and model rockets.

**Parachute** - A drag producing device, generally hemispherical (half-sphere) in shape. Parachutes used in model rockets are generally made from light plastic and are used to gently recover the payload package, rocket body, etc.

**Shroud Line** - The cord or string used to attach the parachute to the nose cone.

**Shock Cord** - The elastic cord used to attach the recovery system to the body of the rocket. Its elasticity absorbs shock when the recovery system deploys.

**Shock Cord Mount** - Used to attach the shock cord to the interior of the body tube.

**Engine Mount Assembly** - Safely secures the engine in a model rocket.

Name \_\_\_\_\_

## Parts of a Model Rocket

**Directions:** Give the names for each of the parts of the model rocket shown below.

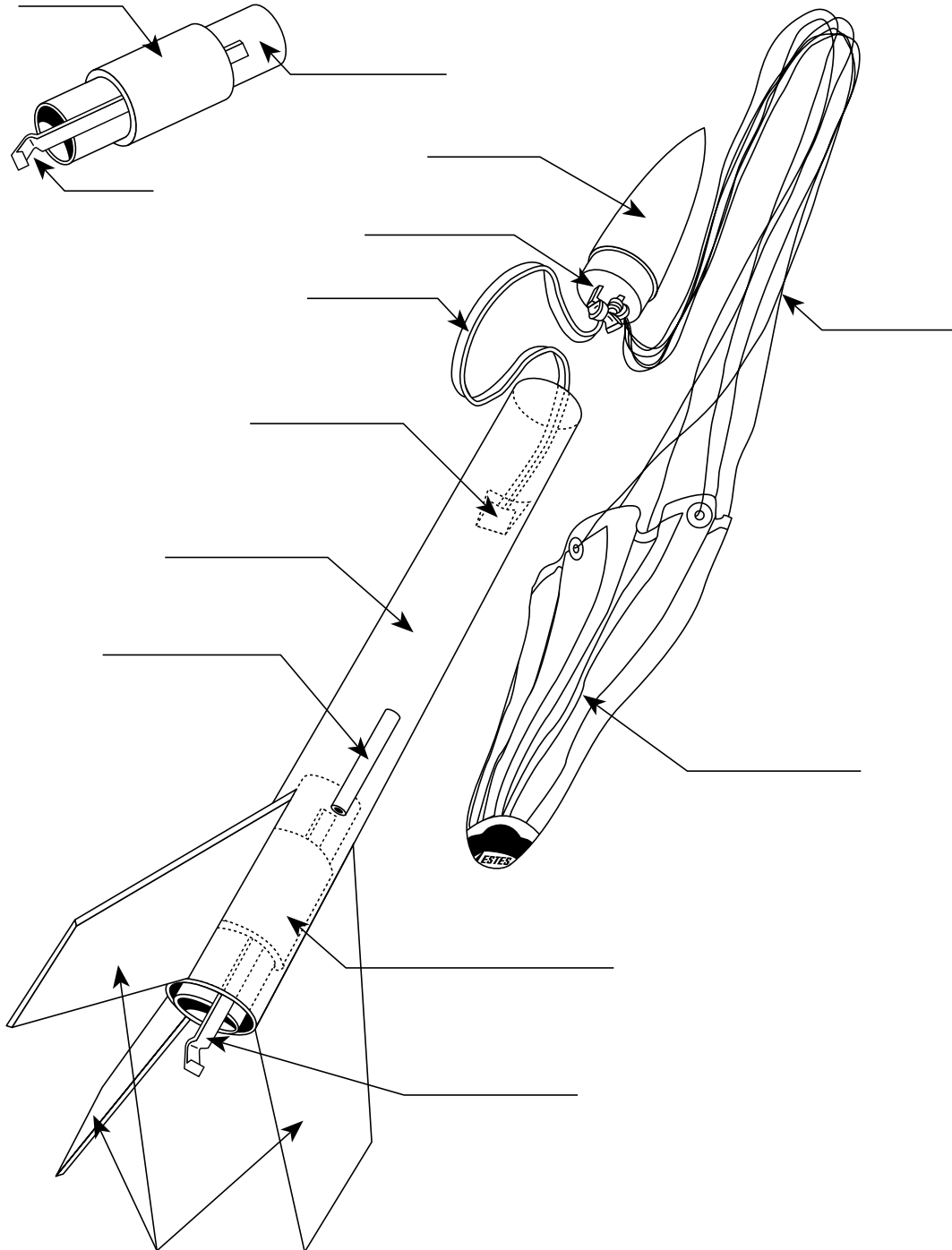

Name \_\_\_\_\_

## Parts of a Model Rocket

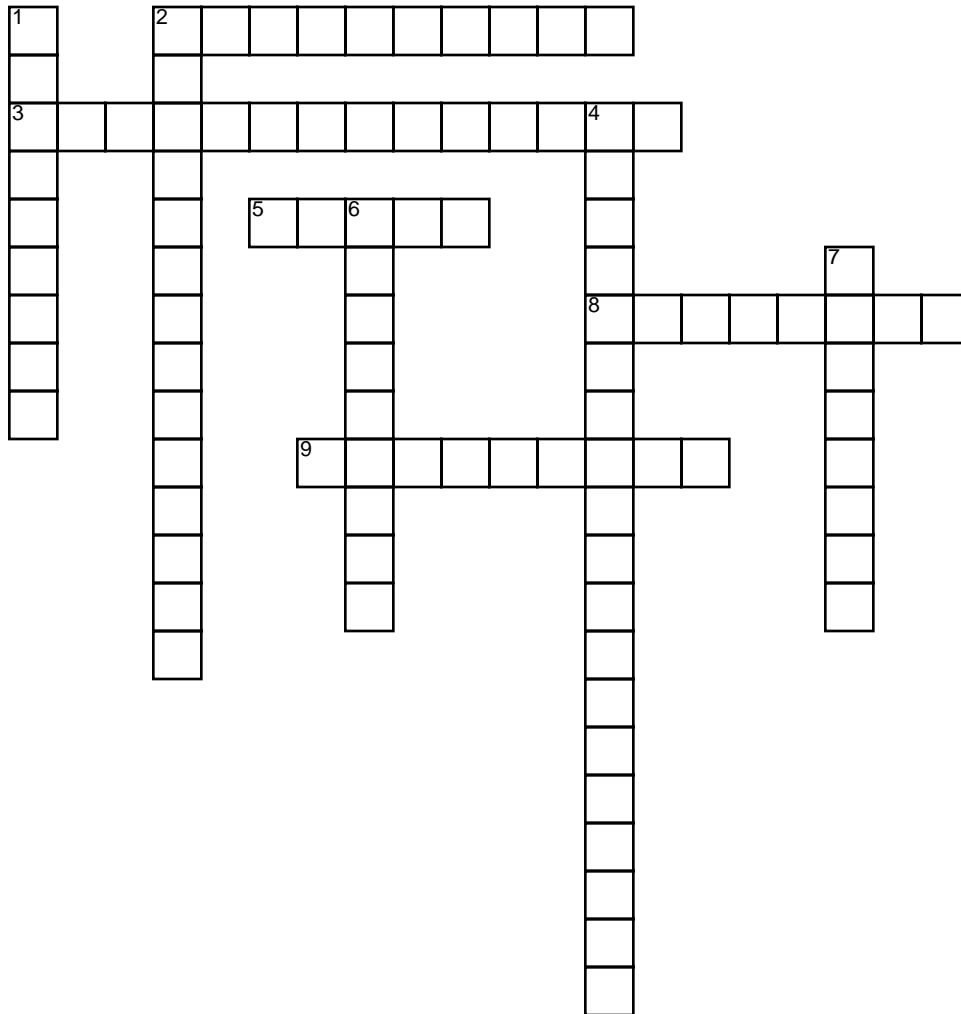

### ACROSS

- Used to attach the parachute to the nose cone (2 words)
- Device which returns rocket to the ground in a safe manner (2 words)
- A very strong, light wood
- Foremost surface of a rocket (2 words)
- Absorbs the shock when the recovery system deploys (2 words)

### DOWN

- Used to gently recover the payload, rocket body, etc.
- Used to attach shock cord to the interior of the body tube (3 words)
- Safely secures engine (3 words)
- Guides the rocket during the first few feet of flight (2 words)
- The fuselage or airframe of a model rocket (2 words)

Name \_\_\_\_\_

## Evaluation Criteria

List the team's proposed criteria below. Each item should be rated 1-3, with 1 being the least important and 3 being the most important. This will allow the most important criteria to carry the most weight in the overall evaluation.

Proposed Criteria	Weight 1-3

Make three thumbnail sketches for the team's prototype.

1

2

3

Name \_\_\_\_\_

## Evaluation Criteria

List the criteria established by the class below. Each item should be rated 1-3, with 1 being the least important and 3 being the most important. This will allow the most important criteria to carry the most weight in the overall evaluation. Prototypes should be evaluated for each item with a rating of 1-5 using the following scale:

- 1 - Fails
- 2 - Poor
- 3 - Average
- 4 - Good
- 5 - Excellent

The score is calculated by multiplying the weight for the item by the prototypes rating. The total of the individual item's scores will given the prototype its overall score.

Established Criteria	Weight 1-3	Rating 1-5	Score W X R
		Total	







Name \_\_\_\_\_

# Storyboard

Video: _____	Instructions: _____
Sequence #: _____	

Video: _____	Instructions: _____
Sequence #: _____	

Name \_\_\_\_\_

# Storyboard

Video: _____	Instructions: _____
Sequence #: _____	

Video: _____	Instructions: _____
Sequence #: _____	

Name \_\_\_\_\_

Video: _____ Sequence #: _____	Instructions: _____

Video: _____ Sequence #: _____	Instructions: _____

Name \_\_\_\_\_

# NAR Model Rocketry Safety Code

The safety code was formulated by experienced rocketeers and has evolved with model rocketry. It should be followed in every model rocketry activity.

**1. Materials** - My model rocket will be made of lightweight materials such as paper, wood, rubber, and plastic suitable for the power used and the performance of my model rocket. I will not use any metal for the nose cone, body, or fins of my model rocket.

**2. Engines/Motors** - I will use only commercially-made NAR certified model rocket engines in the manner recommended by the manufacturer. I will not alter the model rocket engine, its parts, or its ingredients in any way.

**3. Recovery** - I will always use a recovery system in my model rocket that will return it safely to the ground so that it may be flown again. I will use only flame resistance recovery wadding if required.

**4. Weight and Power Limits** - My model rocket will weight no more that 1,500 grams (53 ounces) at liftoff, and its rocket engines will produce no more than 320 newton-seconds (4.45 newtons equal 1.0 pound) of total impulse. My model rocket will weigh no more than the engine manufacturer’s recommended maximum liftoff weight for the engines used, or I will use engines recommended by the manufacturer for my model rocket.

**5. Stability** - I will check the stability of my model rocket before its first flight, except when launching a model rocket of already proven stability.

**6. Payloads** - Except for insects, my model rocket will never carry live animals or a payload that is intended to be flammable, explosive, or harmful.

**7. Launch Site** - I will launch my model rocket outdoors in a cleared area, free of tall trees, power lines, buildings, and dry brush and grass. My launch site will be at least as large as that recommended in the following table:

### LAUNCH SITE DIMENSIONS

Engines	Site Diameter		Estes Recommended Maximum Altitude	
	Feet	Meters	Feet	Meters
1/2 A	50	15	200	61
A	100	30	400	122
B	200	60	800	244
C	400	120	1600	488
D	500	150	1800	549

Minimum launch site in dimension for a circular area is diameter in feet/meters and for rectangular area is shortest side in feet/meters.

**8. Launcher** - I will launch my model rocket from a stable launching device that provides rigid guidance until the model rocket has reached a speed adequate to ensure a safe flight path. To prevent accidental eye injury, I will always place the launcher so that the end of the rod is above eye level or I will cap the end of the rod when approaching it. I will cap or disassemble my launch rod when not in use, and I will never store it in an upright position. My launcher will have a jet deflector device to prevent the engine exhaust from hitting the ground directly. I will always clear the area around my launch device of brown grass, dry weeds, or other easy-to-burn materials.

**9. Ignition System** - The system I will use to launch my model rocket will be remotely controlled and electrically operated. It will contain a launching switch that will return to “off” when released. The system will contain a removable safety interlock in series with the launch switch. All persons will remain at least 15 feet (5 meters) from the model rocket when I am igniting model rocket engines totaling 30 newton-seconds or less of total impulse and at least 30 feet (9 meters) from the model rocket when I am igniting model rocket engines totaling more than 30 newton-seconds of total impulse. I will use only electrical igniters recommended by the engine manufacturer that will ignite model rocket engine(s) within one second of actuation of the launching switch.

**10. Launch Safety** - I will ensure that people in the launch area are aware of the pending model rocket launch and can see the model rocket’s liftoff before I begin my audible five-second countdown. I will not launch a model rocket using it as a weapon. If my model rocket suffers a misfire, I will not allow anyone to approach it or the launcher until I have made certain that the safety interlock has been removed or that the battery has been disconnected from the ignition system. I will wait one minute after a misfire before allowing anyone to approach the launcher.

**11. Flying Conditions** - I will launch my model rocket only when the wind is less than 20 miles (30 kilometers) an hour. I will not launch my model rocket so it flies into clouds, near aircraft in flight, or in a manner that is hazardous to people or property.

**12. Pre-Launch Test** - When conducting research activities with unproven model rocket designs or methods I will, when possible, determine the reliability of my model rocket by pre-launch tests. I will conduct the launching of an unproven design in complete isolation from persons not participating in the actual launching.

**13. Launch Angle** - My launch device will be pointed within 30 degrees of vertical. I will never use model rocket engines to propel any device horizontally.

**14. Recovery Hazards** - If a model rocket becomes entangled in a power line or other dangerous place, I will not attempt to retrieve it.

This is the official Model Rocketry Safety Code of the National Association of Rocketry and Model Rocket Manufacturers Association.

The largest legal “model” rocket engine, as defined by CPSC, is an “F” (80NS) engine. To launch rockets weighing over one pound including propellant or rockets containing more than 4.4 ounces (net weight) of propellant, you need to obtain a waiver from the FAA. Check your telephone directory for the FAA office nearest you.

Name \_\_\_\_\_

**Directions:** Complete the following checkup of your knowledge of the NAR Model Rocketry Safety Code.

1. The nose cone, body, or fins of my model rocket will be made of what types of material?
2. Use only \_\_\_\_\_ operated ignition systems to launch model rockets.
3. My model rocket can carry only what type of live animals as a payload?
4. What is the maximum weight in grams of my model rocket (including engine) at liftoff?
5. The only acceptable type of wadding is \_\_\_\_\_ wadding.
6. Can you safely launch a model rocket with a "C" engine at a launch that is 300 feet in diameter?
7. What is the largest engine I can use to launch my model rocket if my launch site is a rectangular area that is 300 feet by 425 feet?
8. What is the maximum total impulse in newton-seconds that my rocket engine may produce?
9. Launch area should be free of debris, especially \_\_\_\_\_.



Name \_\_\_\_\_

10. One pound equals how many newtons?
  
11. You should \_\_\_\_\_ attempt to recover a model rocket from power lines or other dangerous places.
  
12. If a rocket engine produces 89 newton-seconds of total impulse, that is the same as saying it produces how many pound-seconds of total impulse?
  
13. If model rocket uses an engine that produces 37.5 newton-seconds of total impulse, all persons must be how many feet away from the model rocket at the time of launch?
  
14. You can safely launch a model rocket when the wind is less than \_\_\_\_\_ miles an hour.
  
15. Can you safely launch a model rocket 25 degrees from vertical? What is the maximum degrees from vertical you can safely launch a model rocket?
  
16. What is the largest “model” rocket engine, as defined by CPSC?
  
17. How long must you wait before approaching a rocket which has misfired?
  
18. What 2 conditions may require a waiver from the FAA prior to the launch of a model rocket?





Name \_\_\_\_\_

## Determining Height & Altitude

Directions: Use graph paper and a protractor to find the height or altitude of the following examples. Refer to Technical Report TR-3 "Altitude Tracking" as needed.

**Example #1:**

Microwave tower

Angular distance =  $74^\circ$ 

Baseline = 100 feet

Height = \_\_\_\_\_

**Example #2:**

Utility pole

Angular distance =  $52^\circ$ 

Baseline = 50 feet

Height = \_\_\_\_\_

**Example #3:**

Tall tree

Angular distance =  $81^\circ$ 

Baseline = 120 feet

Height = \_\_\_\_\_

**Example #4:**

Model rocket

Angular distance =  $57^\circ$ 

Baseline = 500 feet

Height = \_\_\_\_\_

Name \_\_\_\_\_

## Calculating Altitude

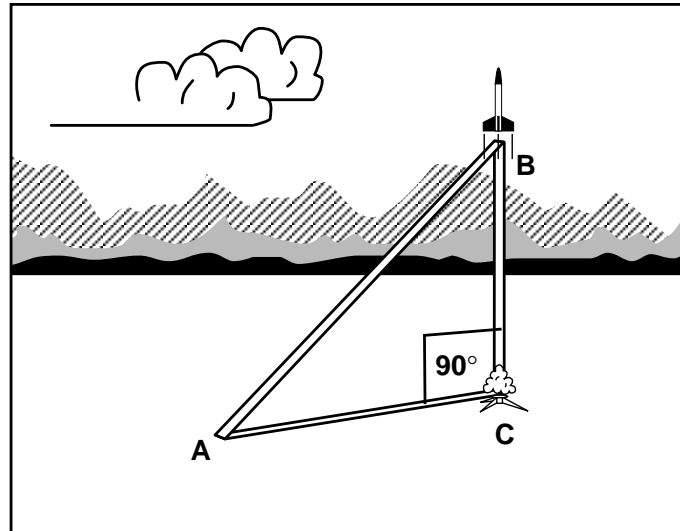

**Baseline** - The distance from point A (tracking station) to point C (launch pad).

**Angular Distance** - Determined by measuring the angle between the rocket's position on the launch pad and the highest point reached by the rocket (point B) as seen by the tracking station or observer (point A).

**Height** - Distance from point C to point B.

$$\text{Height} = \text{Tangent of angular distance} \times \text{baseline}$$

**Note:** To minimize error due to wind effects, the baseline (AC) should be perpendicular to the wind direction when using single station tracking.

**Directions:** Use the formula above to find the height or altitude of the following examples. Refer to Technical Report TR-3 "Altitude Tracking" as needed.

### Example #1

Baseline = 320 feet

Angular distance =  $76^\circ$

Tangent of angular distance = \_\_\_\_\_

Height or altitude = \_\_\_\_\_

### Example #2

Baseline = 120 meters

Angular distance =  $49^\circ$

Tangent of angular distance = \_\_\_\_\_

Height or altitude = \_\_\_\_\_

Name \_\_\_\_\_

## Calculating Altitude

**Example #3**

Baseline = 200 feet

Angular distance =  $65^\circ$ 

Tangent of angular distance = \_\_\_\_\_

Height or altitude = \_\_\_\_\_

**Example #4**

Baseline = 325 feet

Angular distance =  $87^\circ$ 

Tangent of angular distance = \_\_\_\_\_

Height or altitude = \_\_\_\_\_

**Example #5**

Baseline = 200 meters

Angular distance =  $56^\circ$ 

Tangent of angular distance = \_\_\_\_\_

Height or altitude = \_\_\_\_\_

**Example #6**

Baseline = 175 meters

Angular distance =  $45^\circ$ 

Tangent of angular distance = \_\_\_\_\_

Height or altitude = \_\_\_\_\_

Name \_\_\_\_\_

## Parts of a Model Rocket Engine

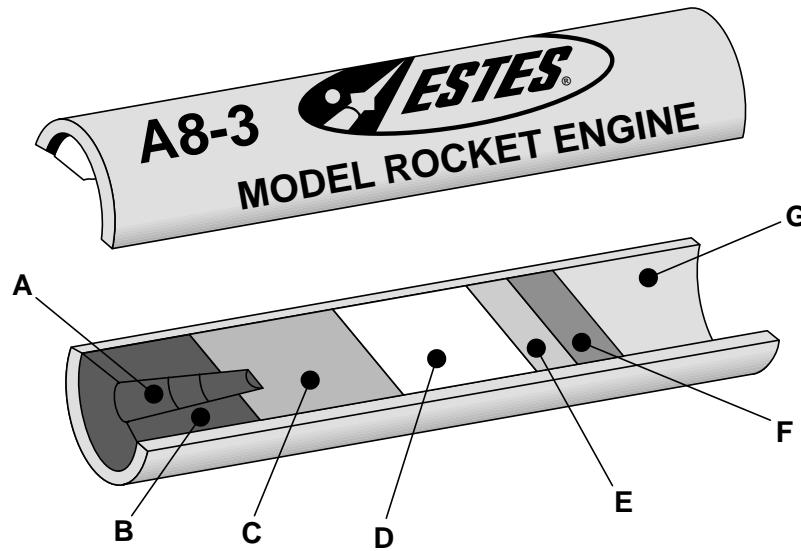

1. Give the names for each of the parts of the model rocket engine shown below then complete the questions that follow.

- |    |       |    |       |
|----|-------|----|-------|
| A. | _____ | B. | _____ |
| C. | _____ | D. | _____ |
| E. | _____ | F. | _____ |
| G. | _____ |    |       |

2. What is ignition?

3. What happens at burnout?

4. What is the purpose of the delay and tracking charge?

5. What happens at the ejection charge?

6. What is the purpose of the center bore?

Name \_\_\_\_\_

## Rocket Engine Characteristics

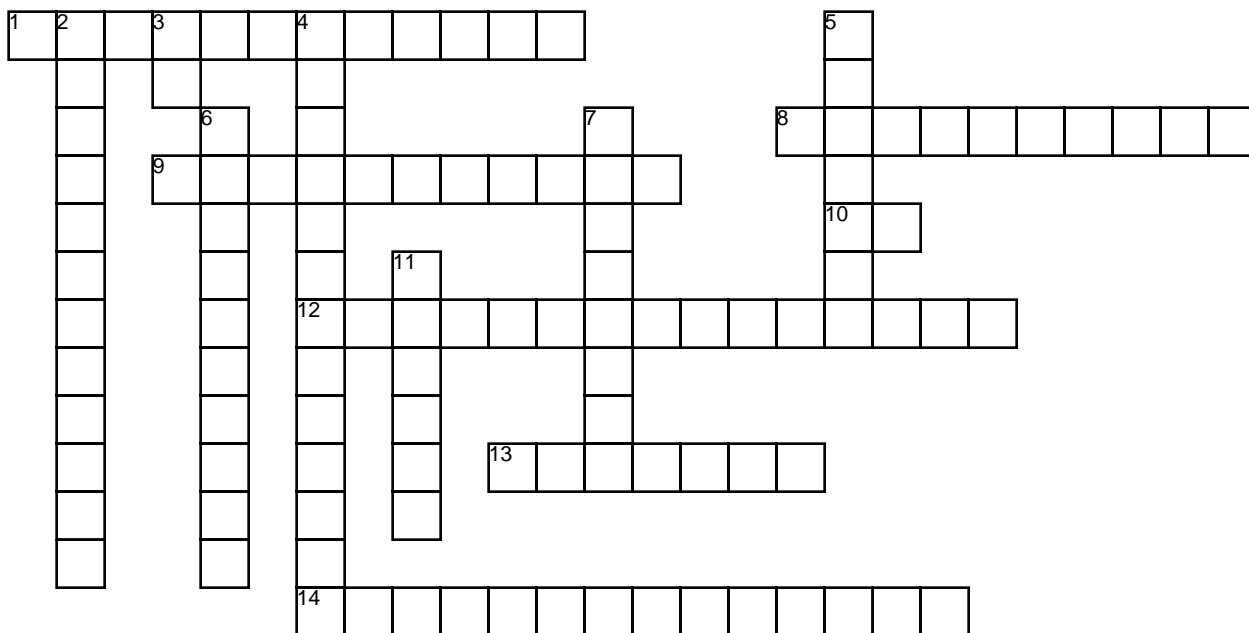

### ACROSS

- A series of numbers and letters that serve to identify the engine's performance capabilities.
- A chemical paste of a combustible nature that has been commercially developed and loaded in the casing of a model rocket engine that when ignited will provide the thrust necessary to launch a model rocket.
- A no thrust slow burning charge that permits the rocket to reach a maximum altitude by providing a time delay for the ejection of the recovery system. (2 Words)
- Outside diameter.
- The attributes of one model rocket engine that makes it distinct from another.
- An electrical device which initiates the combustion process in a rocket engine.
- The charge contained in single and upper stage engines which deploys the recovery system. (2 Words)

### DOWN

- That portion of the ceramic nozzle that allows the exhaust to exit the engine. It is also where the igniter is placed. (2 Words)
- Inside diameter
- Directs the exhaust gas through the throat, greatly increasing the exhaust gas velocity. (2 Words)
- The point at which a rocket engine ceases to produce thrust. Generally, the point at which all propellant has been burned.
- The end of the propellant charge that provides for easier ignition and is designed to provide a high initial thrust which accelerates the rocket to a suitable flying speed quickly. (2 Words)
- The instant at which a model rocket engine's propellant begins to burn.
- A paper cover that protects the charges of a rocket engine and contains the internal pressure during combustion.





Name \_\_\_\_\_

## Engine Selection

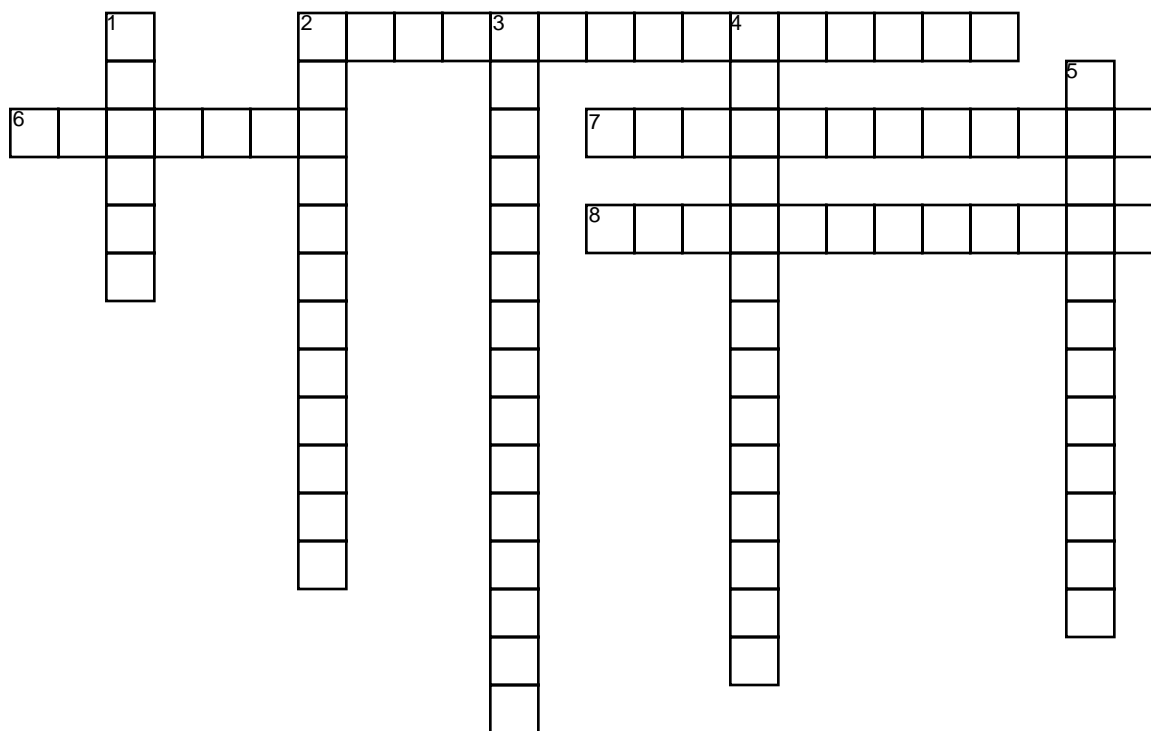

### ACROSS

2. A graphic expression of the relationship between thrust produced by a rocket engine and time. (3 words)
6. The point at which a rocket engine ceases to produce thrust. Generally the point at which all propellant has been burned.
7. The rapid movement of a model rocket during the first seconds of a launch.
8. The metric measurement of a model rocket engine's total impulse. (2 Words)

### DOWN

1. The propulsive force developed by an operating rocket engine caused by the rearward ejection of gasses.
2. The amount of thrust acting over a period of time, developed by a rocket engine; determined by measuring the area under the engine's thrust-time curve. (2 Words)
3. A measurement for determining the relative performance of a rocket propellant. (2 Words)
4. The charge contained in single and upper stage engines which deploys the recovery system. (2 Words)
5. The English measurement of a model rocket engine's total impulse. (2 Words)



Name \_\_\_\_\_

## Model Rocket Engine Experimentation

In the grid space below, create a bar graph that explains the results of your data collection. Your graph should compare the maximum altitude at apogee of the various model rocket engine types used. If available, use colored marks to identify the different model rocket engines used.

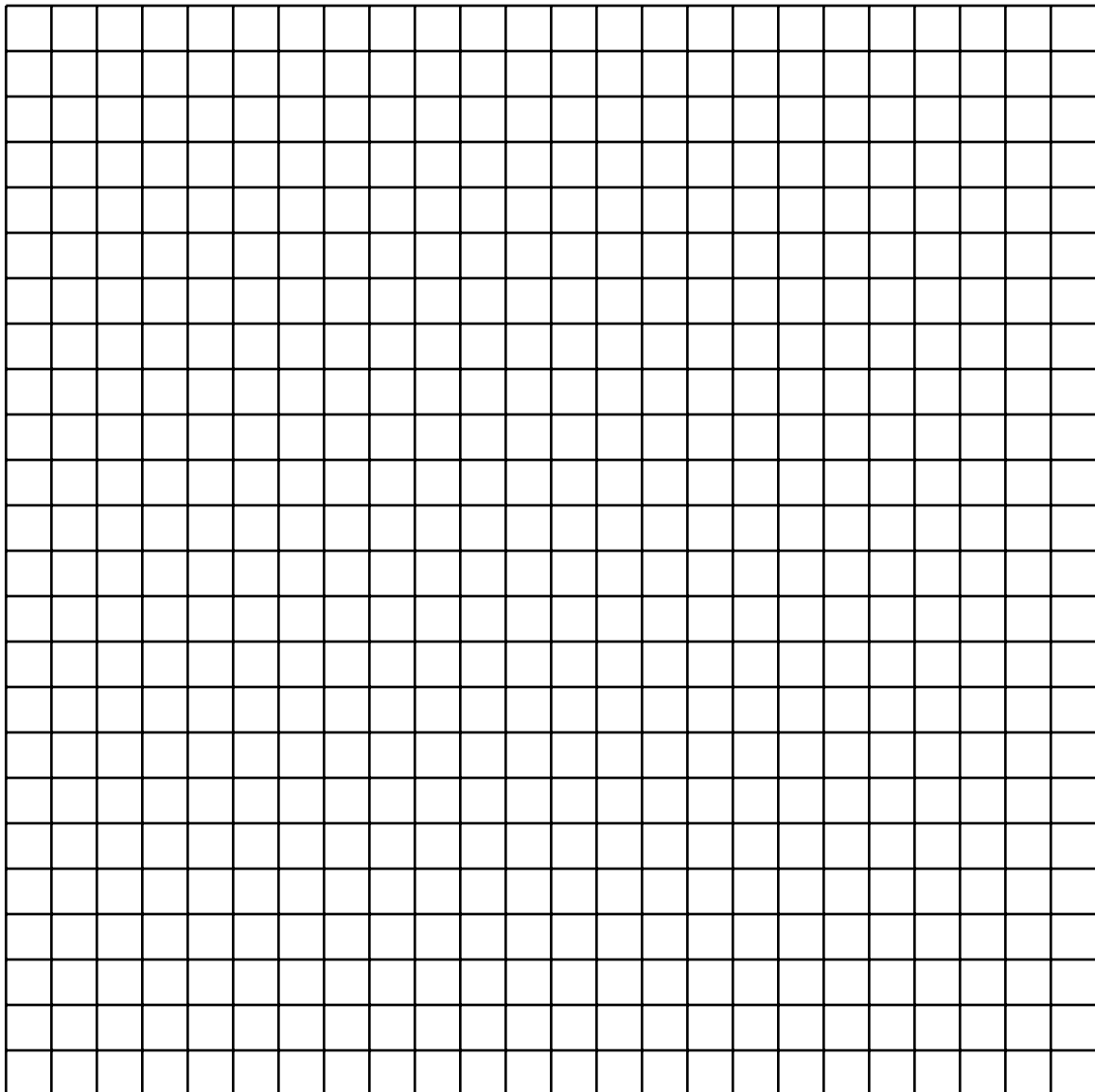

Name \_\_\_\_\_

## Model Rocket Launcher Circuits

In the space provided below, draw a pictorial sketch of a rocket launcher system.

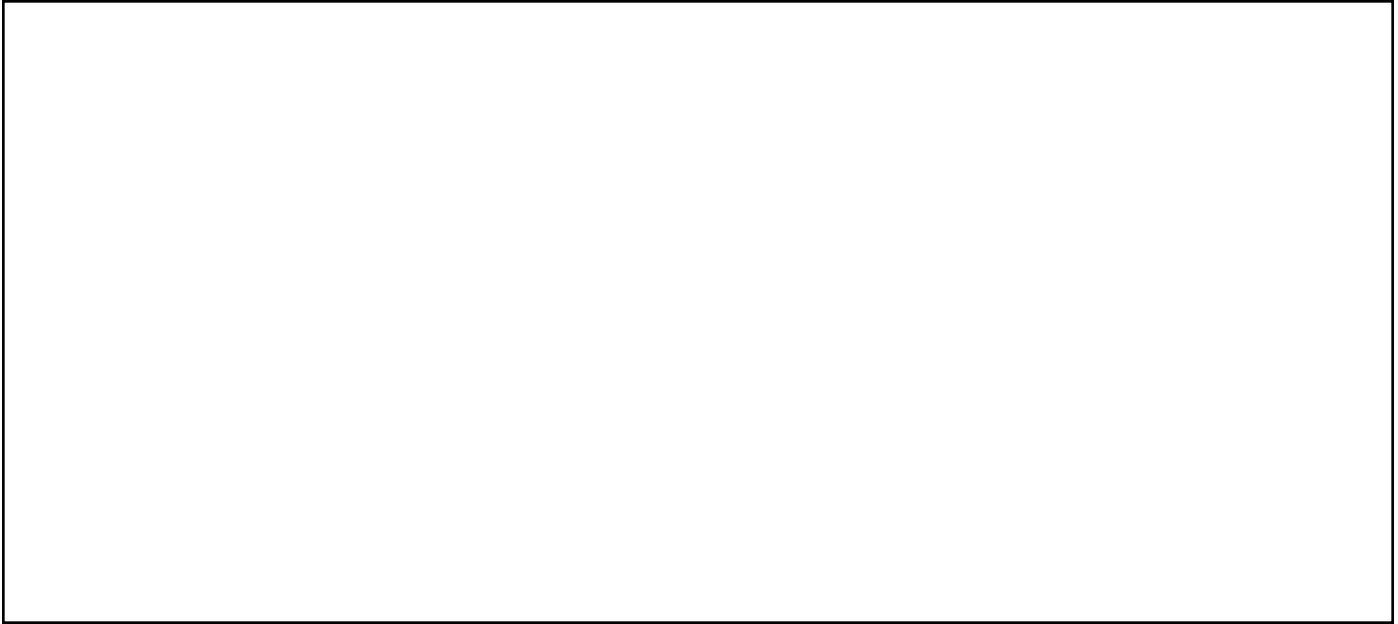

In the space provided below, draw a schematic of a model rocket launcher system.



Name \_\_\_\_\_

## Launch Equipment Circuitry

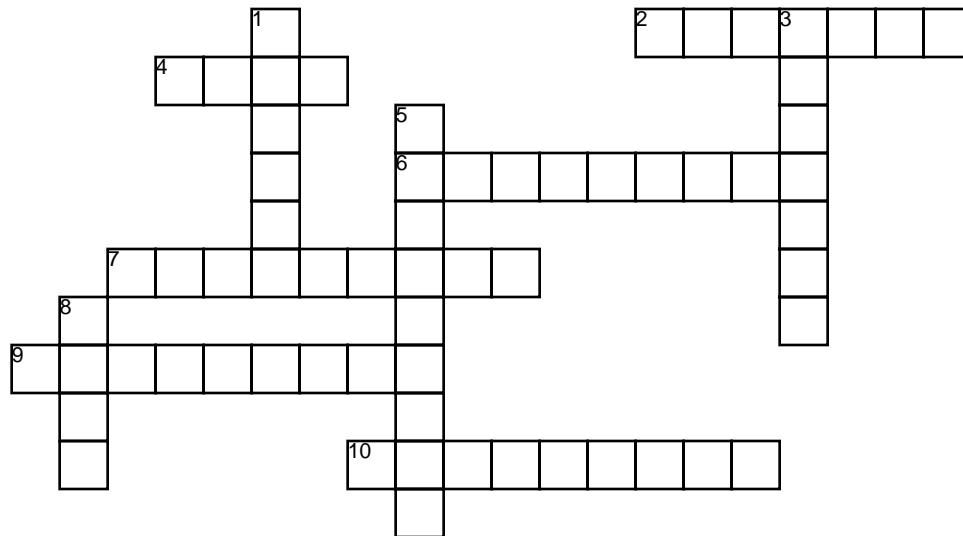

### ACROSS

2. The complete path of an electric current including the source of electricity.
4. Unit of electrical measurement measuring resistance.
6. A material that resists the flow of electrons.
7. A drawing of an electronic circuit that shows the circuit and the components.
9. A material that allows for the flow of electrons.
10. A special key used to activate a launch system. (2 Words)

### DOWN

1. The unit used in measuring the strength of an electrical current.
3. The movement of electricity or rate of electrical flow; measured in amperes.
5. A three dimensional drawing that shows the size shape and type of object.
8. The unit of electromotive force.

Name \_\_\_\_\_

## Multiple Rocket Launcher Circuits

In the space provided below, draw an electrical schematic of a multiple rocket launcher system.

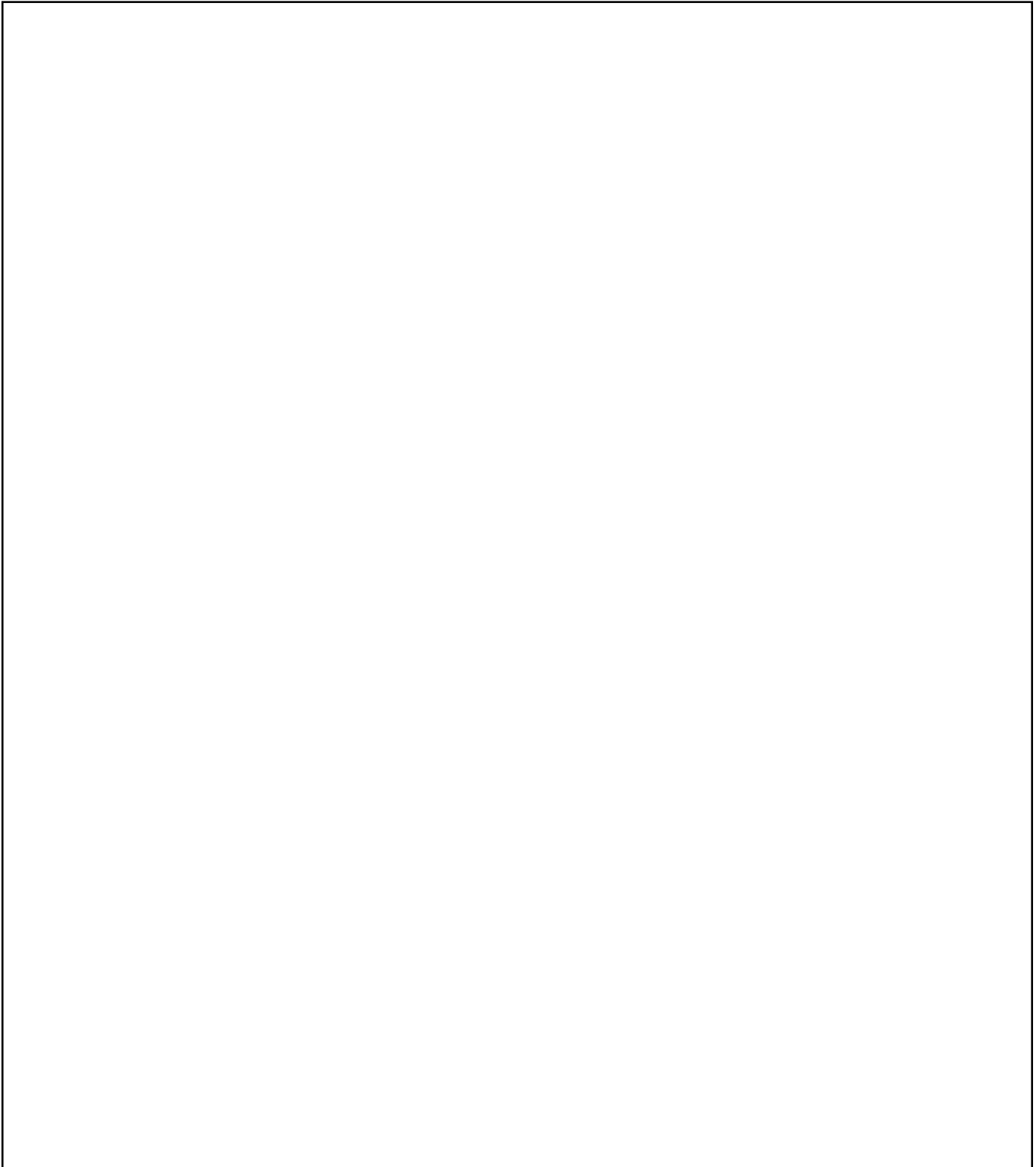
A large, empty rectangular box with a thin black border, intended for the student to draw an electrical schematic of a multiple rocket launcher system.







Name \_\_\_\_\_

## Mission Logo

**Directions:** All missions for NASA have a mission patch. This mission patch is basically a graphics logo. This logo will generally depict some important aspect of the mission and be used as a way of identifying the mission and making it unique. In the space provided below, draw several thumbnail sketches of your ideas for your mission logo.

1	2	3	4	5
---	---	---	---	---

Samples of Space Shuttle Mission Patches  
Courtesy of NASA



Name \_\_\_\_\_

## Mission Logo

**Directions:** In the space provided below, draw several rough sketches of your ideas for your mission logo. A rough sketch is a freehand drawing that outlines the basic idea of how something to be printed is to be setup. Create your own from scratch.

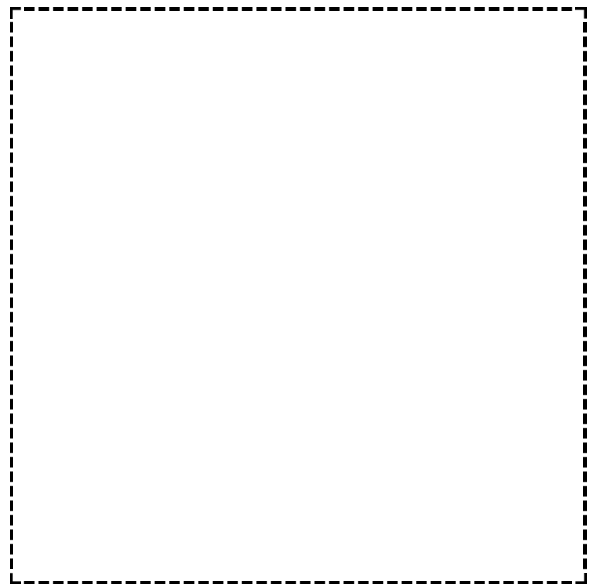
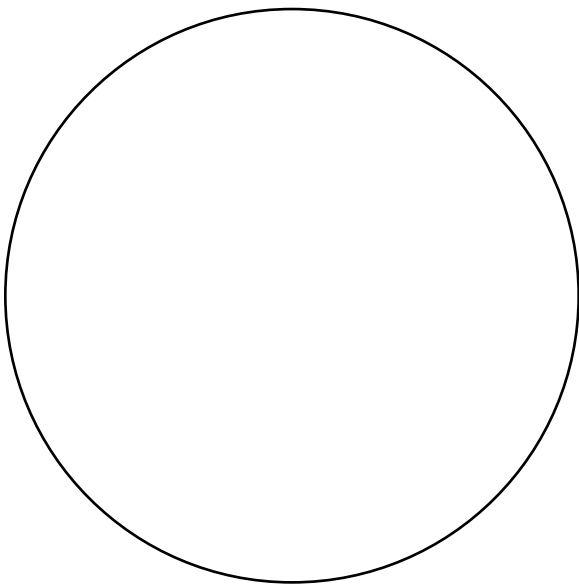
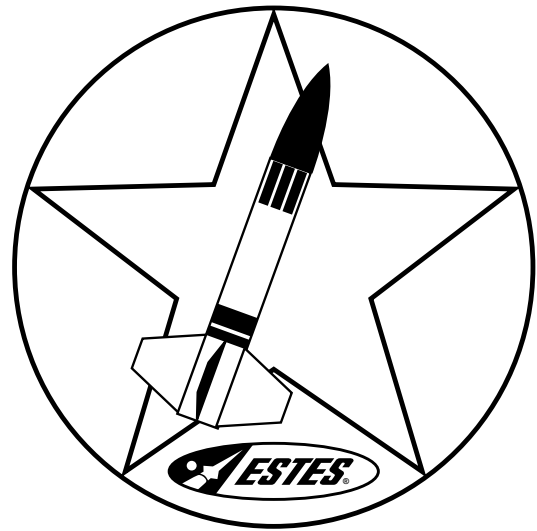
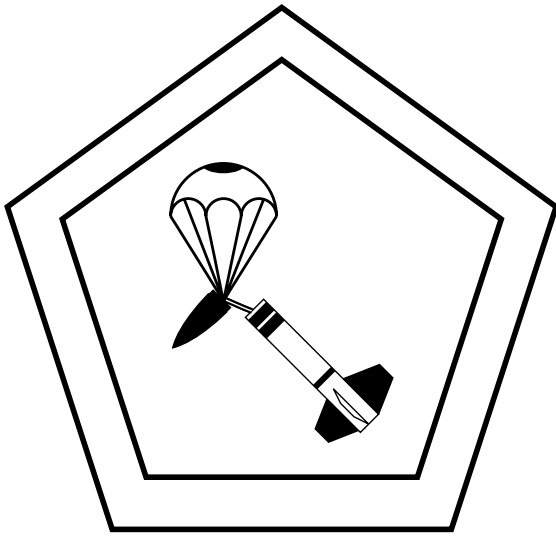

Create your own from scratch

Name \_\_\_\_\_

## Mission Logo



Courtesy of NASA

**Directions:** In the space provided below, develop a final layout of your best logo idea.

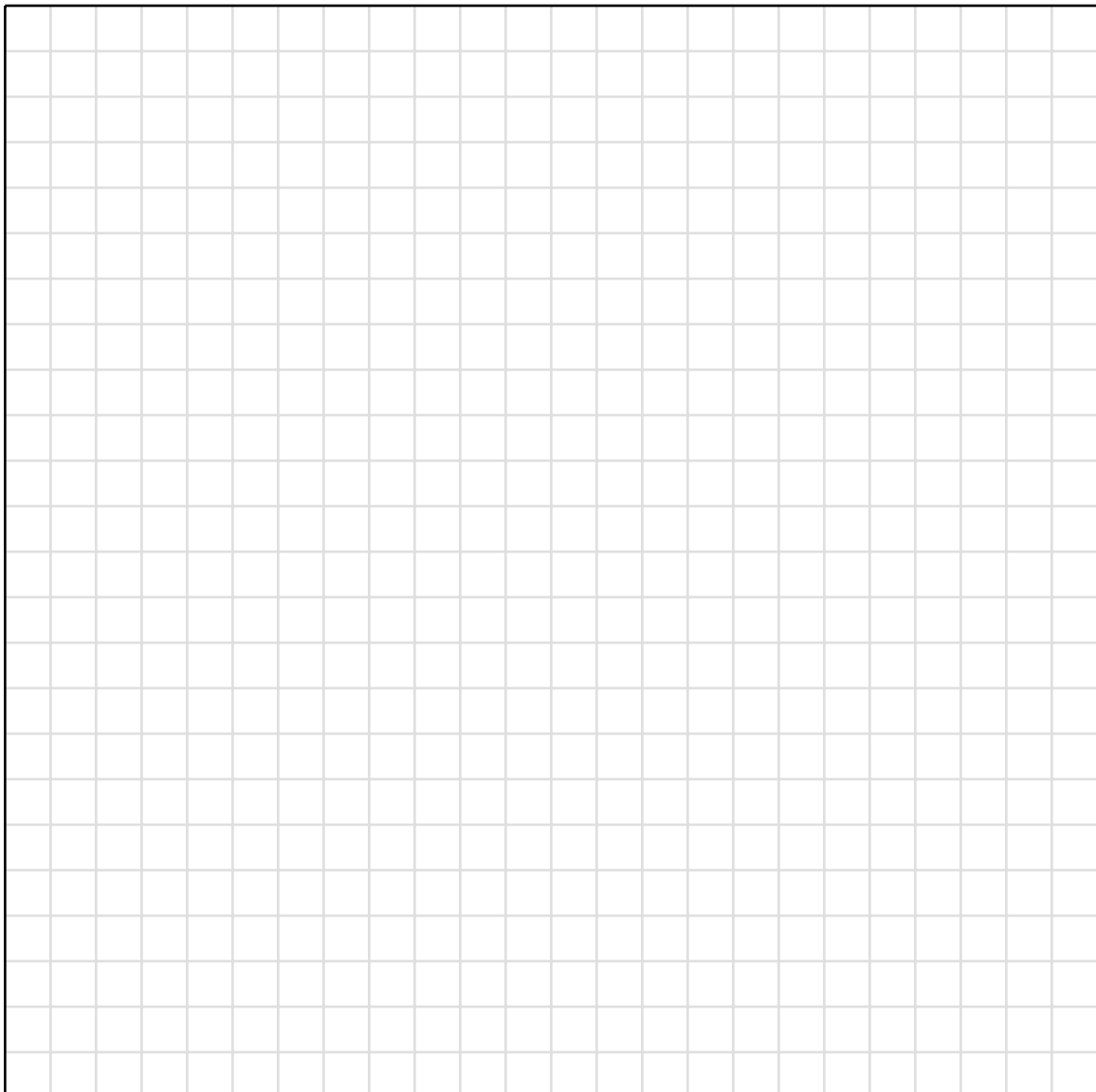

Name \_\_\_\_\_

## Spacelink

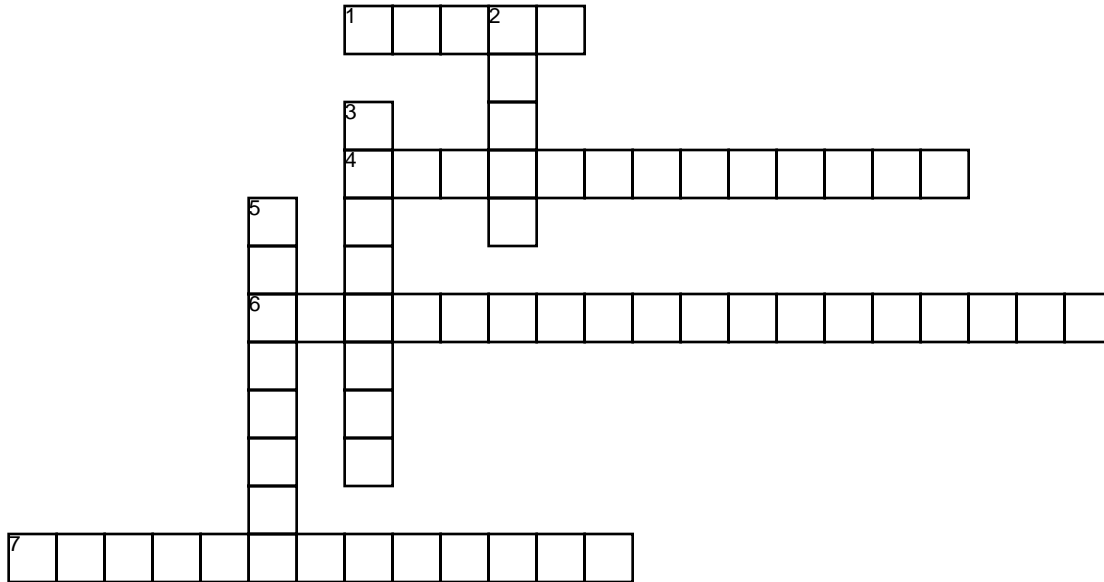

### ACROSS

1. The device that connects the computer and the phone system together and allows them to interface
4. A commercial service that allows the user to connect via computer to access information share software files send and receive
6. The method of communicating over long distances; using telephone lines with computers equipped with modems is one form of \_\_\_\_\_.
7. A place on an online service where users post messages and responses. (2 Words)

### DOWN

2. Electronic mail that is sent by a computer through the phonelines to another user or users.
3. The process of retrieving computer software or files through an online service and saving them to your disk drive.
5. A web of telecommunication computer networks that are linked together to allow the user to access information.

Name \_\_\_\_\_

## Aerial Photographic Interpretation

Name of Model Rocket Series: **Beta**

Name of Model Rocket: **Astrocam® 110**

To calculate the altitude at apogee, use the following formula:

$$\text{Altitude} = \text{Baseline} \times \text{Tangent of Angular Distance}$$

Photo Frame Number	Baseline Distance	Angular Distance	Tangent of Angular Distance	Calculated Altitude at Apogee	Special Notes
1					
2					
3					
4					
5					
6					
7					
8					
9					
10					
11					
12					
13					
14					
15					
16					
17					
18					
19					
20					
21					
22					
23					
24					

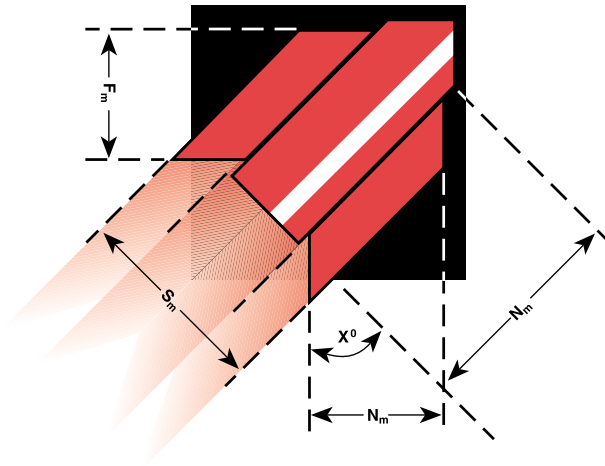

**ESTES**  
**EDUCATOR™**

## OVERHEAD TRANSPARENCIES



© 1995, 1999 Centuri Corporation.  
All rights reserved.

# FORCES THAT ACT ON OBJECTS MOVING THRU THE AIR

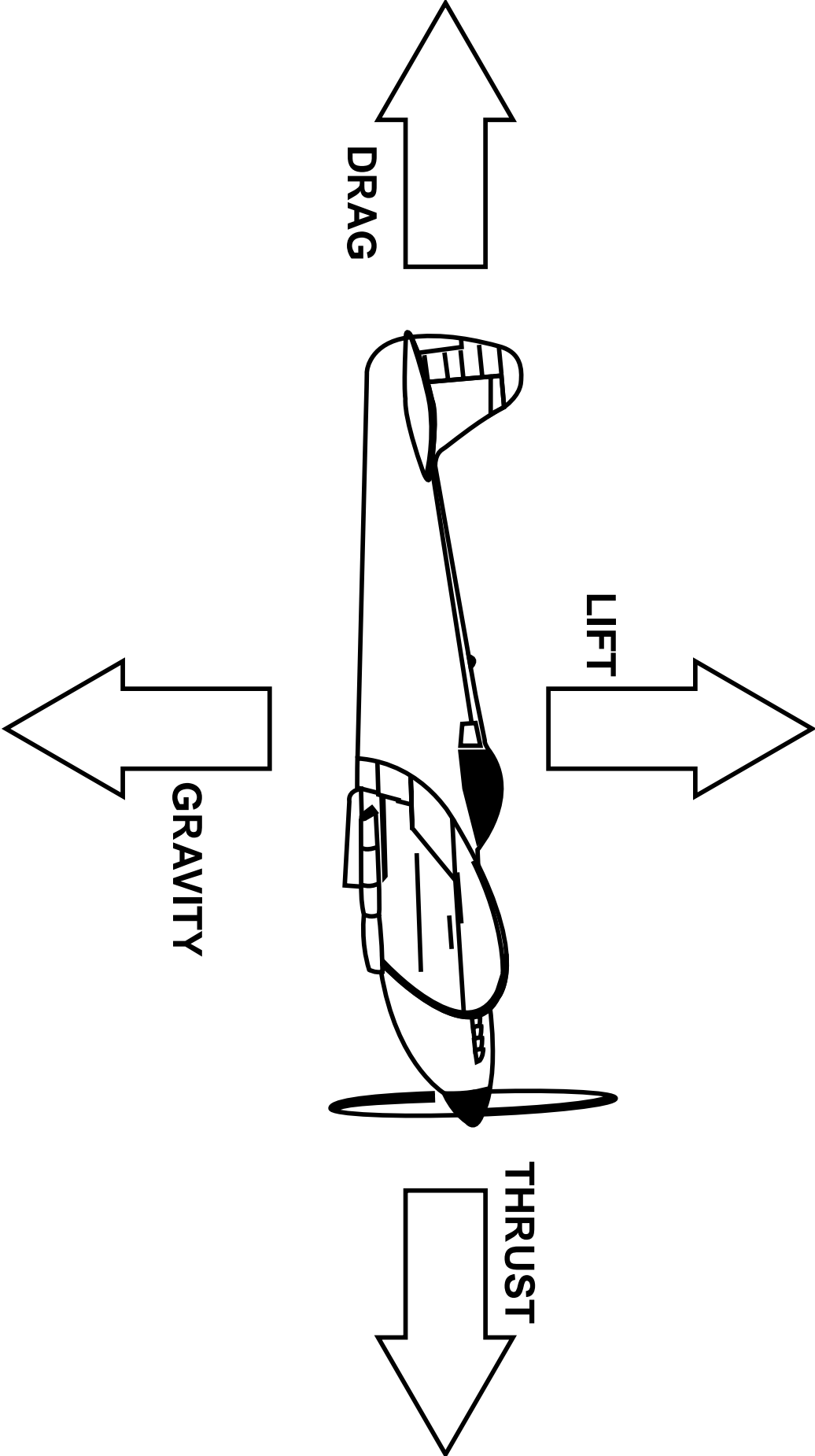



# NEWTON'S FIRST LAW OF MOTION

Objects at rest will stay at rest, and objects in motion will stay in motion in a straight line at constant velocity, unless acted upon by an unbalanced force.

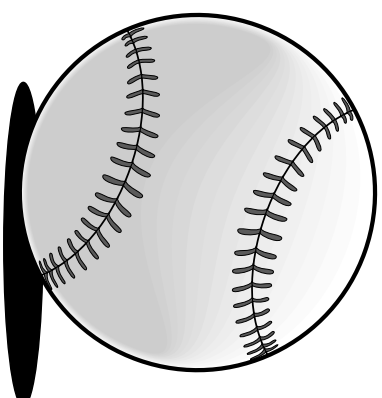

---

---

---

---

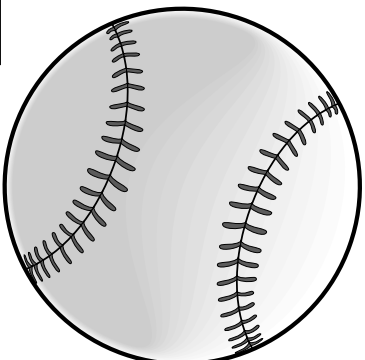

TR2.1B

# NEWTON'S SECOND LAW OF MOTION

Force is equal to mass times acceleration.

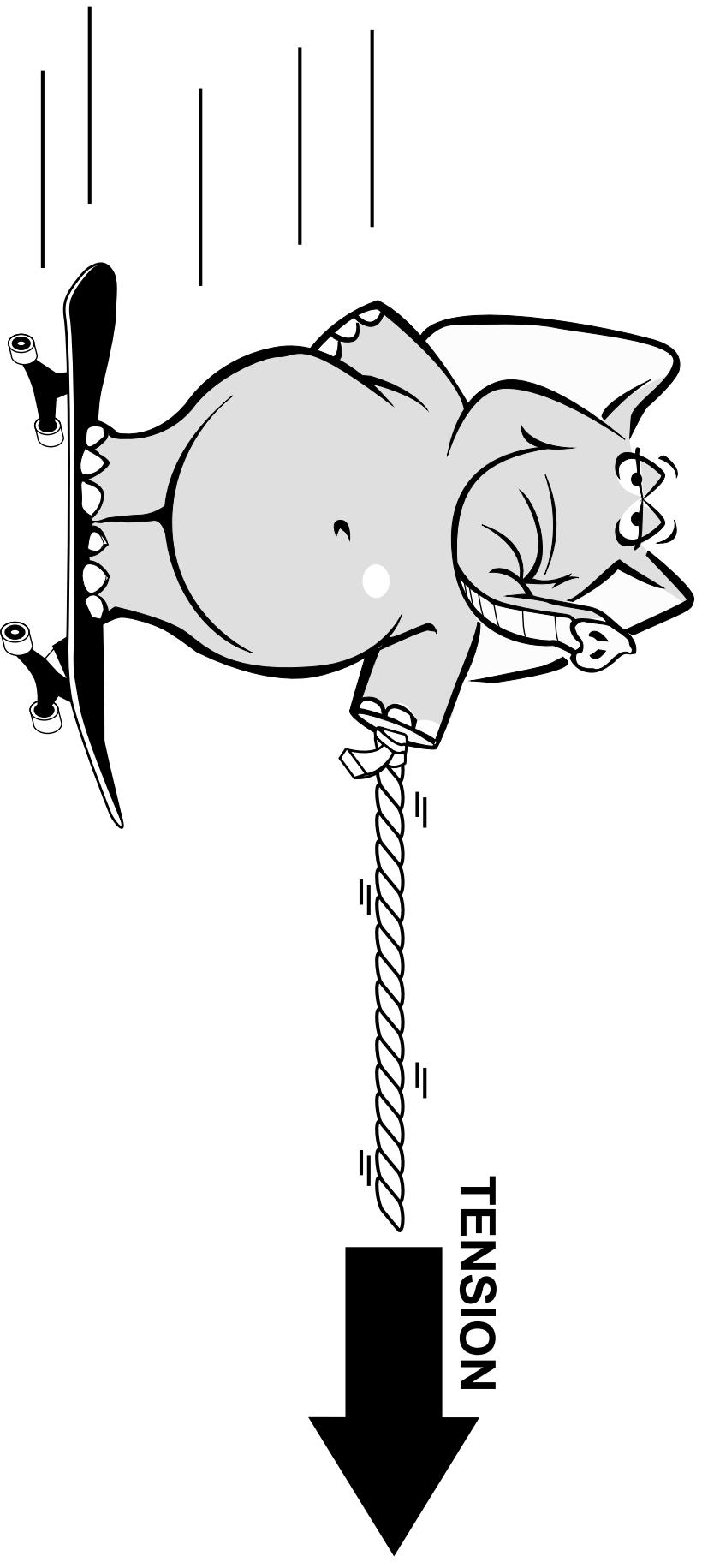

# NEWTON'S THIRD LAW OF MOTION

For every action there is an opposite and equal reaction.

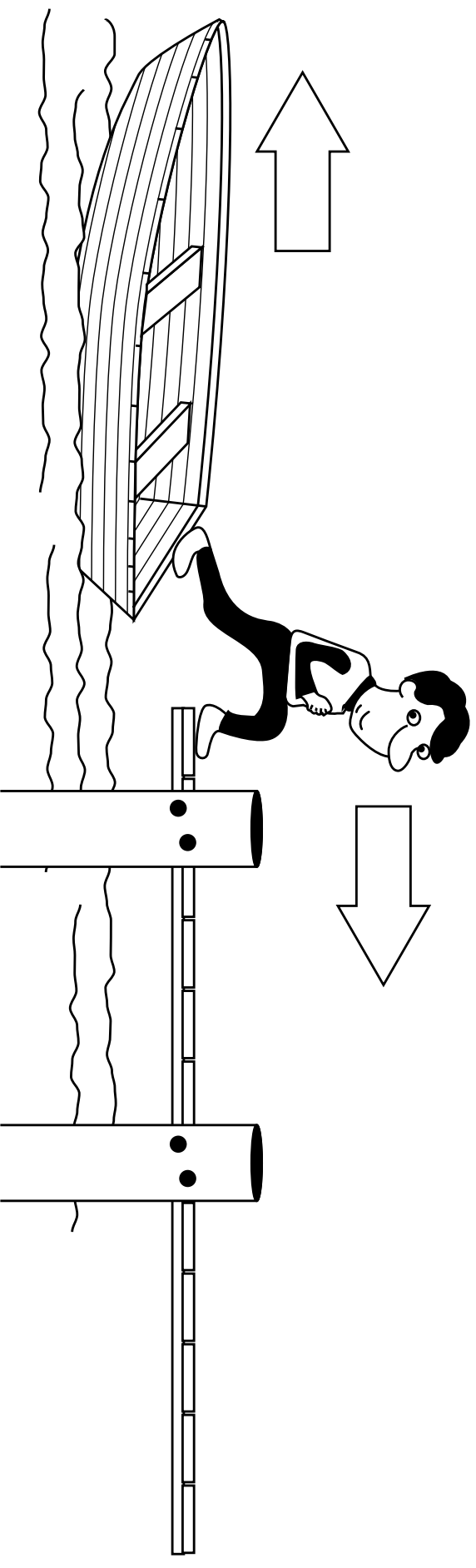

# COMMON FIN SHAPES

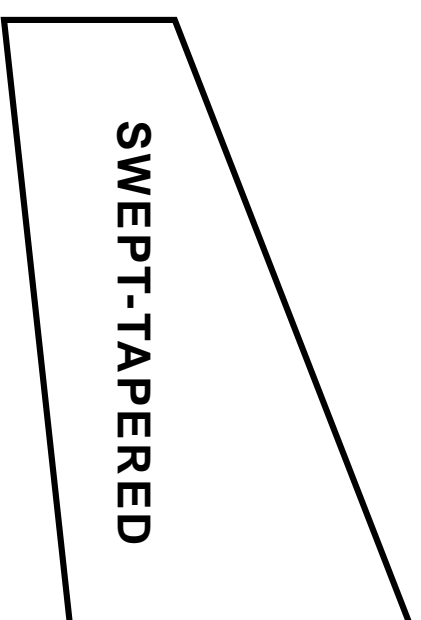
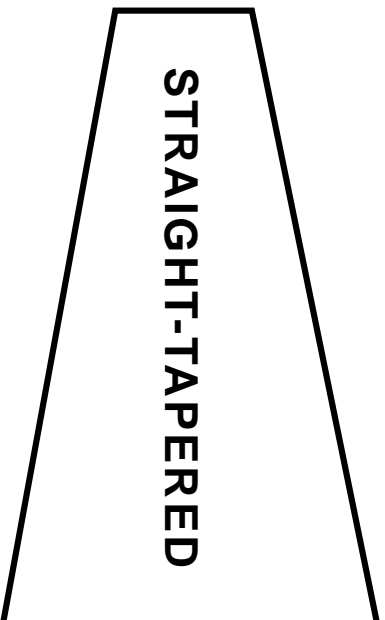
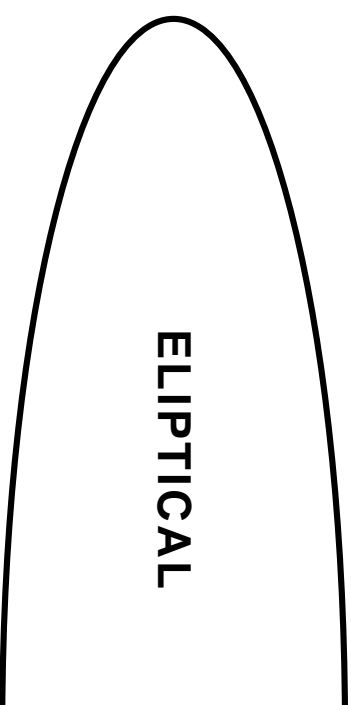
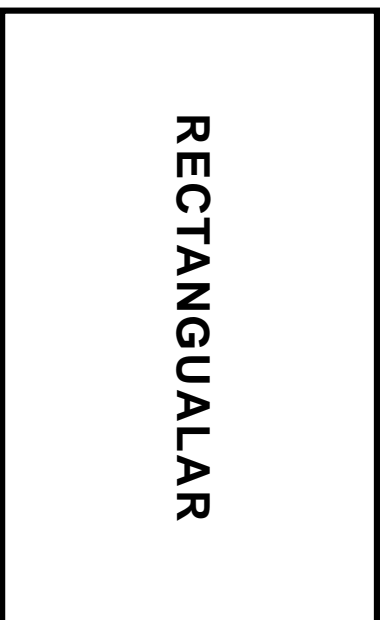

# PARTS OF A FIN

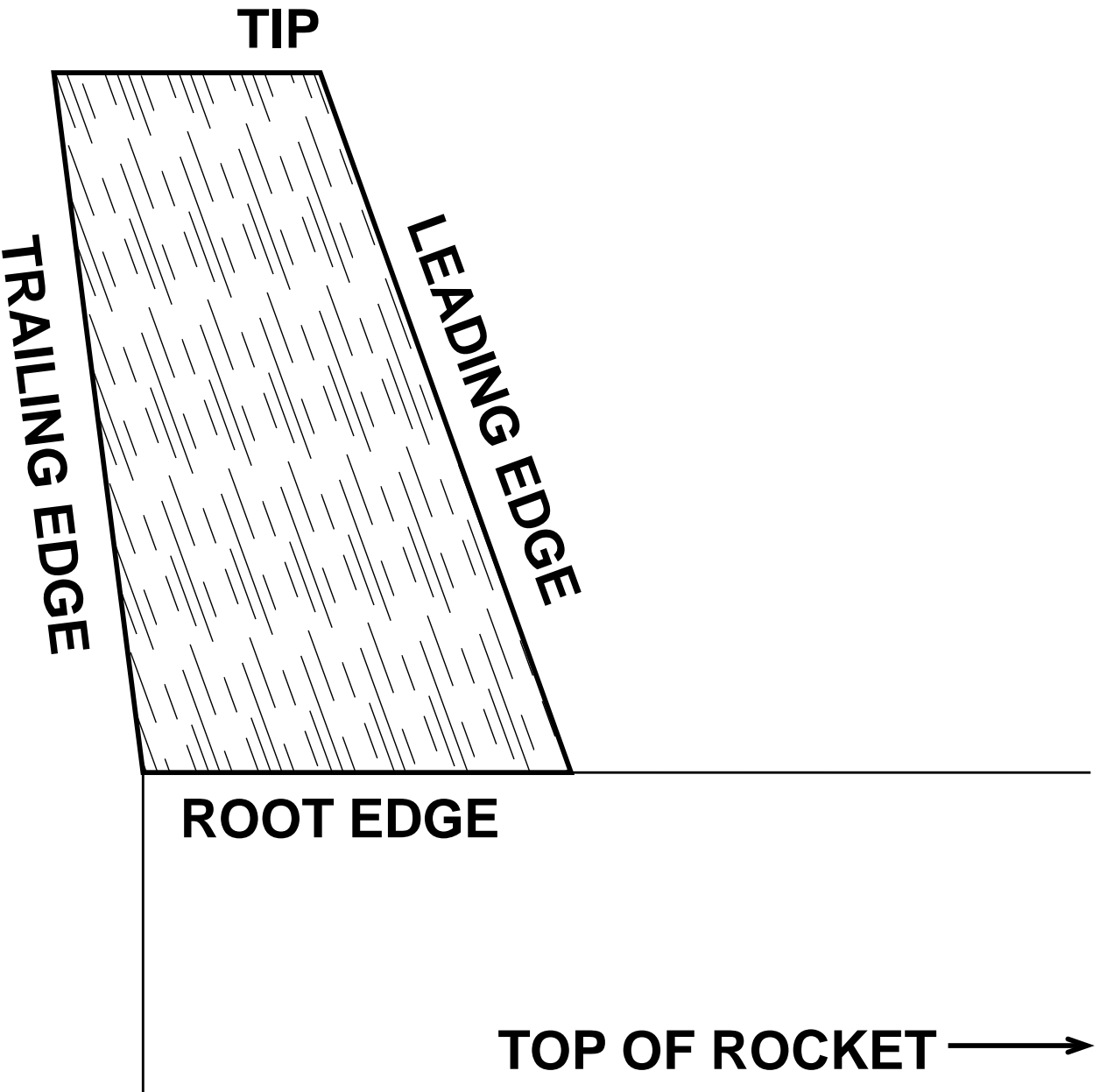

TR2.2B

# WHAT IS DRAG?

Wind against palm of hand results in a greater drag

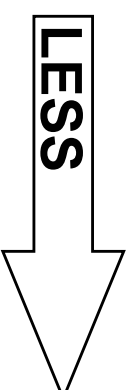
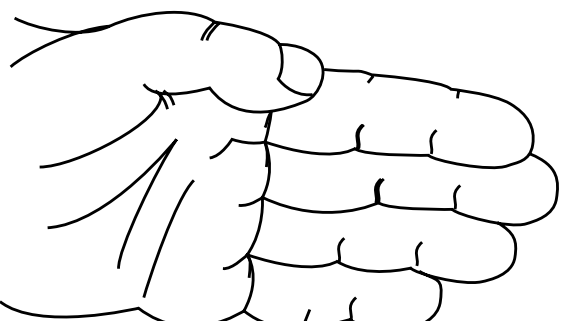
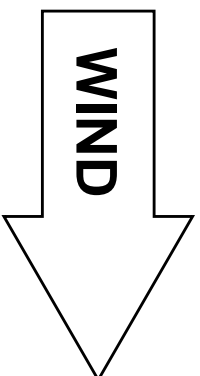
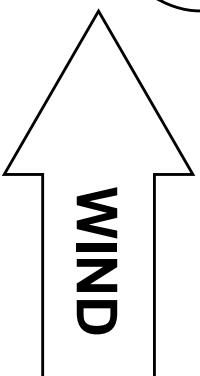
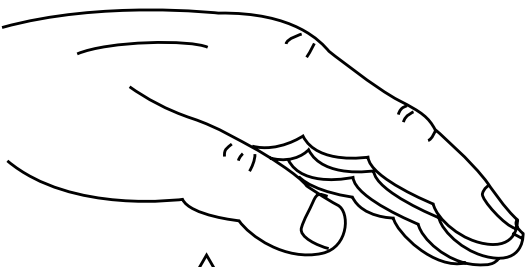
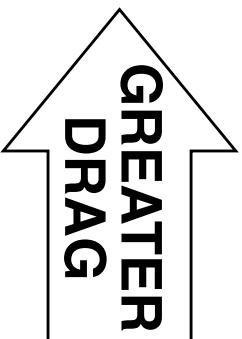

Wind against edges of hand results in less drag

# FIN SHAPING TECHNIQUES

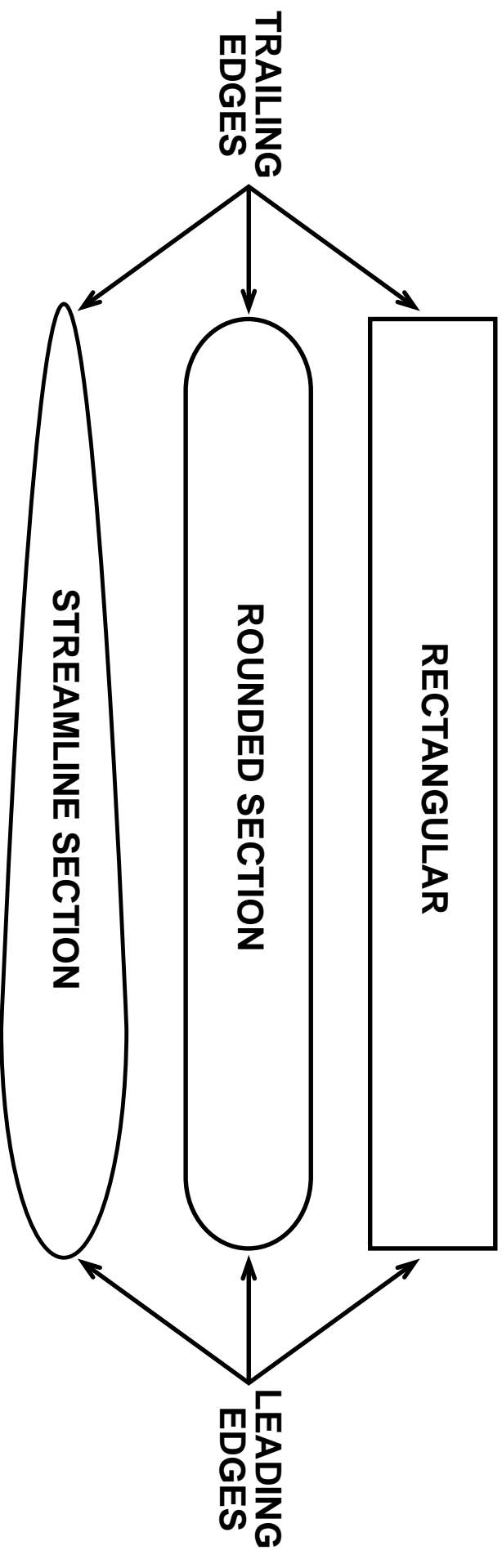

# FIN WORKMANSHIP

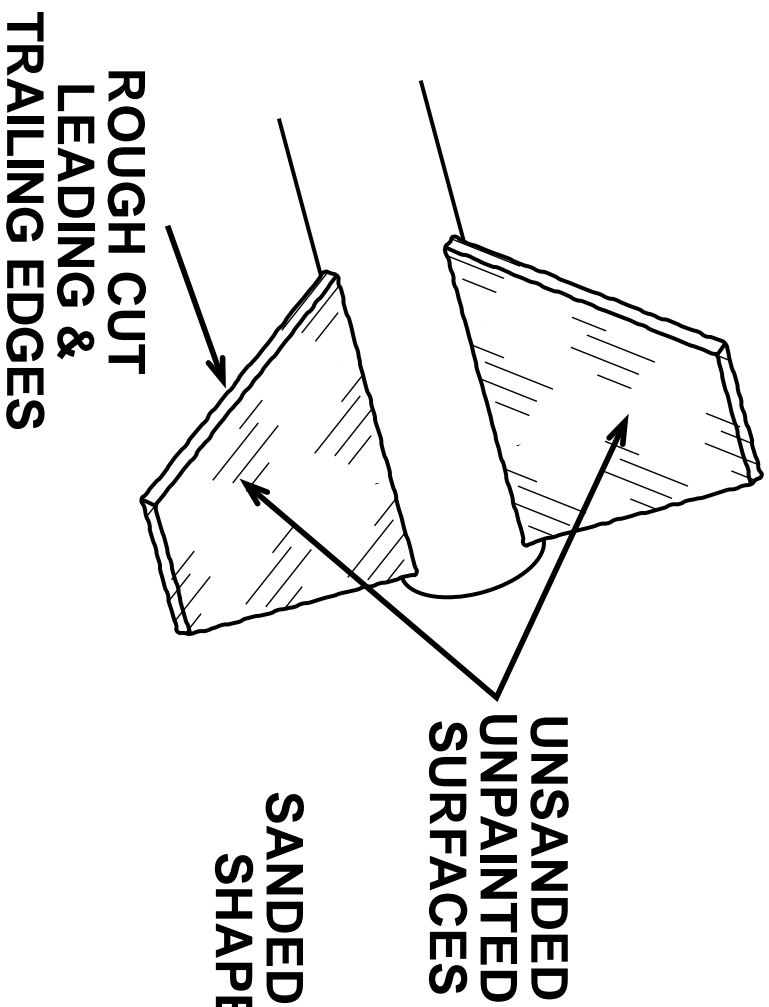

AMATEUR

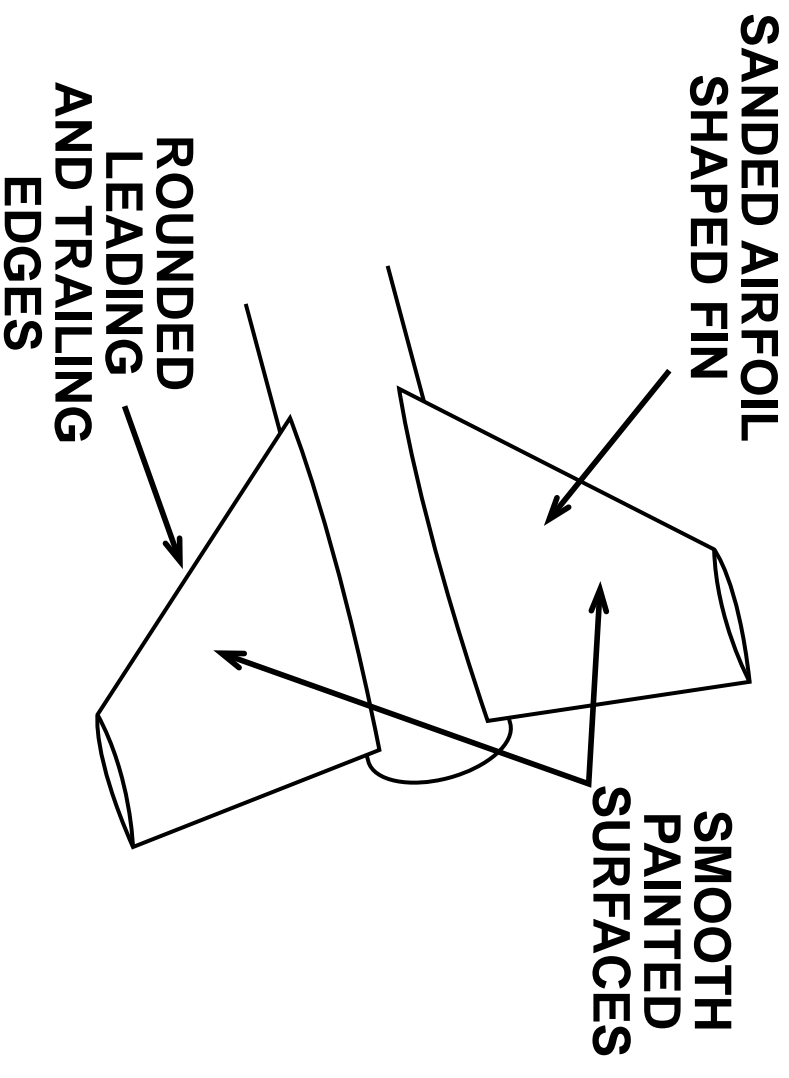

PROFESSIONAL



# NOSE CONE SHAPES

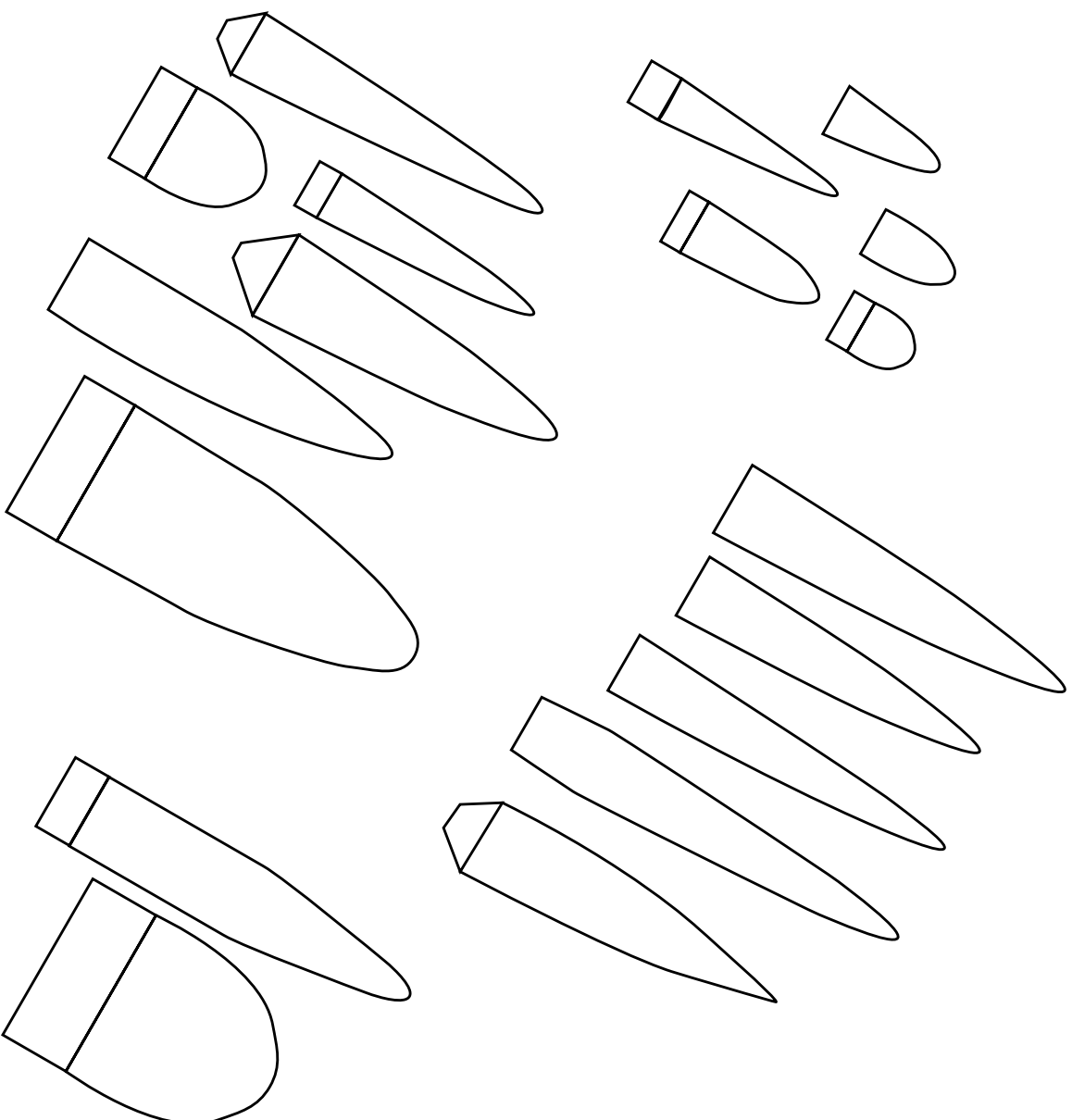

TR2.3A

# PRESSURE DRAG

**EQUAL PRESSURE  
SURROUNDS BALL**

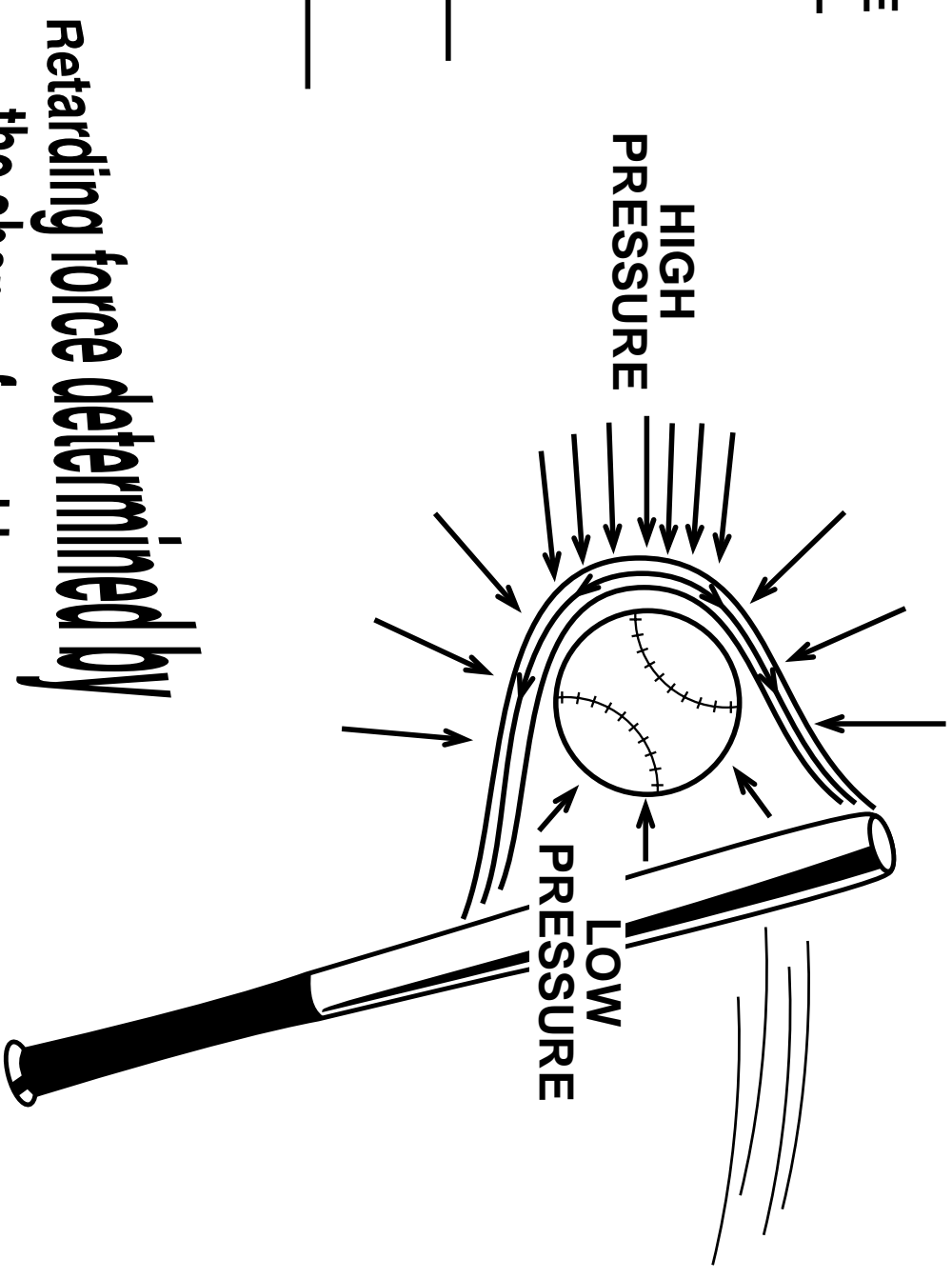
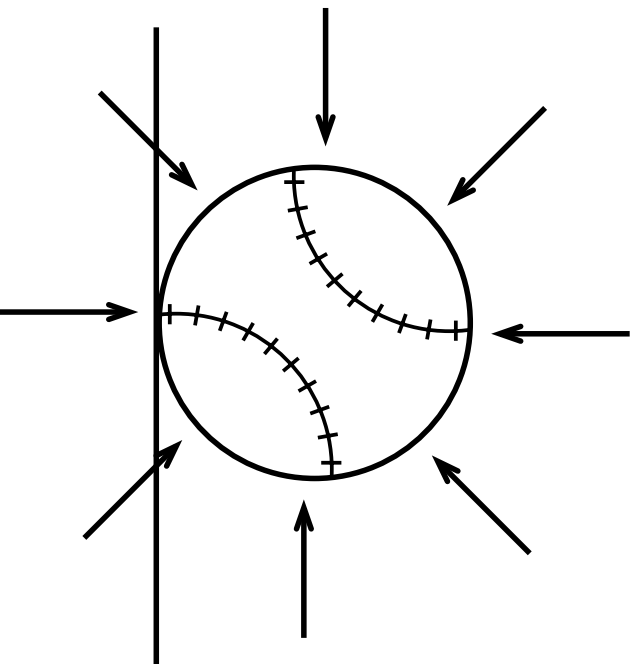

**Retarding force determined by  
the shape of an object**

# FRICTION DRAG

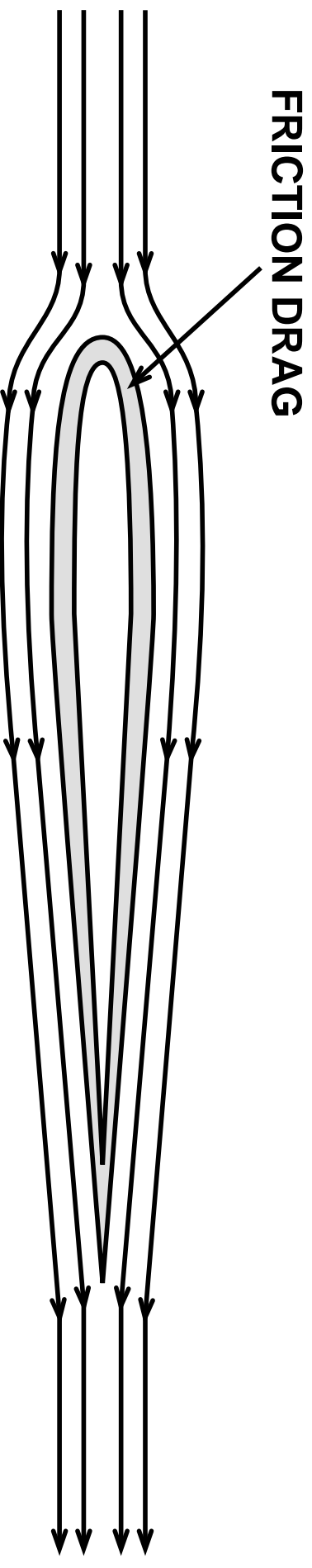

***Resistance between a fluid and  
the surface of a moving object***

# REDUCING DRAG IN PARACHUTE RECOVERY SYSTEMS

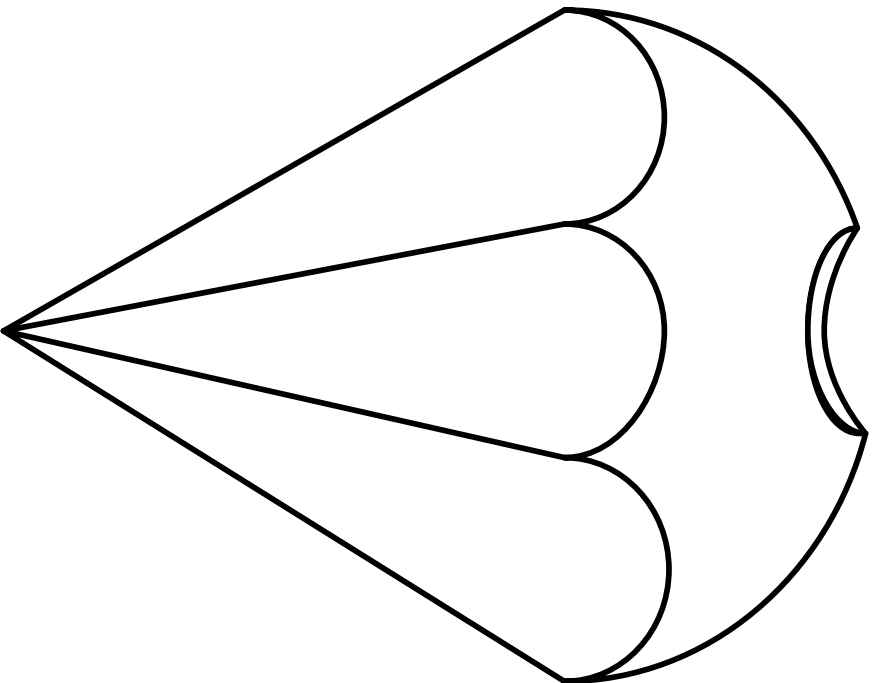

CUTTING HOLE IN  
CENTER OF PARACHUTE

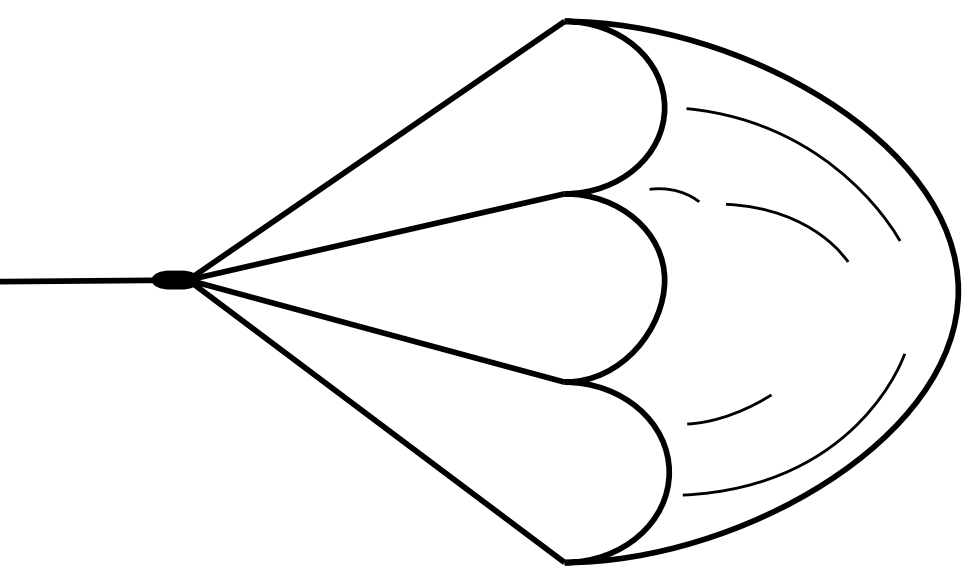

SHORTENING SHROUD  
LINES

# PARTS OF A MODEL ROCKET

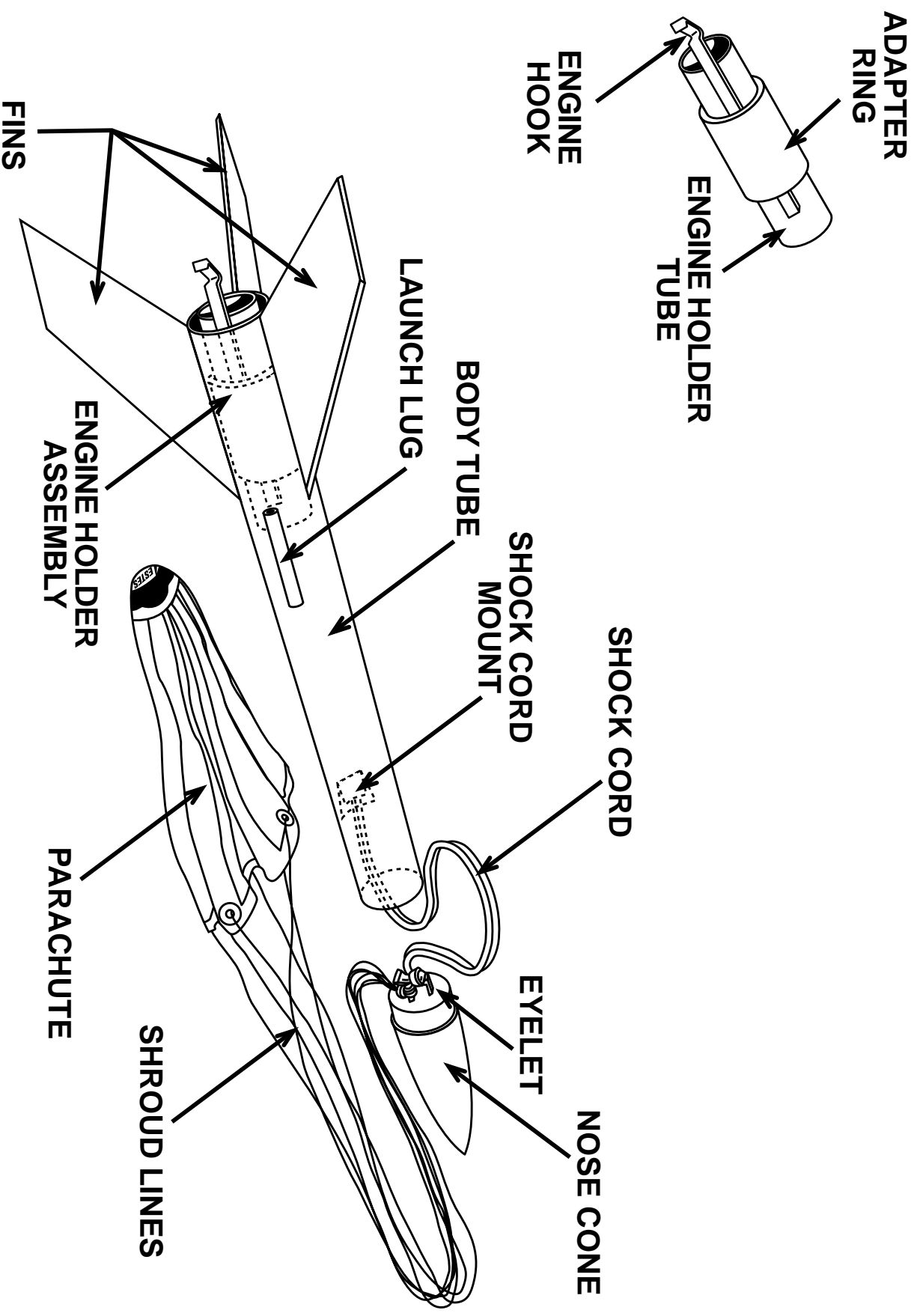

# FIN ALIGNMENT PROBLEMS

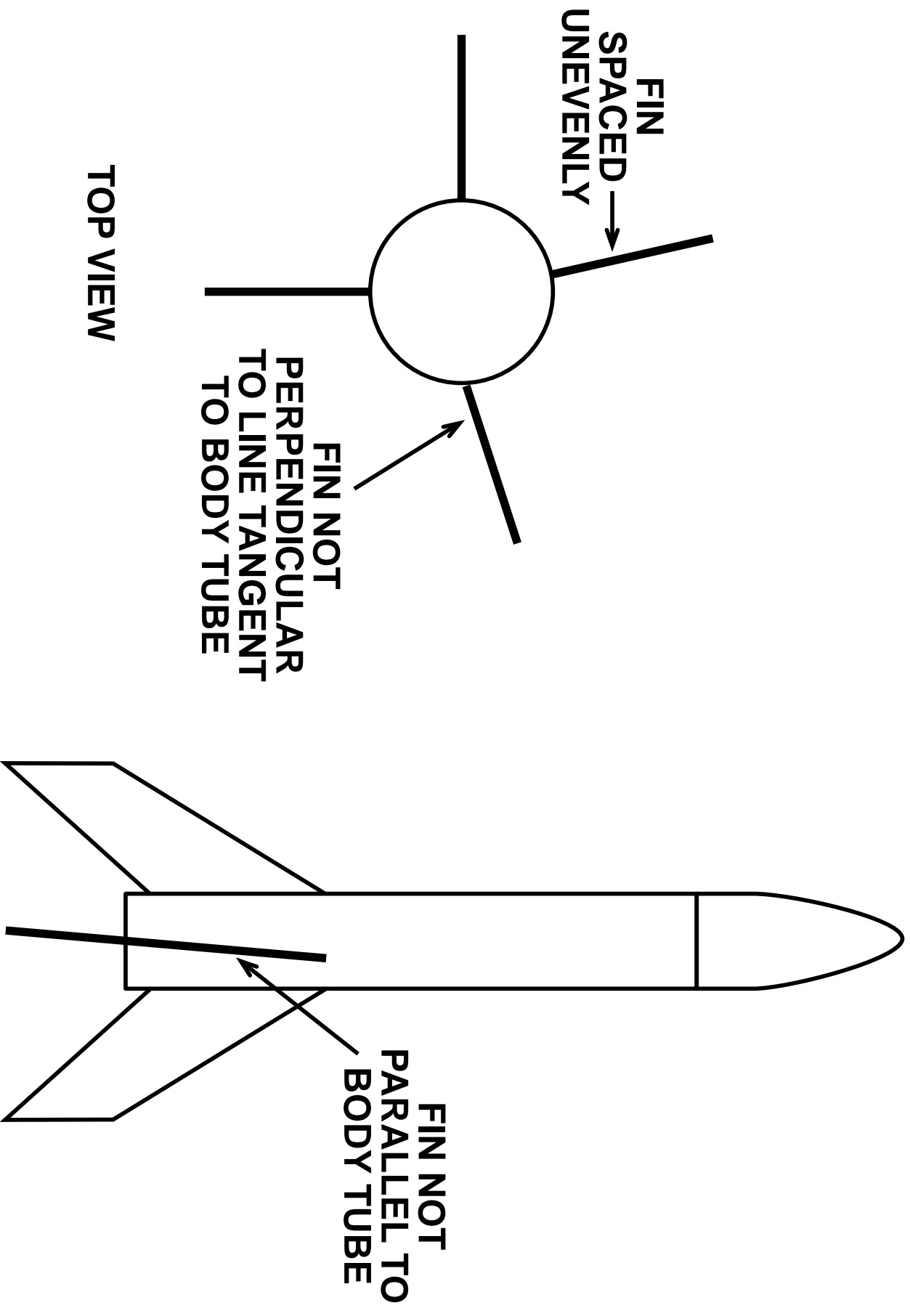

# PARTS OF A PACKAGE

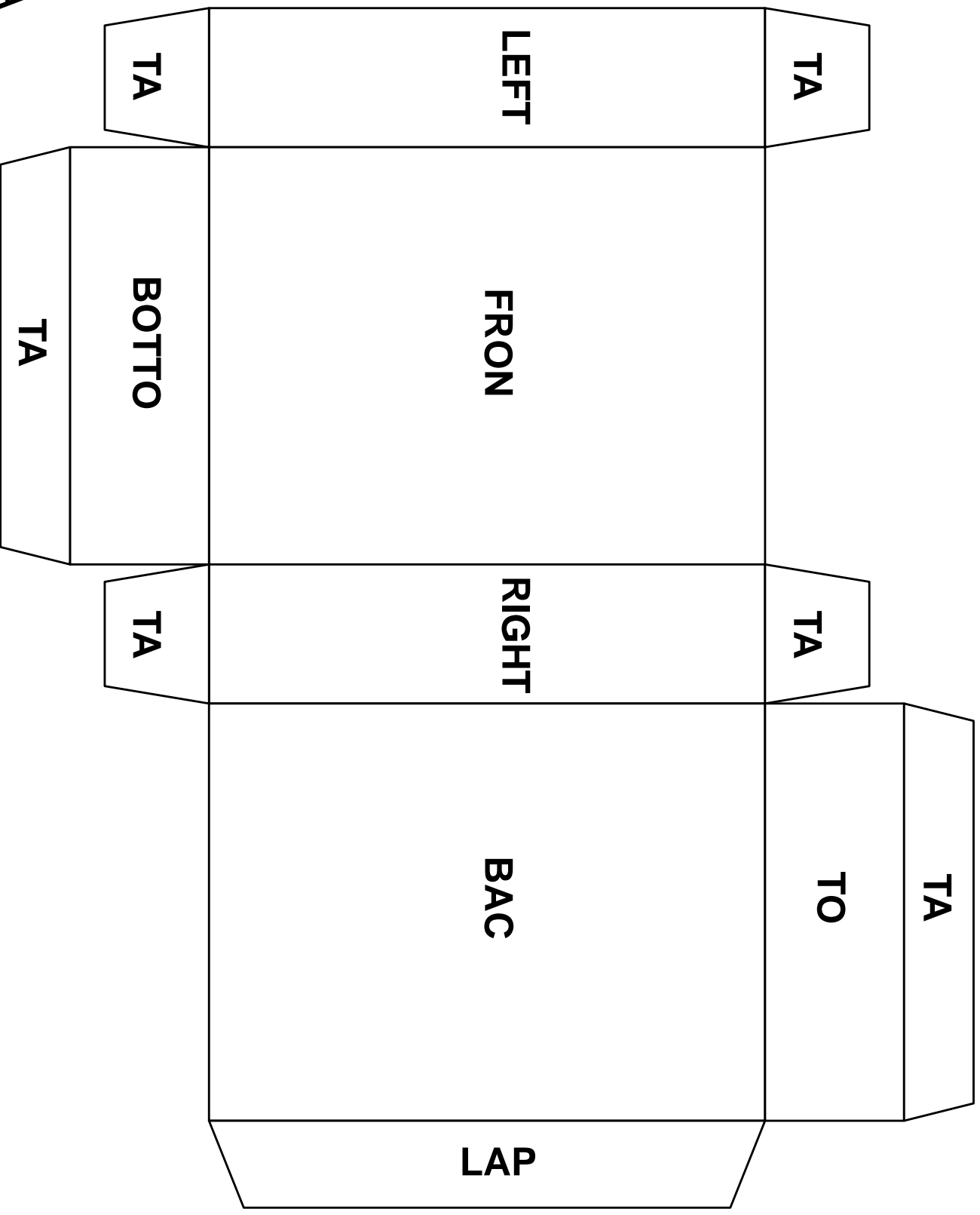

TR4.3A

# FLOWCHART SYMBOLS

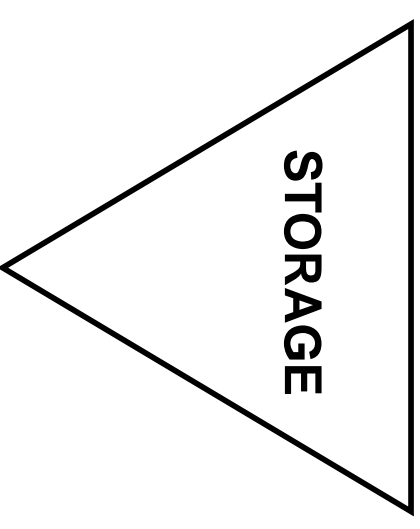
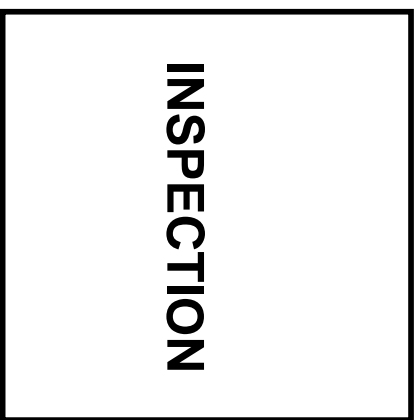
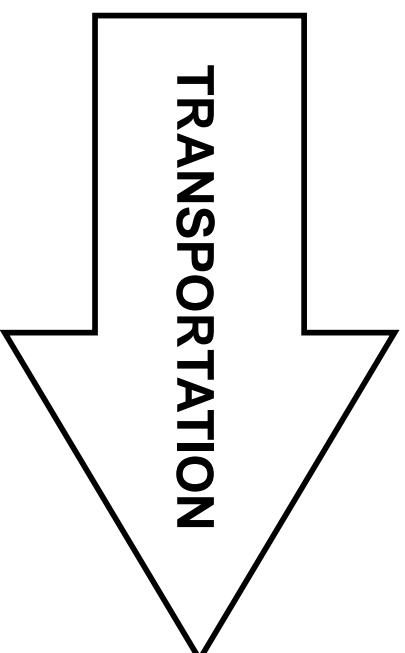



# MODEL ROCKET ENGINE CUTAWAY

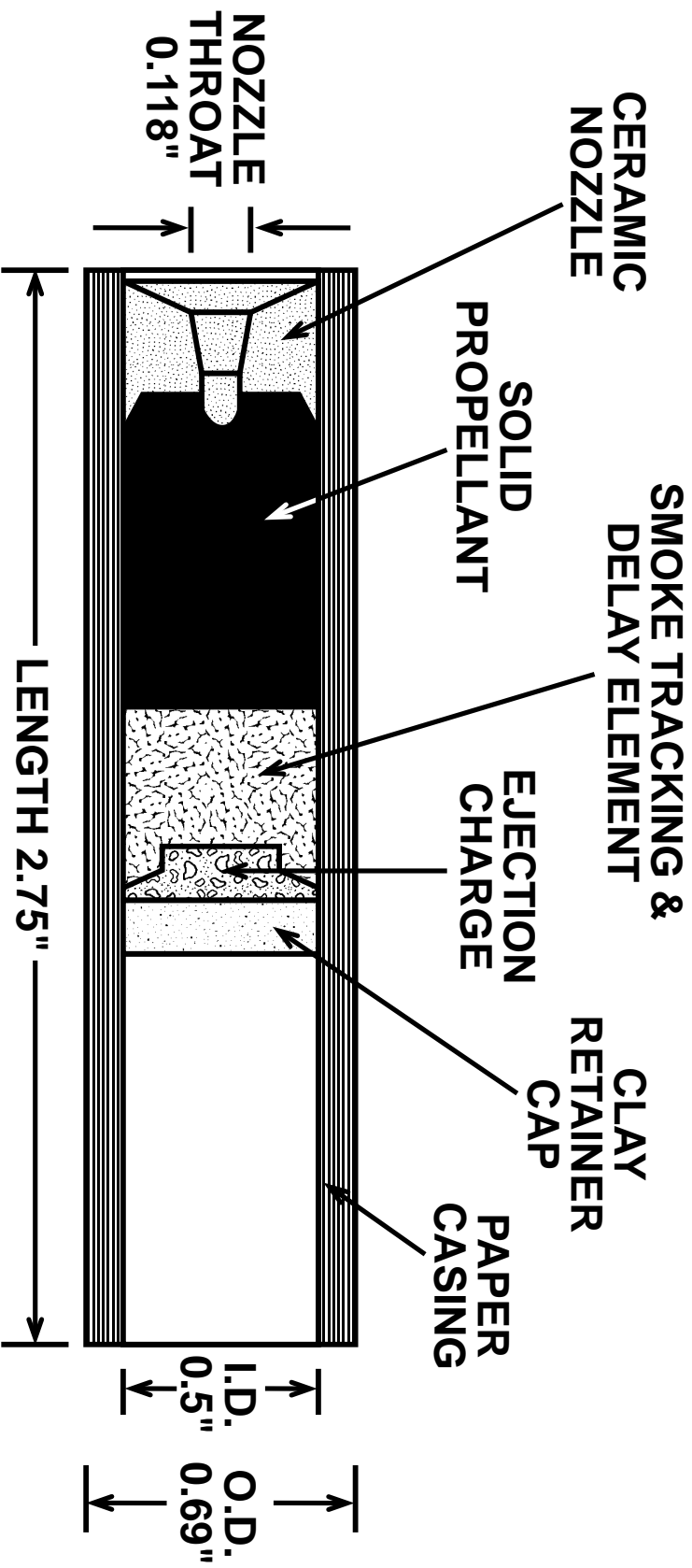

TR5.1

## B6-4 ENGINE

# NAR Model Rocketry Safety Code

The safety code was formulated by experienced rocketeers and has evolved with model rocketry. It should be followed in every model rocketry activity.

- 1. Materials** - My model rocket will be made of lightweight materials such as paper, wood, rubber, and plastic suitable for the power used and the performance of my model rocket. I will not use any metal for the nose cone, body, or fins of my model rocket.
- 2. Engines/Motors** - I will use only commercially-made NAR certified model rocket engines in the manner recommended by the manufacturer. I will not alter the model rocket engine, its parts, or its ingredients in any way.
- 3. Recovery** - I will always use a recovery system in my model rocket that will return it safely to the ground so that it may be flown again. I will use only flame resistance recovery wadding if required.
- 4. Weight and Power Limits** - My model rocket will weigh no more than 1,500 grams (53 ounces) at liftoff, and its rocket engines will produce no more than 320 newton-seconds (4.45 newtons equal 1.0 pound) of total impulse. My model rocket will weigh no more than the engine manufacturer's recommended maximum liftoff weight for the engines used, or I will use engines recommended by the manufacturer for my model rocket.

**5. Stability** - I will check the stability of my model rocket before its first flight, except when launching a model rocket of already proven stability.

**6. Payloads** - Except for insects, my model rocket will never carry live animals or a payload that is intended to be flammable, explosive, or harmful.

**7. Launch Site** - I will launch my model rocket outdoors in a cleared area, free of tall trees, power lines, buildings, and dry brush and grass. My launch site will be at least as large as that recommended in the following table:

### **LAUNCH SITE DIMENSIONS**

<b>Engines</b>	<b>Site Diameter</b>		<b>Estes Recommended Maximum Altitude</b>	
	<b>Feet</b>	<b>Meters</b>	<b>Feet</b>	<b>Meters</b>
1/2 A	50	15	200	61
A	100	30	400	122
B	200	60	800	244
C	400	120	1600	488
D	500	150	1800	549

Minimum launch site in dimension for a circular area is diameter in feet/meters and for rectangular area is shortest side in feet/meters.

**8. Launcher** - I will launch my model rocket from a stable launching device that provides rigid guidance until the model rocket has reached a speed adequate to ensure a safe flight path. To prevent accidental eye injury, I will always place the launcher so that the end of the rod is above eye level or I will cap the end of the rod when approaching it. I will cap or disassemble my launch rod when not in use and I will never store it in an upright position. My launcher will have a jet deflector device to prevent the engine exhaust from hitting the ground directly. I will always clear the area around my launch device of brown grass, dry weeds, and other easy-to-burn materials.

**9. Ignition System** - The system I will use to launch my model rocket will be remotely controlled and electrically operated. It will contain a launching switch that will return to “off” when released. The system will contain a removable safety interlock in series with the launch switch. All persons will remain at least 15 feet (5 meters) from the model rocket when I am igniting model rocket engines totaling 30 newton-seconds or less of total impulse and at least 30 feet (9 meters) from the model rocket when I am igniting model rocket engines totaling more than 30 newton-seconds of total impulse. I will use only electrical igniters recommended by the engine manufacturer that will ignite model rocket engine(s) within one second of actuation of the launching switch.

**10. Launch Safety** - I will ensure that people in the launch area are aware of the pending model rocket launch and can see the model rocket’s liftoff before I begin my audible five-second countdown. I will not launch a model rocket using it as a weapon. If my model

rocket suffers a misfire, I will not allow anyone to approach it or the launcher until I have made certain that the safety interlock has been removed or that the battery has been disconnected from the ignition system. I will wait one minute after a misfire before allowing anyone to approach the launcher.

**11. Flying Conditions** - I will launch my model rocket only when the wind is less than 20 miles (30 kilometers) an hour. I will not launch my model rocket so it flies into clouds, near aircraft in flight, or in a manner that is hazardous to people or property.

**12. Pre-Launch Test** - When conducting research activities with unproven model rocket designs or methods I will, when possible, determine the reliability of my model rocket by pre-launch tests. I will conduct the launching of an unproven design in complete isolation from persons not participating in the actual launching.

**13. Launch Angle** - My launch device will be pointed within 30 degrees of vertical. I will never use model rocket engines to propel any device horizontally.

**14. Recovery Hazards** - If a model rocket becomes entangle in a power line or other dangerous place, I will not attempt to retrieve it.

This is the official Model Rocketry Safety Code of the National Association of Rocketry and Model Rocket Manufacturers Association.

The largest legal “model” rocket engine, as defined by CPSC, is an “F” (80NS) engine. To launch rockets weighing over one pound including propellant or rockets containing more than 4.4 ounces (net weight) of propellant, you need to obtain a waiver from the FAA. Check your telephone directory for the FAA office nearest you.

# FLIGHT DATA SHEET



Model Rocket

## FLIGHT DATA SHEET

PUBLISHED AS A SERVICE TO ITS CUSTOMERS BY  
ESTES INDUSTRIES, PENROSE, COLORADO 81240  
© ESTES INDUSTRIES 1993

NAME \_\_\_\_\_  
ADDRESS \_\_\_\_\_  
CITY \_\_\_\_\_ STATE \_\_\_\_\_ ZIP \_\_\_\_\_

USE ONE FLIGHT DATA SHEET FOR EACH MODEL.  
FOUR FLIGHTS MAY BE RECORDED ON EACH SHEET.

### PREFLIGHT INFORMATION

Rocket Name \_\_\_\_\_ Nose Cone Type \_\_\_\_\_  
Rocket Number \_\_\_\_\_ Fin Type \_\_\_\_\_  
Date Completed \_\_\_\_\_ No. of Fins \_\_\_\_\_  
Type of Rocket \_\_\_\_\_ Color Scheme \_\_\_\_\_  
No. of Stages \_\_\_\_\_ Weight Empty \_\_\_\_\_

### COUNTDOWN CHECKLIST\*

Parachute or Streamer Recovery	Feather-weight, break-apart, or Helicopter Recovery	Glide Recovery
<input type="checkbox"/> <input type="checkbox"/> <input type="checkbox"/> <input type="checkbox"/> 12) Pack flame resistant recovery wadding into the body tube, insert the parachute or streamer. <input type="checkbox"/> <input type="checkbox"/> <input type="checkbox"/> <input type="checkbox"/> 11) Install the nose cone or payload section. Check for proper fit and load (if any). <input type="checkbox"/> <input type="checkbox"/> <input type="checkbox"/> <input type="checkbox"/> 10) If not equipped with an engine hook, apply masking tape to the engine(s) to achieve a tight friction fit in the body tube(s). Secure with engine hook, if used. When launching a multi-stage rocket, be sure that the engine are in their proper relative positions and that a layer of separate tape is wrapped tightly around each engine joint. <input type="checkbox"/> <input type="checkbox"/> <input type="checkbox"/> <input type="checkbox"/> 9) Install a lighter plug. <input type="checkbox"/> <input type="checkbox"/> <input type="checkbox"/> <input type="checkbox"/> 8) Place the rocket on the launcher. Clean and attach the micro-clips. <input type="checkbox"/> <input type="checkbox"/> <input type="checkbox"/> <input type="checkbox"/> 7) Clear the area. Check for low-flying aircraft and alert recovery crew and trackers. <input type="checkbox"/> <input type="checkbox"/> <input type="checkbox"/> <input type="checkbox"/> 6) Insert the safety key in controller. <input type="checkbox"/> <input type="checkbox"/> <input type="checkbox"/> <input type="checkbox"/> 5) Begin audible countdown. <input type="checkbox"/> <input type="checkbox"/> <input type="checkbox"/> <input type="checkbox"/> 4) <input type="checkbox"/> <input type="checkbox"/> <input type="checkbox"/> <input type="checkbox"/> 3) <input type="checkbox"/> <input type="checkbox"/> <input type="checkbox"/> <input type="checkbox"/> 2) <input type="checkbox"/> <input type="checkbox"/> <input type="checkbox"/> <input type="checkbox"/> 1) <input type="checkbox"/> <input type="checkbox"/> <input type="checkbox"/> <input type="checkbox"/> LAUNCH!	<input type="checkbox"/> <input type="checkbox"/> <input type="checkbox"/> <input type="checkbox"/> 10) Fit the engine in the body tube carefully so that the recovery system will function properly. Secure with engine hook, if used. <input type="checkbox"/> <input type="checkbox"/> <input type="checkbox"/> <input type="checkbox"/> 9) Install an lighter plug. <input type="checkbox"/> <input type="checkbox"/> <input type="checkbox"/> <input type="checkbox"/> 8) Place the rocket on the launcher. Clean and attach the micro-clips. <input type="checkbox"/> <input type="checkbox"/> <input type="checkbox"/> <input type="checkbox"/> 7) Clear the area. Check for low-flying aircraft and alert recovery crew and trackers. <input type="checkbox"/> <input type="checkbox"/> <input type="checkbox"/> <input type="checkbox"/> 6) Insert the safety key in controller. <input type="checkbox"/> <input type="checkbox"/> <input type="checkbox"/> <input type="checkbox"/> 5) Begin audible countdown. <input type="checkbox"/> <input type="checkbox"/> <input type="checkbox"/> <input type="checkbox"/> 4) <input type="checkbox"/> <input type="checkbox"/> <input type="checkbox"/> <input type="checkbox"/> 3) <input type="checkbox"/> <input type="checkbox"/> <input type="checkbox"/> <input type="checkbox"/> 2) <input type="checkbox"/> <input type="checkbox"/> <input type="checkbox"/> <input type="checkbox"/> 1) <input type="checkbox"/> <input type="checkbox"/> <input type="checkbox"/> <input type="checkbox"/> LAUNCH!	<input type="checkbox"/> <input type="checkbox"/> <input type="checkbox"/> <input type="checkbox"/> 12) Check booster recovery system, if separate from glider. <input type="checkbox"/> <input type="checkbox"/> <input type="checkbox"/> <input type="checkbox"/> 11) Set trim adjustments for desired flight path and for existing weather conditions. <input type="checkbox"/> <input type="checkbox"/> <input type="checkbox"/> <input type="checkbox"/> 10) Check engine for proper fit in body tube. Secure with engine hook, if used. <input type="checkbox"/> <input type="checkbox"/> <input type="checkbox"/> <input type="checkbox"/> 9) Install an lighter plug. <input type="checkbox"/> <input type="checkbox"/> <input type="checkbox"/> <input type="checkbox"/> 8) Place the rocket on the launcher. Clean and attach the micro-clips. <input type="checkbox"/> <input type="checkbox"/> <input type="checkbox"/> <input type="checkbox"/> 7) Clear the area. Check for low-flying aircraft and alert recovery crew and trackers. <input type="checkbox"/> <input type="checkbox"/> <input type="checkbox"/> <input type="checkbox"/> 6) Insert the safety key in controller. <input type="checkbox"/> <input type="checkbox"/> <input type="checkbox"/> <input type="checkbox"/> 5) Begin audible countdown. <input type="checkbox"/> <input type="checkbox"/> <input type="checkbox"/> <input type="checkbox"/> 4) <input type="checkbox"/> <input type="checkbox"/> <input type="checkbox"/> <input type="checkbox"/> 3) <input type="checkbox"/> <input type="checkbox"/> <input type="checkbox"/> <input type="checkbox"/> 2) <input type="checkbox"/> <input type="checkbox"/> <input type="checkbox"/> <input type="checkbox"/> 1) <input type="checkbox"/> <input type="checkbox"/> <input type="checkbox"/> <input type="checkbox"/> LAUNCH!

\*Helicopter recovery systems might use any of the three checklists depending on the specific rocket. Consult the instructions for the specific kit.

### LAUNCH

	Flight #1	Flight #2	Flight #3	Flight #4
Flight Number				
Date of Launch				
Launch Location				
Payload	Description			
	Weight			
Recovery System	Type			
	Color			
Engines:	1st Stage			
	2nd Stage			
	3rd Stage			
Total Weight				
Method of Launch				
Launch Angle				
Predicted Altitude				

### WEATHER

Wind Direction	
Wind Velocity	
Humidity	
Temperature	
Visibility	
Remarks	

### FLIGHT DATA

Estimated Altitude	
Tracking Information	
Computed Alt.	
Flight Duration	
Stability Information	
Flight Performance	

TR6.1B

# GRAPHICALLY DETERMINING HEIGHT

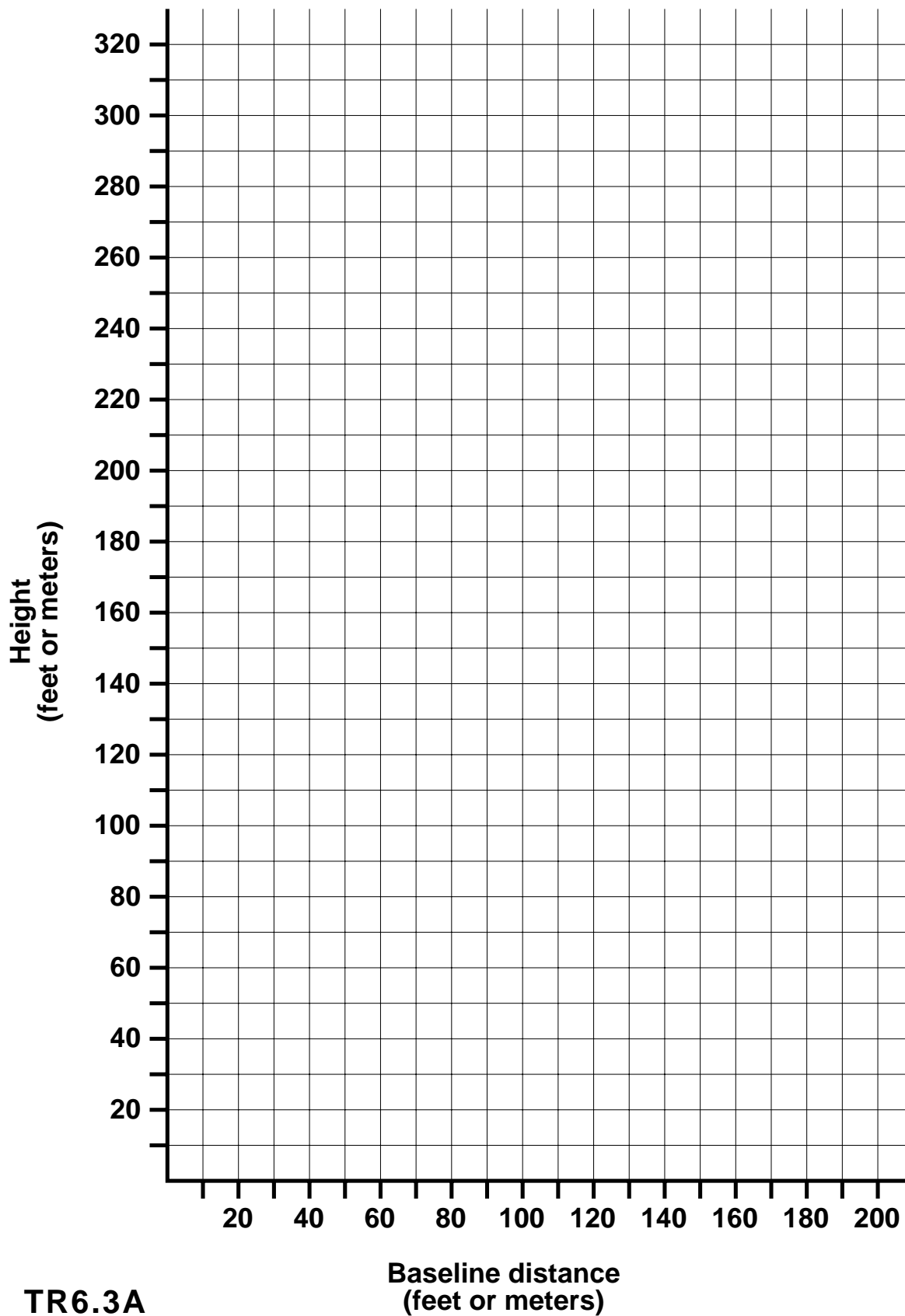

# GRAPHICALLY DETERMINING ALTITUDE OF MODEL ROCKET

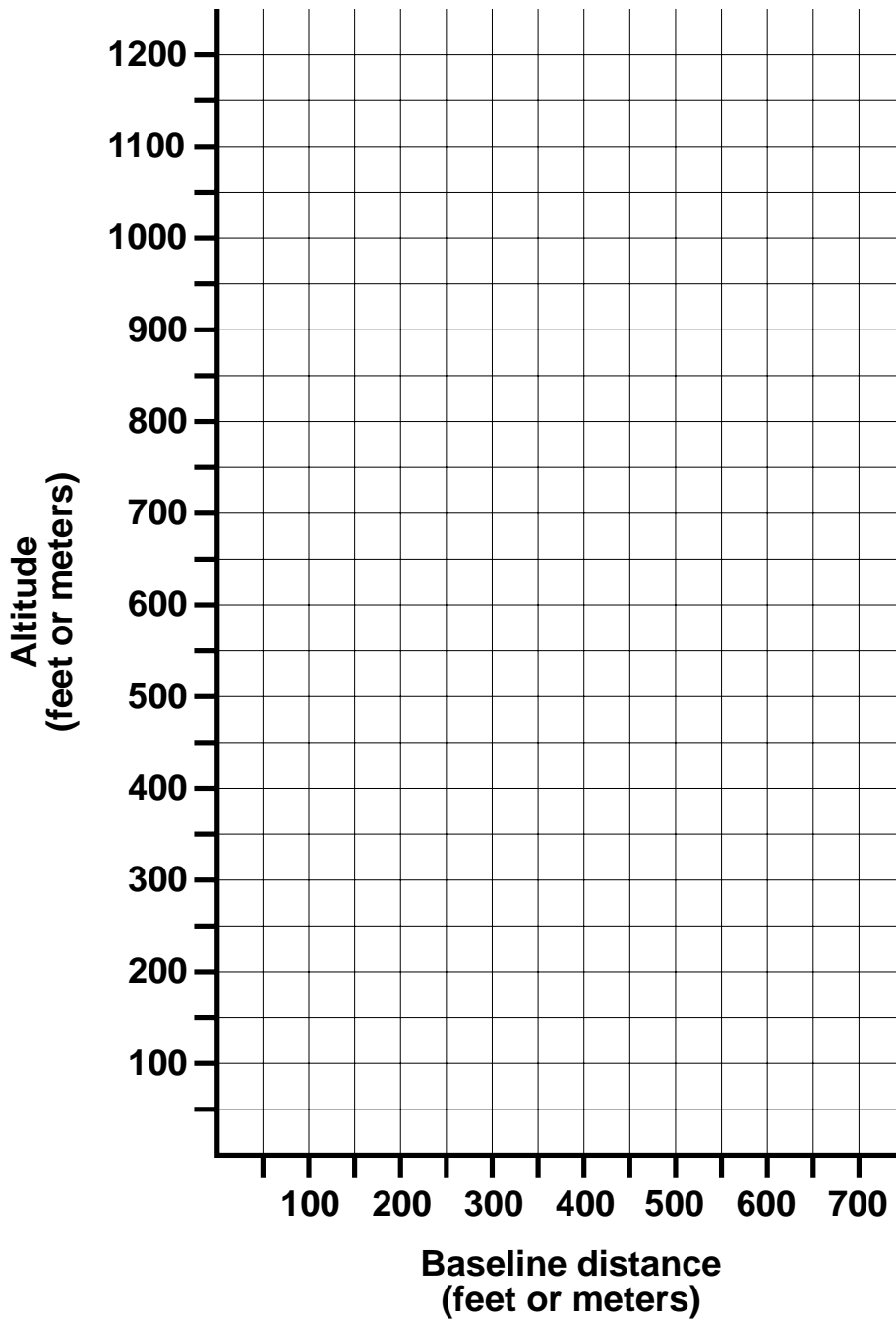

TR6.3B



# ALTITUDE TRACKING

**Baseline** - The distance from point A (tracking station) to point C (launch pad).

**Angular Distance** - Determined by measuring the angle between the rocket's position on the launch pad and the highest point reached by the rocket (point B) as seen by the tracking station or observer (point A).

**Height** - Distance from point C to point B.

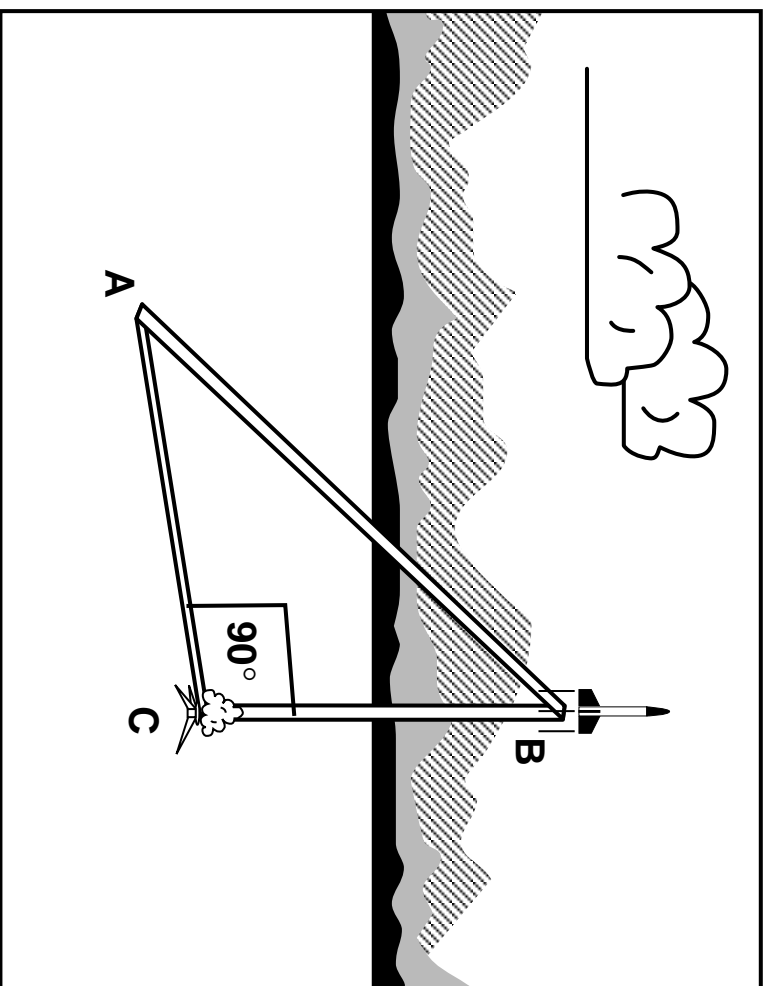

**HEIGHT = TANGENT OF ANGULAR DISTANCE x BASELINE**

**Example:**

Baseline = 450 feet

Angular distance =  $53^\circ$

Tangent of angular distance = .80

Height =  $.80 \times 450$  feet

Height = 360 feet

# MODEL ROCKET ENGINE CODING

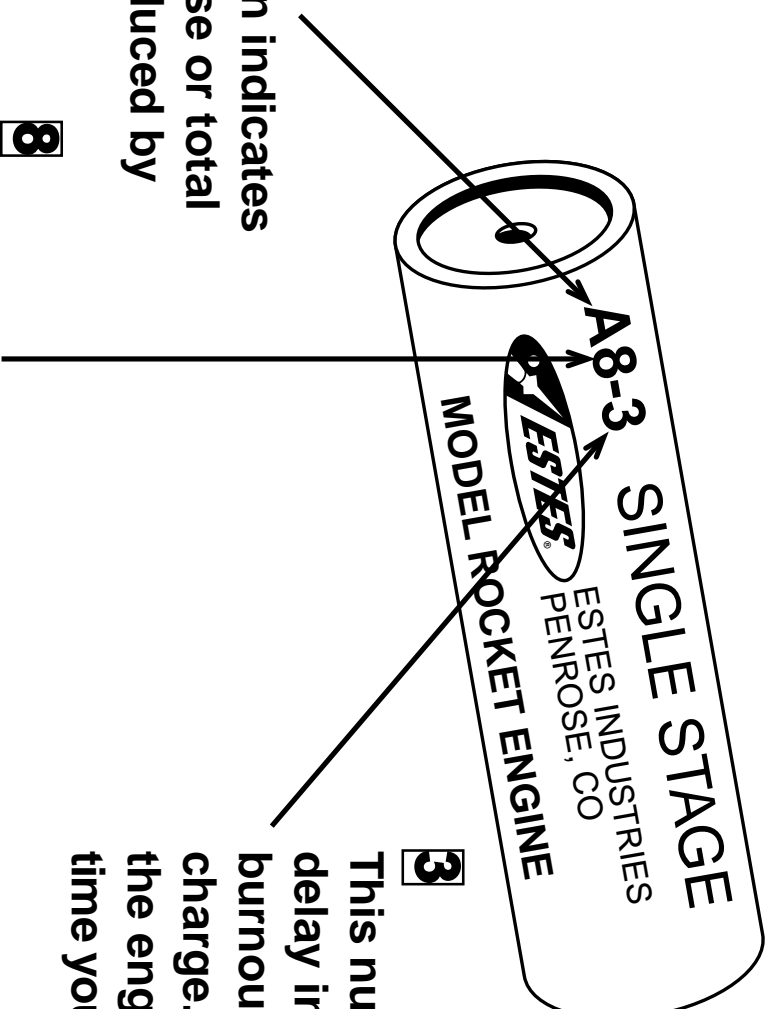

**A** This portion indicates total impulse or total power produced by the engine.

**8** This portion shows the engine's average thrust in newtons and helps you choose the right engine for your rocket's flight.

**3** This number gives you the delay in seconds between burnout and ejection charge. Lets you choose the engine with the delay time you want for any flight.

# MODEL ROCKET ENGINE CUTAWAY

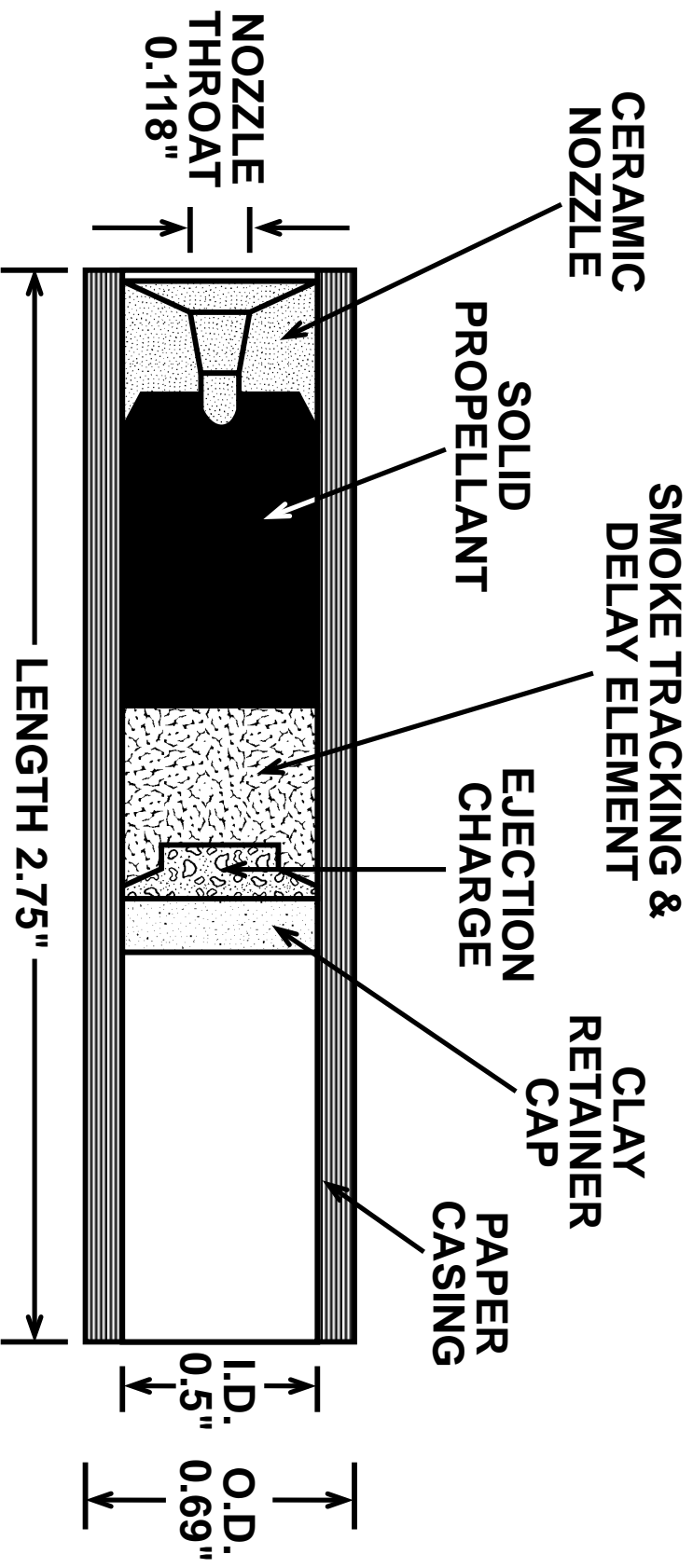

## B6-4 ENGINE

TR7.1B

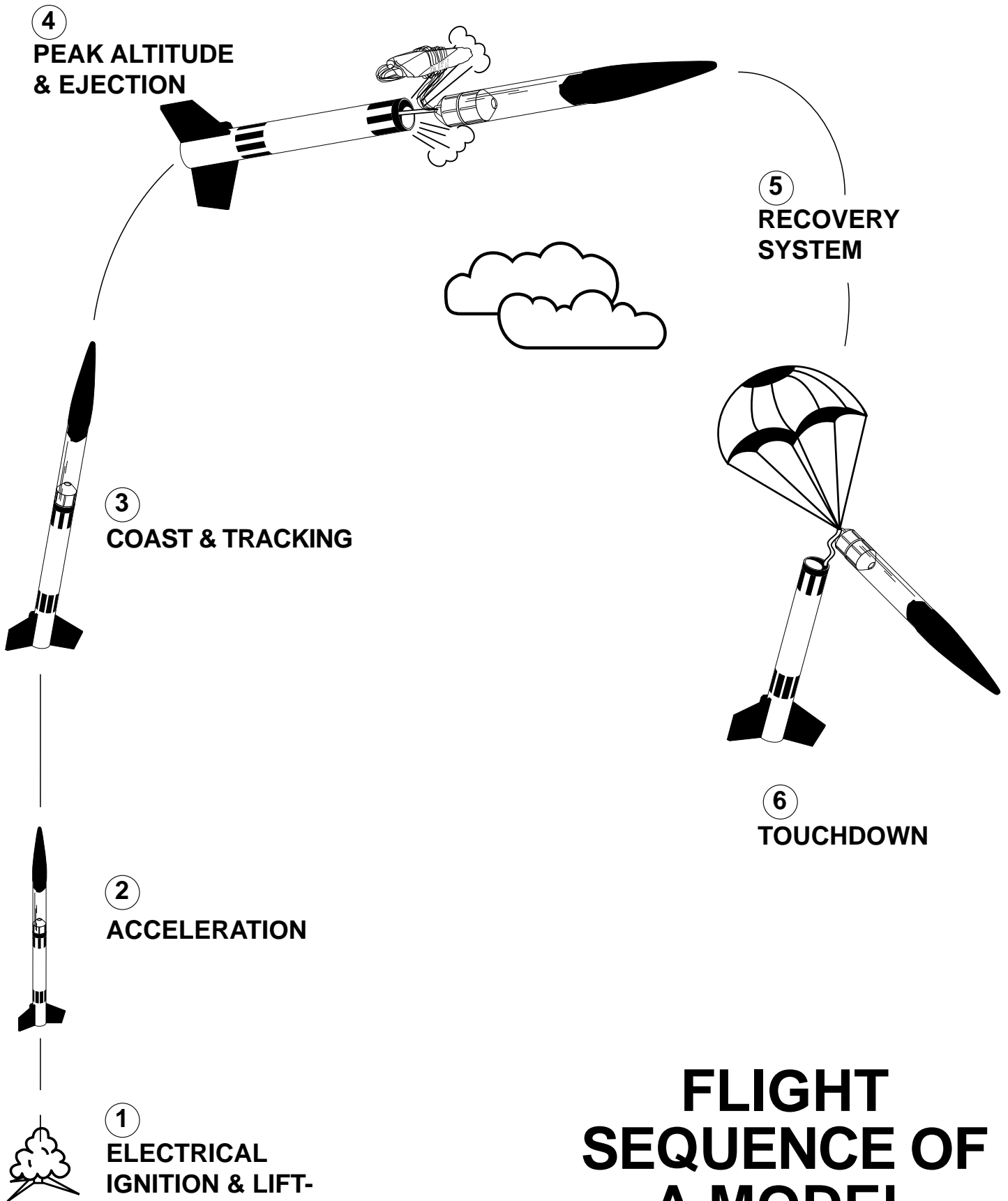

# FLIGHT SEQUENCE OF A MODEL ROCKET

# PICTORIAL OF A TYPICAL MODEL ROCKET LAUNCHER

**ELECTRON  
BEAM®  
CONTROLLER**

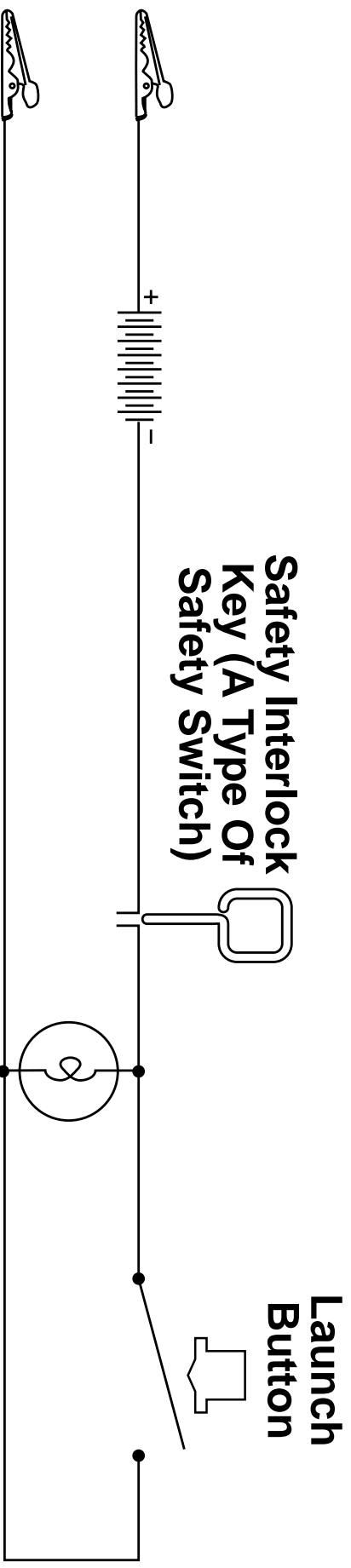
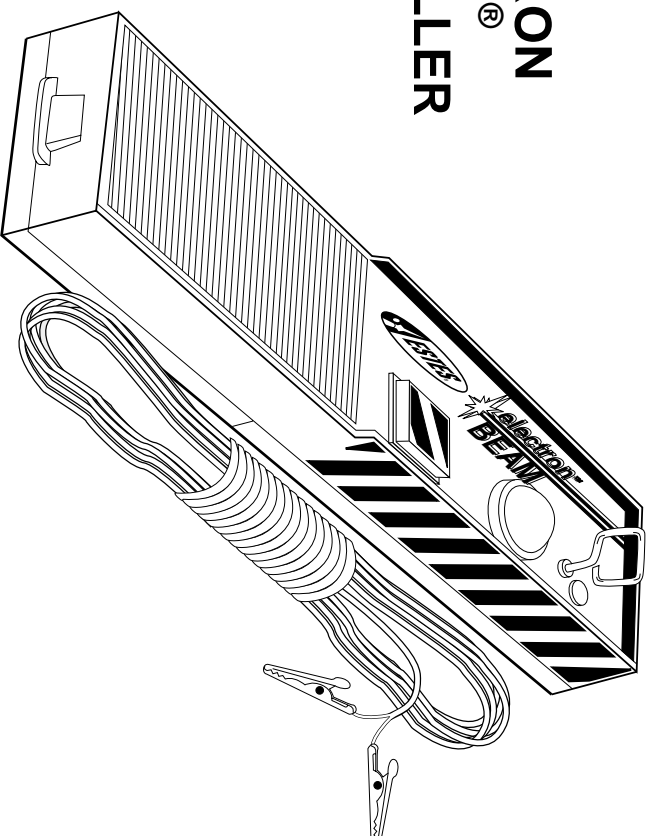

TR8.1

# PARTIAL SCHEMATIC DIAGRAM FOR A TYPICAL MULTIPLE LAUNCHER

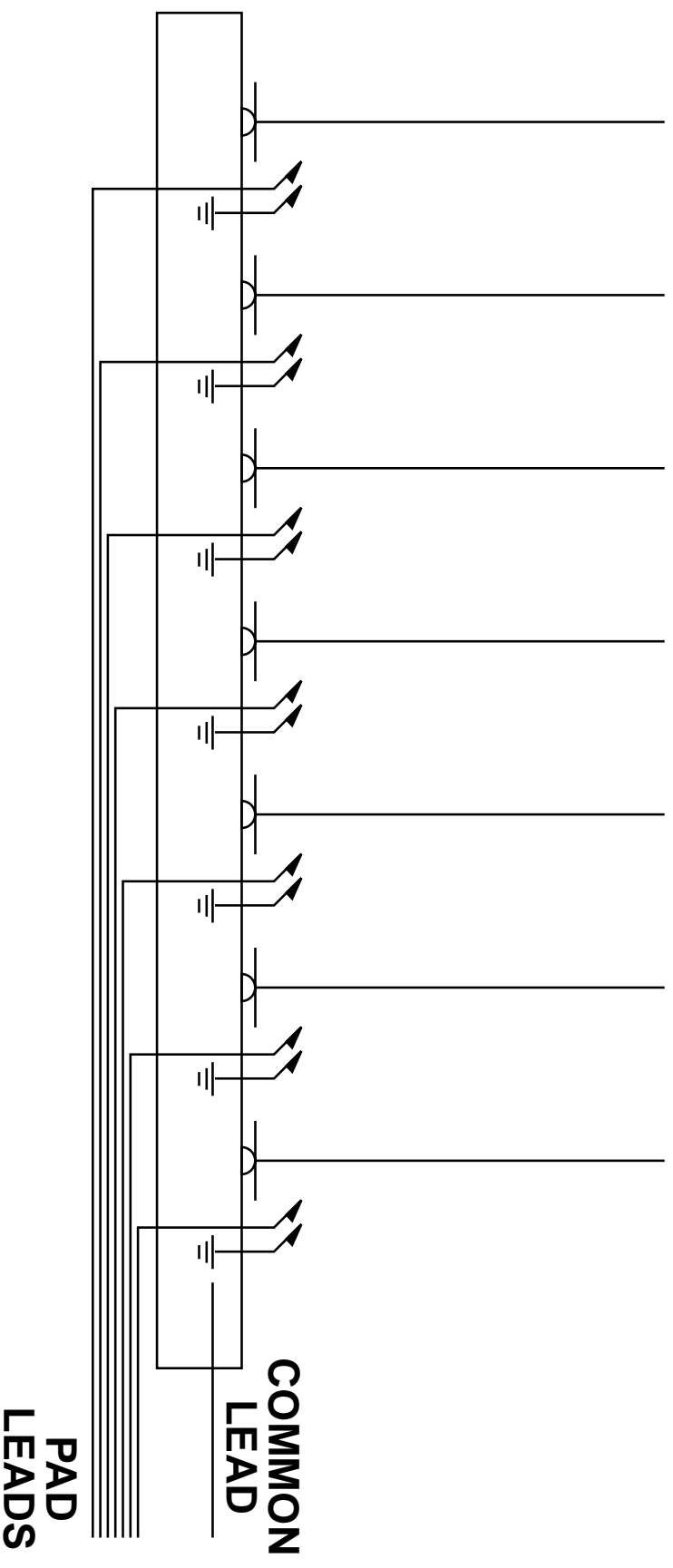

TR8.2A

# TYPICAL MULTIPLE LAUNCHER

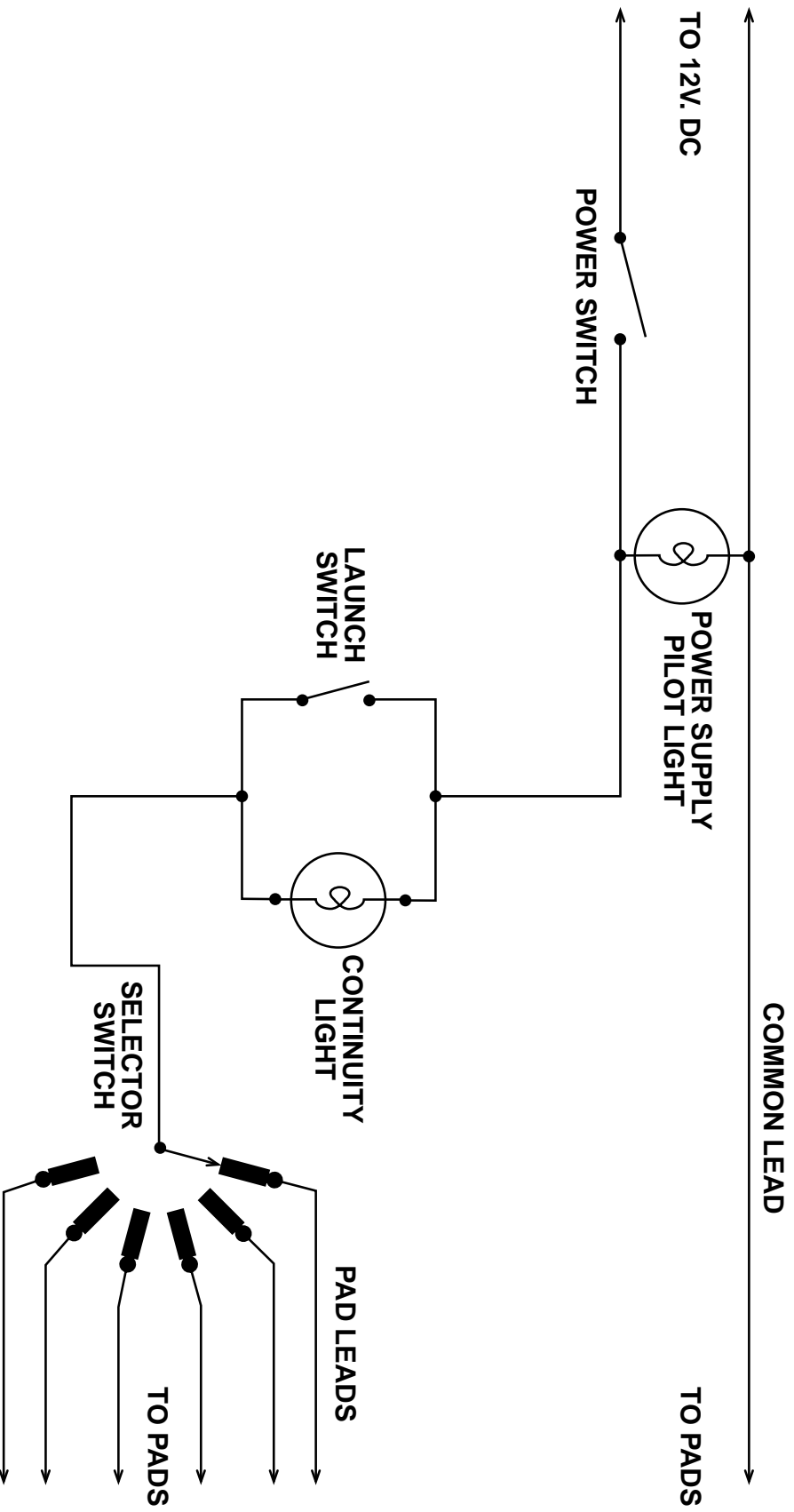

TR8.2B

# SPACE SHUTTLE MISSION PATCHES

(Courtesy of NASA)



STS-1



STS-27



STS-51L



STS-58



STS-45



STS-61A



# SAMPLE SECURITY CREDENTIALS

<b>EHS TEMPORARY AREA AUTHORIZATION ESTES HIGH SCHOOL</b>	
<b>TO BE ESCORTED</b>	
NAME _____	
AGENCY _____	
AUTHORIZED FOR ACCESS TO THE FOLLOWING AREAS	INITIALS
_____	_____
_____	_____
_____	_____
_____	_____
ISSUED BY	DATE

<b>EHS TEMPORARY AREA AUTHORIZATION ESTES HIGH SCHOOL</b>					
NAME _____					
AGENCY _____					
1	2	3	4	5	6
7	8	9	10	11	12
13	14	15	16	17	18
19	20	21	22	23	24
25	26	27	28	29	30
31	32	33	34	35	36
ISSUED BY	DATE				

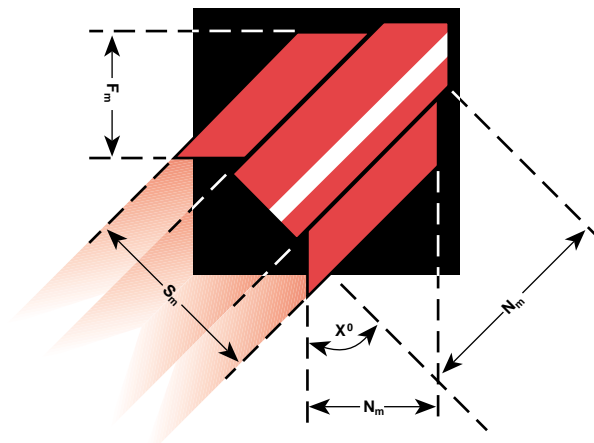

**ESTES**  
**EDUCATOR™**

## APPENDIX



© 1995, 1999 Centuri Corporation.  
All rights reserved.

# Technical Note TN-1 – Model Rocket Engines

This publication or portions may be reproduced by schools for instructional purposes. No other reproduction is permitted without written permission of Estes Industries, Inc. © 1972 by Estes Industries, Inc.,

## Engine Types and Classification

All engines sold by Estes Industries are stamped with a code designation which, when understood, will give the rocketeer important and useful data on the engine's performance-capabilities. Here's how to read this coding: (refer to engine illustration).

## Engine Coding for Quick-N-Easy Identification

- Label color indicates recommended use of the engine.
  - Green: Single stage rockets
  - Purple: Upper stage or single stage, if used in very light rockets
  - Red: Booster and intermediate stages of multi-stage rockets
- Code designation stamped on the engine gives useful and important information on its performance capabilities.
  - This portion indicates total impulse or total power produced by the engine.
  - This portion shows the engine's average thrust in newtons and helps you choose the right engine for your rocket's flight.
  - This number gives you the delay in seconds between burnout and ejection charge. Lets you choose the engine with the delay time you want for any flight.

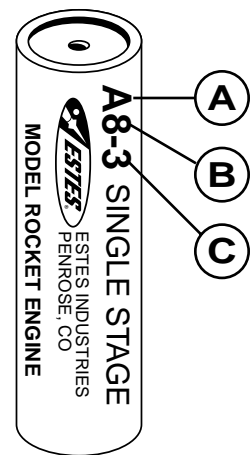

Igniters, igniter plugs and complete instructions are included with Estes engines.

## How high will your model rocket go?

The chart below shows the approximate altitudes that can be achieved with single stage rockets.

Engine Size	Altitude Range (depending on rocket size and weight)	Approximate Altitude in a typical 1 oz. model
1/4A3-2	50' to 250'	100'
1/2A6-2	100' to 400'	190'
A8-3	200' to 650'	450'
B6-4	300' to 1000'	750'
C6-5	350' to 1500'	1000'

(Some high performance models will reach higher altitudes than shown above.)

## Total impulse classification

Code	pound-seconds	newton-seconds
1/4A	—	0.00-0.625
1/2A	0.14-0.28	0.626-1.25
A	0.28-0.56	1.26-2.50
B	0.56-1.12	2.51-5.00
C	1.12-2.24	5.01-10.00
D	2.24-4.49	10.01-20.00

<b>MINI ENGINES</b> (4 per package with igniters & plugs)											
<b>SINGLE STAGE ENGINES (GREEN LABEL)</b>											
Prod. No.	Engine Type	Total Impulse		Time Delay (±15%)	Max. Lift Wt. oz./g	Max. Thrust lb./n	Thrust Duration	Initial Weight		Propellant Weight	
		lb.-sec. <sup>1</sup>	n-sec. <sup>2</sup>					oz.	g	oz.	g
1503	1/2A3-2T	0.28	1.25	2 sec.	2/ 56.6	1.75/ 7.8	0.36 sec.	0.198	5.6	0.062	1.75
1507	A3-4T	0.56	2.50	4 sec.	2/ 56.6	1.75/ 7.8	0.86 sec.	0.268	7.6	0.124	3.50
1511	A10-3T	0.56	2.50	3 sec.	5/141.5	3.00/13.3	0.26 sec.	0.277	7.9	0.133	3.78
<b>UPPER STAGE ENGINES (PURPLE LABEL)</b>											
1504	1/2A3-4T	0.28	1.25	4 sec.	1/ 28.3	1.75/ 7.8	0.363 sec.	0.212	6.0	0.062	1.75
<b>BOOSTER ENGINES (RED LABEL)</b>											
1510	A10-0T	0.56	2.50	none	5/141.5	3.00/13.3	0.26 sec.	0.235	6.7	0.133	3.70

Mini-engines are 4.4 cm (1.75 in.) long and 12.7 mm (0.5 in.) in diameter. Ship Wt. of each package of mini engines is approximately .1 kg (2.5 oz.)

<b>REGULAR ENGINES</b> (3 per package with igniters & plugs)											
<b>SINGLE STAGE ENGINES (GREEN LABEL)</b>											
Prod. No.	Engine Type	Total Impulse		Time Delay (±15%)	Max. Lift Wt. oz./g	Max. Thrust lb./n	Thrust Duration	Initial Weight		Propellant Weight	
		lb.-sec. <sup>1</sup>	n-sec. <sup>2</sup>					oz.	g	oz.	g
1593	1/2A6-2*	0.28	1.25	2 sec.	2.5/ 70.8	2.88/12.8	0.20 sec.	0.53	15.0	0.055	1.56
1598	A8-3	0.56	2.50	3 sec.	4.0/113.2	3.00/13.3	0.32 sec.	0.57	16.2	0.110	3.12
1601	B4-2	1.12	5.00	2 sec.	4.0/113.2	3.00/13.3	1.20 sec.	0.70	19.8	0.294	8.33
1602	B4-4	1.12	5.00	4 sec.	3.5/ 99.1	3.00/13.3	1.20 sec.	0.74	21.0	0.294	8.33
1605	B6-2	1.12	5.00	2 sec.	4.5/127.4	3.00/13.3	0.83 sec.	0.68	19.3	0.220	6.24
1606	B6-4	1.12	5.00	4 sec.	4.0/113.2	3.00/13.3	0.83 sec.	0.71	20.1	0.220	6.24
1617	C5-3*	2.25	10.00	3 sec.	8.0/226.4	5.00/22.2	2.10 sec.	0.90	25.5	0.450	12.70
1613	C6-3	2.25	10.00	3 sec.	4.0/113.2	3.00/13.3	1.70 sec.	0.88	24.9	0.440	12.48
1614	C6-5	2.25	10.00	5 sec.	4.0/113.2	3.00/13.3	1.70 sec.	0.91	25.8	0.440	12.48
<b>UPPER STAGE ENGINES</b> or single stage if used in a very light rocket <b>(PURPLE LABEL)</b>											
1607	B6-6	1.12	5.00	6 sec.	2.0/ 56.6	3.00/13.3	0.83 sec.	0.78	22.1	0.220	6.24
1615	C6-7	2.25	10.00	7 sec.	2.5/ 70.8	3.00/13.3	1.70 sec.	0.95	26.9	0.440	12.48
<b>BOOSTER ENGINES (RED LABEL)</b>											
1608	B6-0	1.12	5.00	none	4.0/113.2	3.00/13.3	0.80 sec.	0.58	16.4	0.220	6.24
1616	C6-0	2.25	10.00	none	4.0/113.2	3.00/13.3	1.68 sec.	0.80	22.7	0.440	12.48

Regular engines are 7 cm (2.75 in.) long and 17.5 mm (0.69 in.) in diameter. Ship Wt. of each package of engines is approximately .1 kg (4 oz.)

\*Series II engines have semi-core-burning grain with large propellant burning area for high initial thrust with short thrust duration.

<b>'D' ENGINES</b> (3 per package with igniters & plugs)											
<b>SINGLE STAGE ENGINES (GREEN LABEL)</b>											
Prod. No.	Engine Type	Total Impulse		Time Delay (±15%)	Max. Lift Wt. oz./g	Max. Thrust lb./n	Thrust Duration	Initial Weight		Propellant Weight	
		lb.-sec. <sup>1</sup>	n-sec. <sup>2</sup>					oz.	g	oz.	g
1666	D12-3	4.48	20.00	3 sec.	14/396.2	6.4/28.5	1.70 sec.	1.49	42.2	0.879	24.93
1667	D12-5	4.48	20.00	5 sec.	10/283.0	6.4/28.5	1.70 sec.	1.52	43.1	0.879	24.93
<b>UPPER STAGE ENGINES (PURPLE LABEL)</b>											
1668	D12-7	4.48	20.00	7 sec.	8/226.4	6.4/28.5	1.70 sec.	1.55	44.0	0.879	24.93
<b>BOOSTER ENGINES (RED LABEL)</b>											
1665	D12-0	4.48	20.00	none	14/396.2	6.4/28.5	1.70 sec.	1.44	40.9	0.879	24.93
<b>PLUGGED ENGINES</b> for use with R/C rocket gliders <b>(BLACK LABEL)</b>											
1669	D11-P	4.48	20.00	none	16/453.1	6.2/27.6	1.82 sec.	1.55	44.0	0.879	24.93

'D' engines are 7 cm (2.75 in.) long and 24 mm (0.945 in.) in diameter. Ship Wt. of each package of 'D' engines is approximately .2 kg (6.5 oz.)

Complete instructions, igniters and igniter plugs are included with each package of Estes model rocket engines.

<sup>1</sup> pound-seconds (Figures shown are optimum)

<sup>2</sup> newton-seconds\* (Figures shown are optimum)

\* A newton is the measurement of force required to move one kilogram of mass one meter per second per second. 1 newton = 0.2248 pounds

**ESTES MODEL ROCKET ENGINES  
HAVE BEEN PROVEN CONSISTENT  
AND RELIABLE IN MORE THAN  
400,000,000 LAUNCHES!**

# Rocket Engine Design

The Series 1 and Mini-engines (T Series) engines are solid propellant type with a dual thrust level design. There is a slight center bore at the very tip of the nozzle end of the propellant grain which serves two purposes. First, it provides for easy ignition. Second, as you will note from thrust curves, this special design produces a high initial thrust which accelerates the rocket to a suitable flying speed quickly. This is because the slight center bore provides a relatively large burning area, resulting in faster consumption of the fuel.

After this initial high thrust, a transition to an end burning grain is made and the thrust drops to a sustaining level (except on low total impulse engines which burn out by this time). Data from wind tunnel tests shows that dual thrust level to be the most efficient design for rocket engines which are to propel light-weight model rockets at subsonic speeds.

The slow-burning delay and tracking charge is ignited at the burnout of the propellant grain. This slow-burning, smoke-producing charge provides no thrust, but permits the rocket to coast upward to its peak altitude. At the burnout of the delay charge a recovery system ejection charge is ignited which pressurizes the forward end of the rocket body tube, activating the recovery system. For further information, see the performance graphs and cutaway drawings.

The B8- engines have a modified center-burning grain. This provides a greater propellant burning area than engines of the same total impulse but which are end-burning. The larger burning area provides a higher initial thrust level but short thrust duration. The B8- engines are especially useful for high acceleration studies, as boosters on heavier rockets and for drag races.

Graphic explanation of a rocket engine's fundamental construction and functions

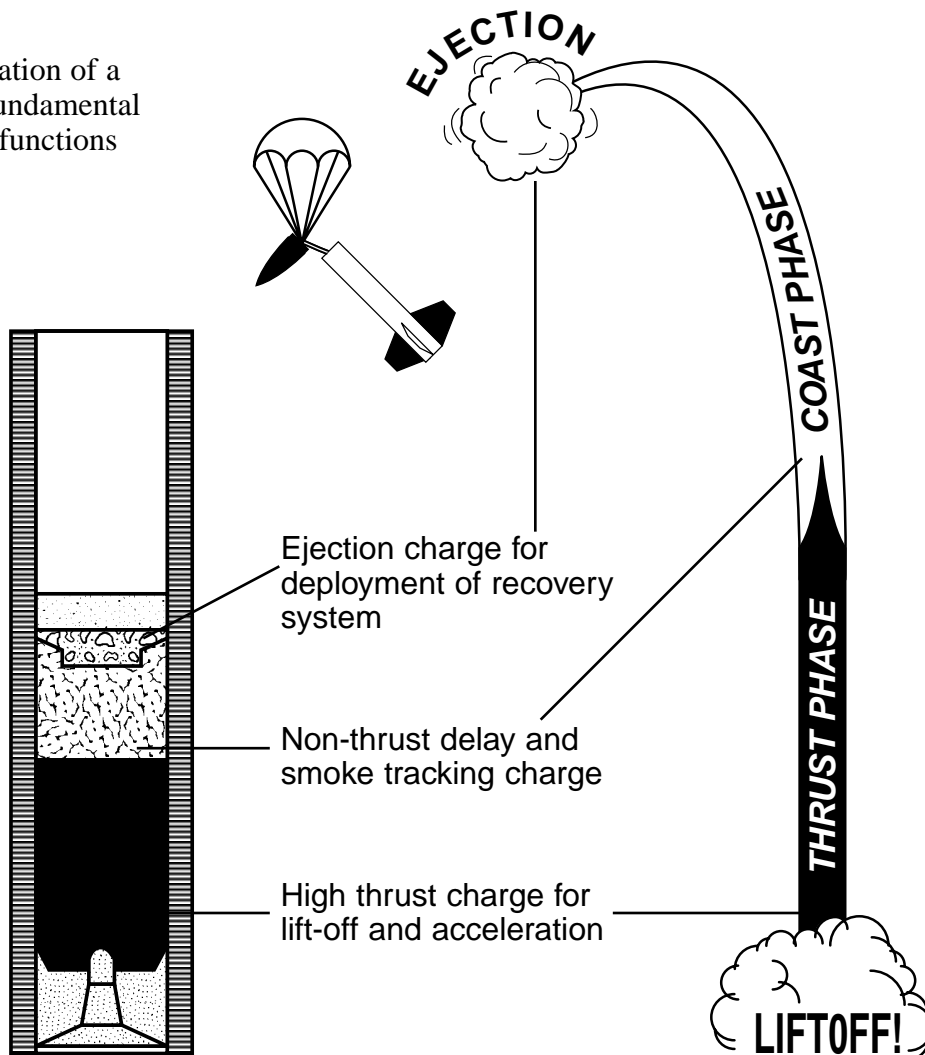

# Comparative Time/Thrust Curves

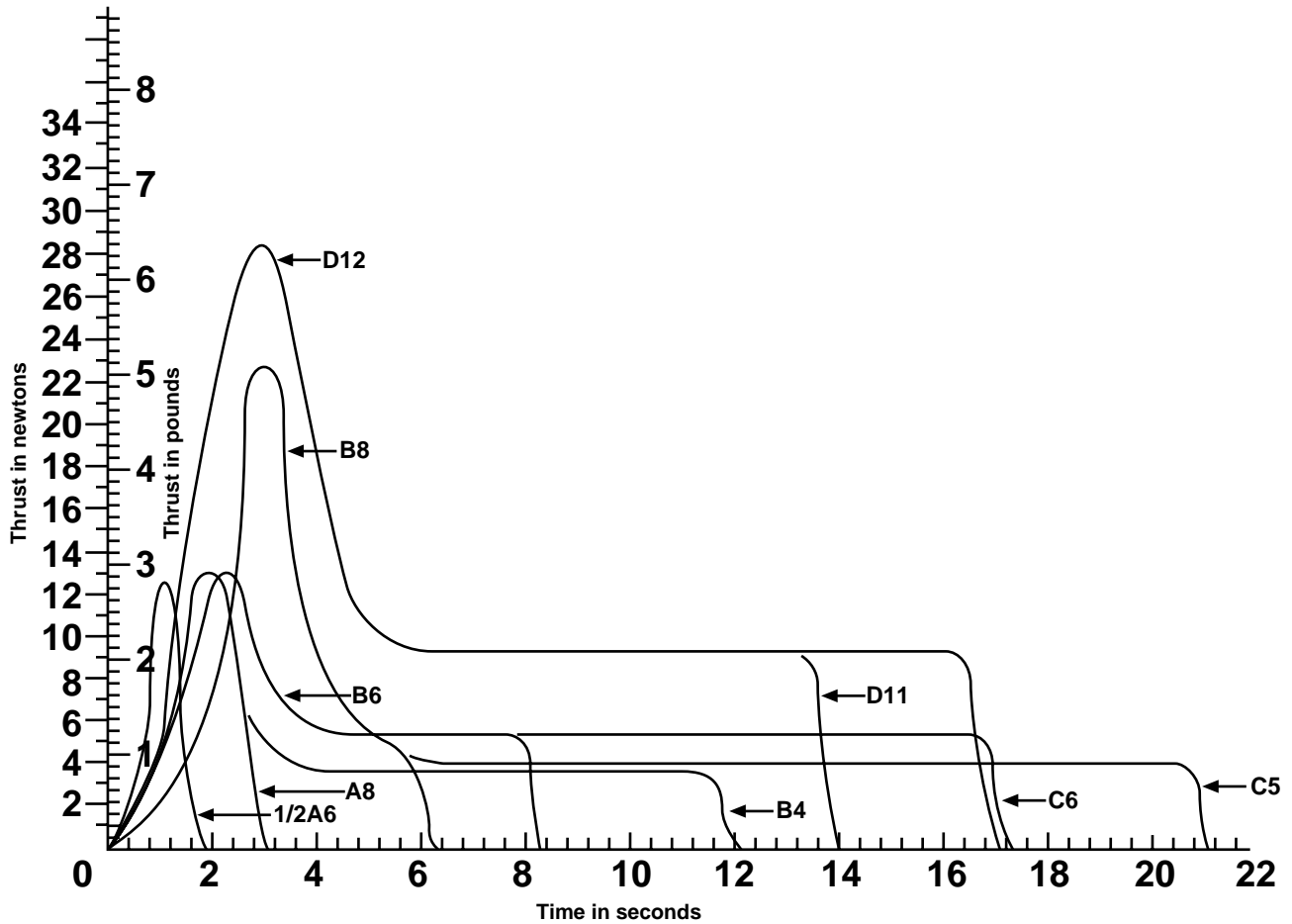
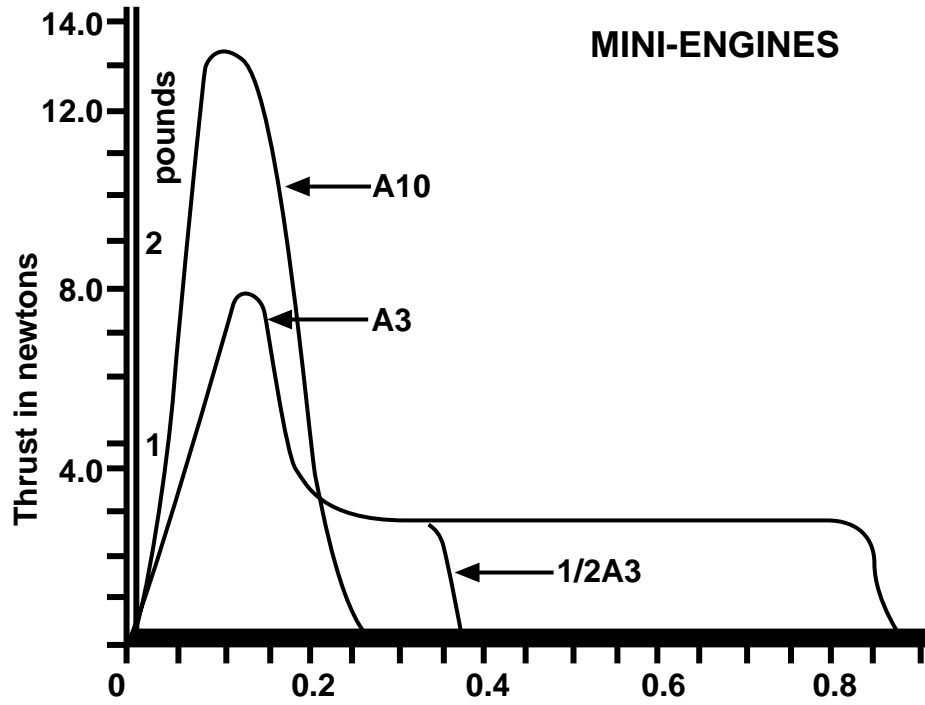

# Typical Time/Thrust Curve of B6-4 Series I

Specific Impulse: 80-83 lb. - sec. per lb.

Exhaust Velocity: 2550-2650 ft./sec.

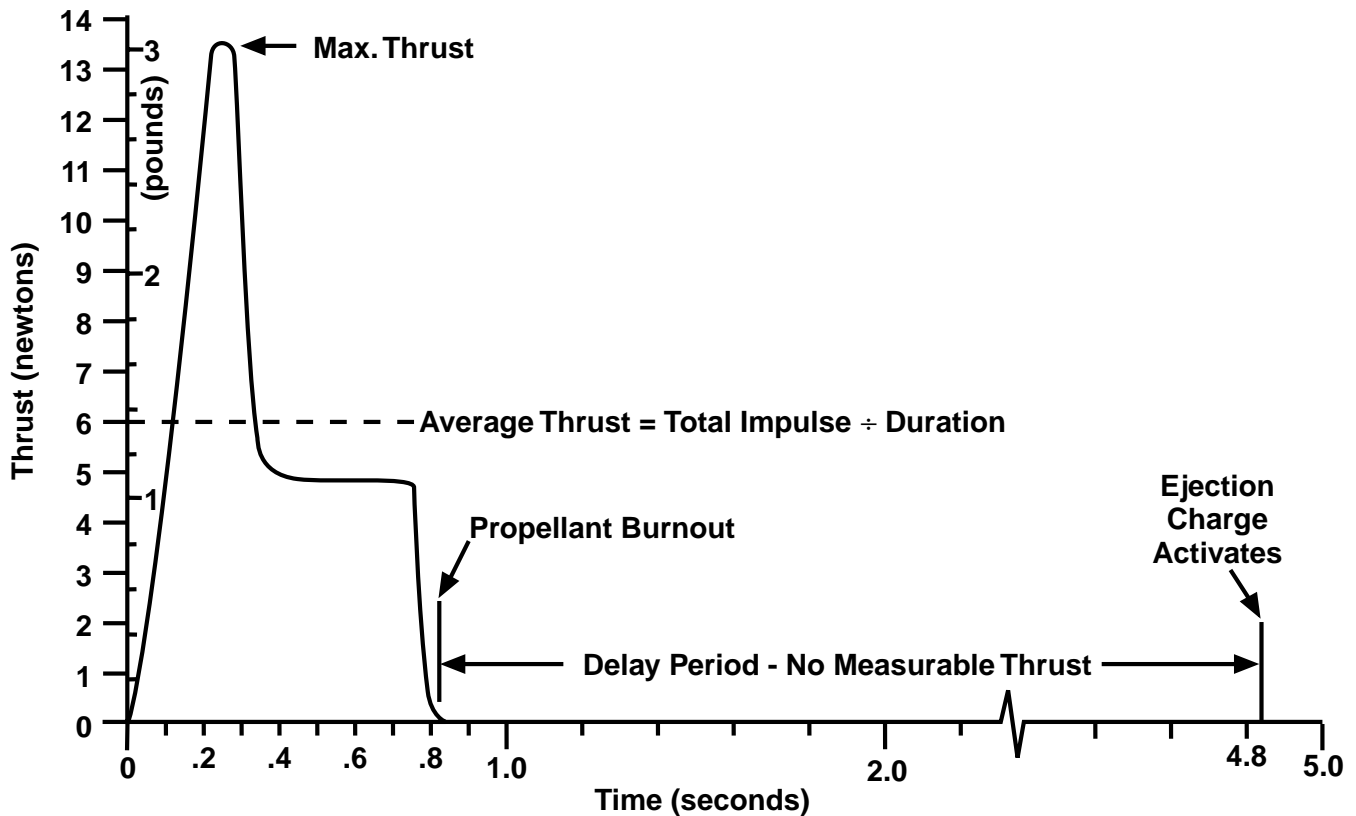
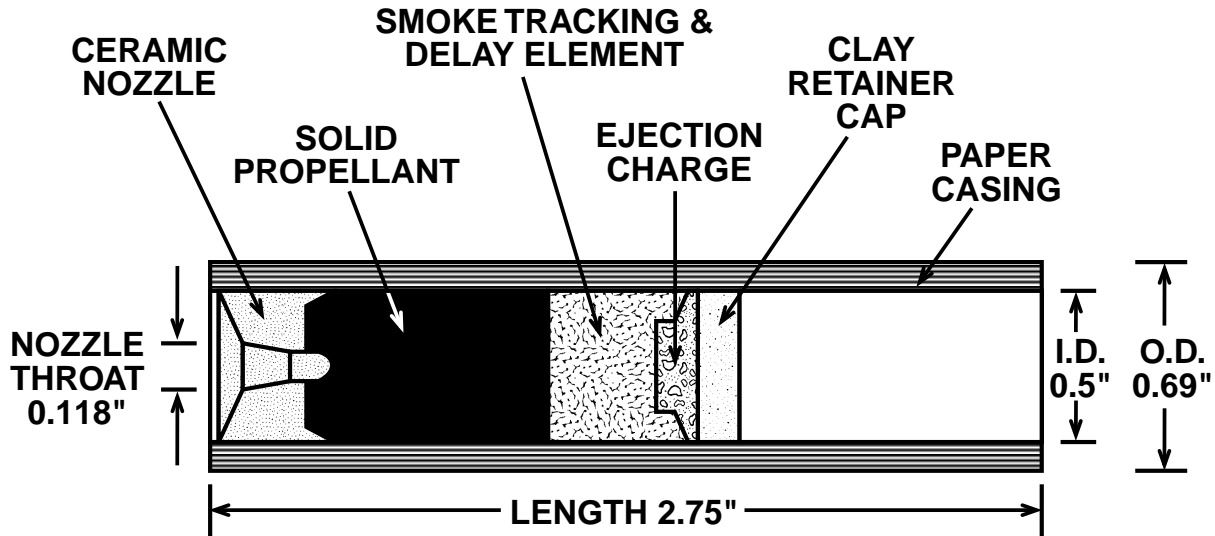

# Typical Time/Thrust Curve of B8-5 Series II

Specific Impulse: 80-83 lb. - sec. per lb.

Exhaust Velocity: 2550-2650 ft./sec.

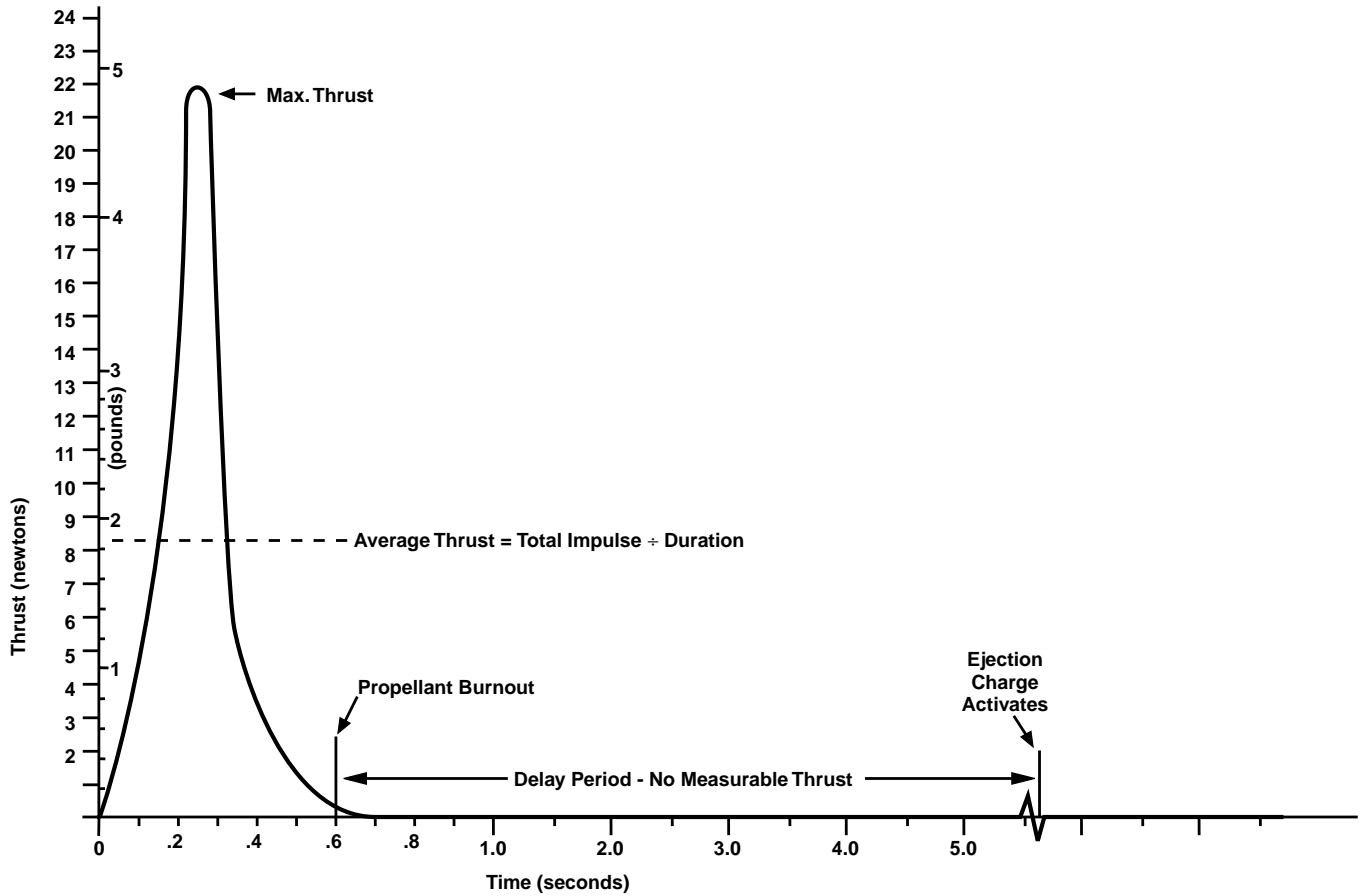
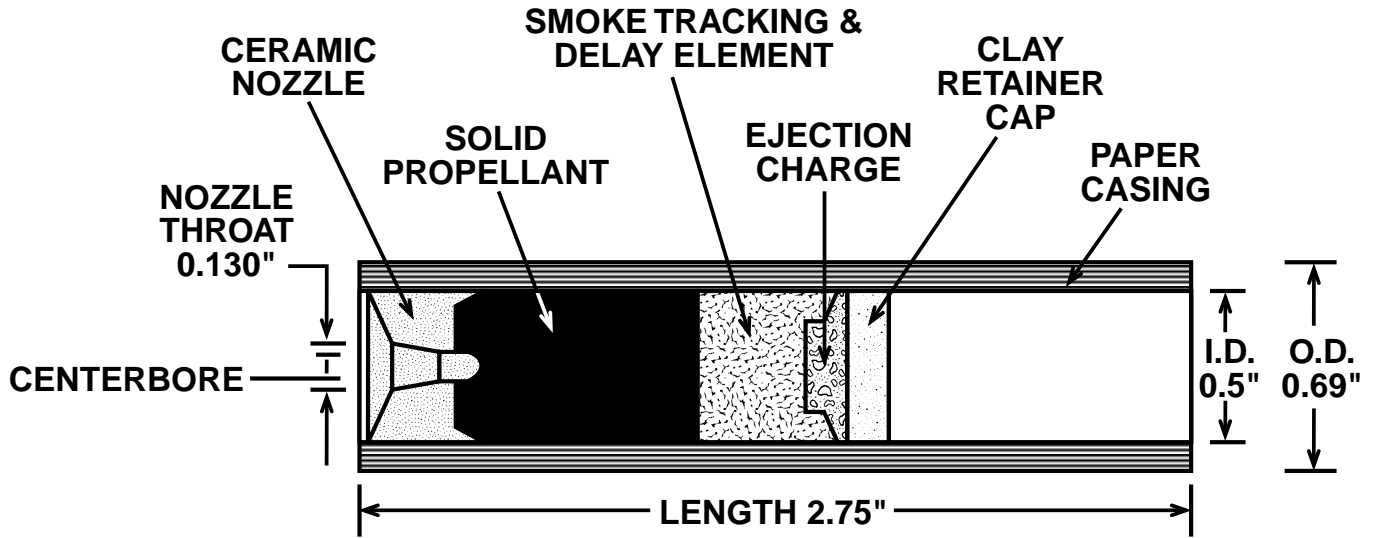



# Technical Note TN-3 – Is That Parachute Too Big?

By Robert L. Cannon

Recovery systems have one function – the safe return of the model rocket. The rocketeer has a choice of several recovery systems, the most popular of which is parachute recovery.

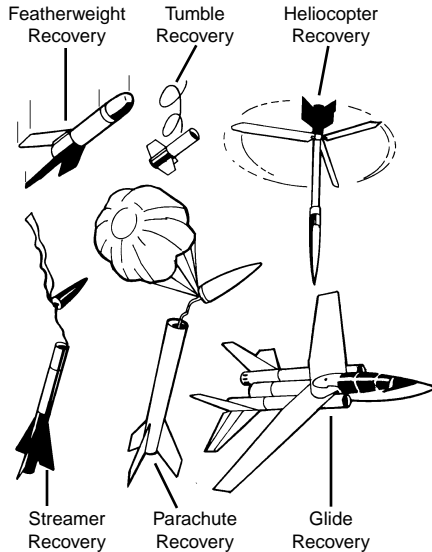

Regardless of the recovery system chosen, it must let the rocket fall back to the ground gently. To accomplish this the rocket must not undergo “free fall”. A lightweight model rocket of balsa and cardboard can fall fairly rapidly. The streamlined shape of the rocket permits it to fall at close to the maximum possible acceleration for a body falling freely through air. This rate of acceleration is 32.2 feet per second per second. This means that an object will be falling 32.2 feet per second faster at the end of each second than it was falling at the start of that second. The actual maximum velocity a freely-falling body can reach is called terminal velocity. This velocity is less than the theoretically possible velocity because the air through which it is falling slows down the rocket, just as it slowed the rocket’s powered flight. This drag slows the rocket’s movements.

Various devices are used to increase the effect of this aerodynamic drag so that the rocket falls very slowly. The greater the drag for a given weight, the slower the rocket falls. Too little drag could let the rocket fall fast enough to be damaged on impact. With too much drag, a breeze may cause your model to drift a great distance downwind before it returns to the ground.

The higher your rocket is at apogee, the longer it will take to return with a parachute of specific size. The bigger the parachute, the longer the rocket will stay in the air. If you consistently launch your rockets to high altitudes or if you live in a windy area, having too much parachute can be a big problem! There are several ways of letting your rockets fall faster yet still be safely recovered by parachute.

One simple way to reduce the drag a parachute creates is to “reef in” the shroud lines. This is done by effectively shortening the shroud lines to keep the parachute from coming fully open. This can be done by “shortening” the shroud lines with masking tape or a piece of string.

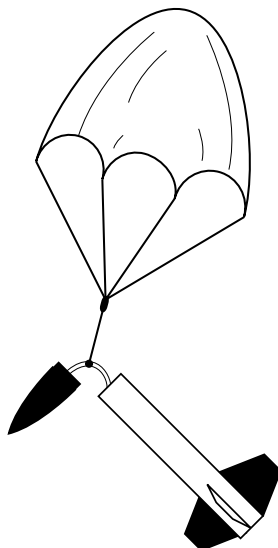

Another method of reducing the drag caused by a parachute is to cut a circular hole out of the center of the “chute”. Experiment to determine the best size of hole for the parachute in the rocket you are using. Start with a small hole and slowly enlarge it until it doesn’t drift far, but slowly enough to be recovered safely. Be careful so that the hole is always round and has no sharp edges. The shock of opening can exert tremendous force on the parachute so any cut or sharp corner can rip under the stress.

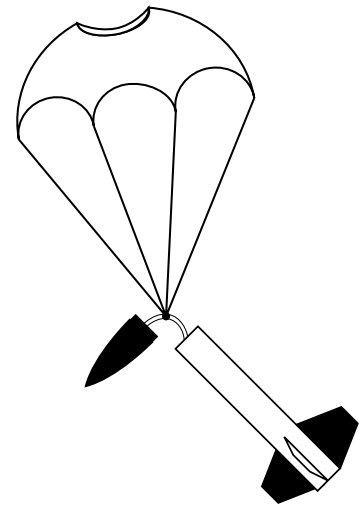

Of course, you can speed the descent of your rocket by selecting a smaller-sized parachute. This is very easy if a snap swivel is attached to each of your parachutes. Pre-test the size of the parachute for safe recovery by hand-tossing the model into the air with the parachute hand-wadded but outside the body tube or by dropping the rocket with the parachute unfurled from a high elevation, such as a second or third floor window.

Streamers can also be used. Test carefully since streamers work best on very light-weight models.



# BIBLIOGRAPHY, REFERENCES AND PLACES TO GET GREAT INFORMATION

Altitude Prediction Charts (TR-10), Estes Industries, Penrose, CO, 1971.

Altitude Tracking (TR-3), The Classic Collection: Model Rocketry, Estes Industries, Penrose, CO, 1988.

Banks, Mickael A.. Advanced Model Rocketry, Kalmbach Books, Waukesha, WI, 1993.

Bilstein, Roger E. Orders of Magnitude: A History of the NACA and NASA, 1915-1990, National Aeronautics and Space Administration, Washington, DC, 1989.

Building a Wind Tunnel (TR-5), The Classic Collection: Model Rocketry, Estes Industries, Penrose, CO, 1988.

Cannon, Robert L. The Fine Art of Payload Launching (TN-4), The Classic Collection: Model Rocketry, Estes Industries, Penrose, CO, 1988.

Cannon, Robert L. Model Rocket Contest Guide, Estes Industries, Penrose, CO, 1990.

Cannon, Robert L. Model Rocket Launch Systems, Estes Industries, Penrose, CO, 1976.

Cannon, Robert L. Is that Parachute too Big? (TN-3), The Classic Collection: Model Rocketry, Estes Industries, Penrose, CO, 1988.

Cannon, Robert L. Projects in Model Rocketry, Estes Industries, Penrose, CO, 1974.

Cannon, Robert L. Newton's Laws of Motion and Model Rocketry, Estes Industries, Penrose, CO, 1979.

Estes Educator News, Volume 19, Number 19, Estes Industries, Penrose, CO, 1993.

Estes, Vernon. Rocket Stability (TR-1), The Classic Collection: Model Rocketry, Estes Industries, Penrose, CO, 1988.

Gregorek, Gerald M. Aerodynamic Drag of Model Rockets (TR-11), Estes Industries, Penrose, CO, 1970.

Kellner, Wayne. Recovery Techniques (TN-6), The Classic Collection: Model Rocketry, Estes Industries, Penrose, CO, 1988.

McDougall, Walter A. ...The Heavens and the Earth: A Political history of the Space Age. Basic Books, New York, 1985.

Model Rocket Engines (TN-1), The Classic Collection: Model Rocketry, Estes Industries, Penrose, CO, 1988.

Nolte, Sylvia. Mathematics and Model Rocketry, Estes Industries, Penrose, CO, 1994.

Nolte, Sylvia. Physics and Model Rocketry, Estes Industries, Penrose, CO, 1992.

Nolte, Sylvia. Science and Model Rocketry, Estes Industries, Penrose, CO, 1992.

Pratt, Douglas. Basics of Model Rocketry, Kalmbach Books, Waukesha, WI, 1993.

Rockets: A Teacher's Guide with Activities in Science, Mathematics, and Technology, National Aeronautics and Space Administration, Washington D.C., 1996.



**Estes Industries**  
**1295 H Street**  
**Penrose, CO 81240**